

ICES WKARMAC REPORT 2010

ICES ADVISORY COMMITTEE

ICES CM 2010/ACOM: 46

(UPDATED VERSION)

Report of the Workshop on Age Reading of Mackerel

1-4 November 2010

Lowestoft, UK



ICES

International Council for
the Exploration of the Sea

CIEM

Conseil International pour
l'Exploration de la Mer

International Council for the Exploration of the Sea Conseil International pour l'Exploration de la Mer

H. C. Andersens Boulevard 44–46
DK-1553 Copenhagen V
Denmark
Telephone (+45) 33 38 67 00
Telefax (+45) 33 93 42 15
www.ices.dk
info@ices.dk

Recommended format for purposes of citation:

ICES. 2010. Report of the Workshop on Age Reading of Mackerel, 1-4 November 2010, Lowestoft, UK. ICES CM 2010/ACOM: 46. 66 pp.

For permission to reproduce material from this publication, please apply to the General Secretary.

The document is a report of an Expert Group under the auspices of the International Council for the Exploration of the Sea and does not necessarily represent the views of the Council.

© 2010 International Council for the Exploration of the Sea

Contents

Executive Summary	1
1 Terms of Reference.....	2
2 Agenda and participation.....	3
3 Review information on age estimations, otolith exchanges, workshops and validation work (ToR a).....	4
3.1 Exchanges and Workshops	4
3.2 Validation work	5
3.3 Conclusions and recommendations	5
4 Resolve interpretation differences between readers and laboratories; most recent exchange and workshop exercise (ToR b)	6
4.1 Most recent exchange	6
4.1.1 Material and methods	6
4.1.2 Results	7
4.1.3 Conclusions.....	8
4.1.4 Tables.....	9
4.2 Workshop exercise.....	15
4.2.1 Material and methods	15
4.2.2 Results	15
4.2.3 Conclusions and evaluation of the exercise	17
4.3 Recommended actions for resolving interpretation differences between readers	18
5 Report on progress of the compilation of biometrics data of mackerel otoliths (ToR c) and their applicability as supplement to age reading (ToR d)	20
5.1 Introduction.....	20
5.2 Methods	20
5.3 Applicability	21
5.4 Conclusions and recommendations	21
6 Compilation of an agreed manual for age estimation of mackerel (part of ToR e)	23
6.1 Introduction.....	23
6.2 Methods and preparation.....	23
Table 6.2.2: Benefits and drawbacks of some of the most commonly used methods of preparation.	25
6.3 Agreed criteria for ageing mackerel.....	26
6.3.1 Viewing the otoliths	26
6.3.2 Age determination criteria.....	27

6.3.3	Other available information	29
6.3.4	Otolith interpretation	29
6.3.5	False or Split Rings	29
6.3.6	Factors affecting annual ring formation	29
7	Collation of a set of agreed age otoliths (part of ToR e)	31
8	Recommendations for further cooperation, exchanges, workshops and other actions in relation to the age estimation of Mackerel (part of ToR e).....	32
8.1	General recommendations	32
8.1.1	Manual.....	32
8.1.2	Standardised reading within laboratories	32
8.1.3	Quality control between labs.....	34
8.1.4	Regular workshops.....	34
9	References	35
	Annex 1: Agenda.....	37
	Annex 2: List of participants.....	38
	Annex 3: Recommendations.....	41
	Annex 4: State of the art of known mackerel biology	43
	Annex 5. WD by Hüsey <i>et al.</i> 2010 ‘The use of otolith surface area in age determination of mackerel’	47
	Annex 6 Results of the post-workshop exchange of mackerel (<i>Scomber scombrus</i>) otolith images 2010	52

Executive Summary

The overall result of the exchange and workshop exercise is that there are significant variations in mackerel age estimates between readers. Low precision, and large relative biases between readers were found, and the older ages (from age 6) were particularly difficult to reach agreement upon.

The workshop achieved quite a lot in terms of ironing out, through discussion and calibration, some of the major problems in ageing otoliths of mackerel. The group reached agreement on the definition of a set of ageing guidelines. These are mentioned in the present report, and the aim is to employ these guidelines to eliminate some of the problems with e.g. interpretation of the otolith edge.

The image analysis exercise clarified that the lack of agreement can be mainly attributed to the perception of the otolith edge, depending on season and area of catch.

Exploring the application of image analysis, the group agreed that applying such tools in both exchanges and workshops dealing with mackerel may prove very valuable. It gives the opportunity to discuss in depth the definition of which age structures to count, and additionally gives a very useful exchange tool for the individual readers to use, both within and between laboratories.

A collection of agreed age otoliths was started at the workshop using the few agreed otoliths from the exchange. The reference collection will be expanded considerably through an exchange of otolith images performed immediately after WKARMAC. Additionally, the collection of agreed age otoliths should not stand alone, but be a part of a larger compilation of data on 'typical' otoliths for the species and area, in which typical distances between age-structures, edge development over season, and general growth curves for mackerel are represented across its area of existence.

1 Terms of Reference

2009/2/ACOM47 The **Workshop on the Age Reading of Mackerel [WKARMAC]** (Chair: Lotte A. Worsøe Clausen*, Denmark) will be established and take place in Lowestoft, England, 1-4 November, 2010, to:

- a) Review information on age estimations, otolith exchanges, workshops and validation work done so far.
- b) Analysis of the results of exchange programme between ageing labs, using a set of otoliths (images) collection partially from tagging material and from previous WK collection with the purpose of inter-calibration age readers involved in Stock assessment.
- c) Report on progress of the compilation of biometrics data of mackerel otoliths.
- d) To revise the age estimation procedures and explore the possibilities to use supplementary information for validating estimated age structures, these include:
 - Otoliths weight distributions
 - Length distribution in surveys and catches.
- e) Address the generic ToRs adopted for workshops on age calibration (see ['PGCCDBS Guidelines for Workshops on Age Calibration'](#))

WKARMAC will report by 29th November, 2010 for attention of ACOM.

SUPPORTING INFORMATION:

Priority:	Essential. Age determination is an essential feature in fish stock assessment to estimate the rates of mortalities and growth. Assessment of mackerel stocks using age structured models has proved useful in establishing a diagnosis on stock status. However, the approach has several limitations and shortcomings such as stock structure, natural mortality and growth. Age data is provided by different countries and are estimated using international ageing criteria which have not been validated. Therefore, an otolith exchange programme and WK should be carried out in order to know the current situation of age estimation of mackerel which has been subject of concern of ICES, and make progress towards a solution.
Scientific justification:	For the purpose of inter-calibration between ageing labs an appropriate exchange programme with a set of otoliths (images) collection partially from tagging material and from previous WKs collection will be carried out for next year. The aim of the workshop is to identify the current ageing problems between readers from both stocks through a reference collection. To identify the state of art of age estimation after validation studies conducted so far.
Resource requirements :	Before starting the exchange programme, the scientific institutions should make a concerted effort to compile the existing tagging material (digital otolith images) that can be used as a reference collection.
Participants:	In view of its relevance to the DCR, and ICES WG, the Workshop try to join international experts on growth, age estimation and scientists involved in assessment in order to progress towards a solution.
Secretariat facilities:	
Financial:	None

Linkages to advisory committee:	ACOM
Linkages to other committees or groups:	WGWIDE and PGCCDBS
Linkages to other organizations cost:	There is a direct link with the EU DCR
Secretariat marginal cost share:	

2 Agenda and participation

The agenda is presented in Annex 1, and list of participants in Annex 2.

3 Review information on age estimations, otolith exchanges, workshops and validation work (ToR a)

The frequency of workshops and exchanges on age reading of mackerel in the past is far from impressive. The first reported workshop on mackerel ageing was held in Lowestoft in 1987 and following that only one workshop has been held (in 1995 in Spain) and one additional exchange in 2002. All previous workshops and exchanges have had an outcome stating the overall agreement to be somewhat low but fair, but skewed towards having a higher agreement on the younger ages. This is not surprising; however, there is certainly room for improvement both in terms of consistency and agreement between readers.

Both workshops discussed and made an effort to standardize age reading methods by preparing a manual and a reference collection of agreed age otoliths.

3.1 Exchanges and Workshops

The first exchange and workshop held in 1986 and 1987 respectively, had as first priority to assess the agreement level on the older mackerel, as the assessment working group on mackerel at the time wanted to review the applied plus-group (11+). The participants read through two collections of otoliths, one consisting of otoliths covering all age groups and one holding particularly older individuals for comparison.

The workshop had access to a small number of known-age otoliths which proved very valuable in ironing out discrepancies in the interpretation of the appearance of the edge (opaque/translucent) and timing of the age-structures. This appeared to be area specific within the same season.

The overall agreement was calculated using a somewhat different method than what has been used in later workshops; however, the agreement percentage was in the better range (0.3 in a range of 0.0 being perfect agreement and 0.83 being total disagreement). Of particular interest was that the agreement on the set of otoliths comprised of older individuals did not differ significantly from the agreement on the 'normal' set of otoliths. The conclusion of the workshop was thus that the age estimation of older individuals was not associated with a higher variation between readers than age reading of younger individuals and the workshop concluded that the plus-group in the assessment could be expanded to be 15+.

The second workshop, held a decade later, in 1995 (ICES 1995) had as objectives to evaluate a preceding exchange (Villamor and Meixide, 1995), discuss and standardize age reading methods by preparing a manual and a reference collection and give advice on which age groups valid age reading could be achieved. The participants worked with extensive material, no less than 6 sets of otoliths were read prior to and during the workshop, differing in various ways concerning the area and age-range of the otolith set.

Similarly to the workshop in 1987, the readers had access to a number of known-age otoliths from a Norwegian tag-release program, and again this set of otoliths proved very valuable in discussions and aided in the creation of age reading criteria for mackerel.

The readers participating in the workshop reached an overall agreement of around 70%, depending upon the sample. The sampling area significantly influenced the degree of agreement and contrary to the findings in the workshop in 1987; the older fish

had a tendency to be underestimated compared to modal age. For the known-age set; the agreement was 76%.

As a conclusion; the age-reading technique was validated up to age 8 as bias was observed in the ages of older fish and the workshop ended up recommending the plus-group for the assessment of mackerel to be 12+. The workshop concluded that an appropriate measure of precision would be 2.00 for 2stdev from the modal and assigned age.

Prior to the WKARMAC 2010, which also was preceded by an extensive exchange of otoliths (see chapter 4 of the present report), a small scale exchange of mackerel otoliths was performed in 2002 in the SAMFISH project (Study Contract 99/009; IMPROVING SAMPLING OF WESTERN AND SOUTHERN EUROPEAN ATLANTIC FISHERIES). The objectives of the exchange were to monitor the precision of age readings, following the protocols established by EFAN (FAIR concerted action PL96/1304,) and to collate a reference database of otolith images from the exchange material. Only 6 institutes participated in the exchange and thus the scale was somewhat smaller than both the previous exchanges and the most recent exchange (ref to chapter 4 of the present report).

The conclusion from the exchange was that the precision drops significantly after age 4, and although two institutes did show an improvement in precision from the previous workshop in 1995, the remaining readers showed little improvement. The project concluded that further exchanges and workshops on mackerel were highly warranted.

3.2 Validation work

The existing material of such work is rather limited, particularly related to the actual yearly age structures of mackerel otoliths.

Daily ring structures have been validated (Mendiola and Álvarez, 2008); and their study gives the potential for validating the first years of growth, making standards (L1, etc) and ruling out double structures in the first years of life. Knowing that the microstructure is daily, it may be possible through analysis of the combined transparency and width of the daily rings on the edge of juveniles over the season to validate the formation of the first and potentially following 2-3 age structures.

The existence of otoliths from the Norwegian Mark-Recapture experiments are potentially the golden stones and could iron out many subjective assumptions related to the age estimation of mackerel from this area (and potentially other areas). It is of utmost importance that the dimensions and availability of such material is clarified and that efforts are made to reach agreement on potential availability for coordinated validation studies.

3.3 Conclusions and recommendations

Thus; the exchanges and workshops seem to improve the precision of the age readings both within and between age readers to some degree, but are still not increasing the accuracy or dramatically increasing the percent agreement between them.

What could help improve this would be direct, measurable ways to age mackerel, decreasing the degree of subjective evaluation of age structures and thus validation of age structures is highly warranted and recommended.

4 Resolve interpretation differences between readers and laboratories; most recent exchange and workshop exercise (ToR b)

4.1 Most recent exchange

The last exchange between European mackerel otolith reading institutes took place in 2002 during the SAMFISH project. Since then, veteran readers have departed and new readers recruited to read otoliths. A mackerel otolith exchange was carried out in March 2008 to ensure a consensus between these new readers.

Under the coordination of Marine Scotland Science, formerly FRS Aberdeen, Scotland, a representative collection of otoliths was prepared. Samples were included from all quarters in the year and all ICES areas relevant to this exchange. This collection was distributed to all 12 countries which supply data for the assessment of North East Atlantic mackerel (13 participating institutes). The exchange started in September 2008 at Aberdeen and ended at DTU Aqua in Denmark in August 2009. Some otolith samples showed deterioration through the course of the exchange. This caused an increase in non-readable otoliths for the countries that received the otolith package towards the end of the exchange.

The estimated ages from each participating institute were returned to the coordinators and analysed by comparing them against the resulting modal age. From this, the percentage agreement, precision coefficient of variation (%CV) and bias were calculated. Participants were divided into readers who provide ages to the assessment (experts) and those that do not (non-experts).

This report describes the analysis made of the final age determinations received by the coordinators by mid-August 2009. These were carried out by 23 readers based in 13 institutes (Table 4.1).

The complete list of participants from October 2008 was: UK – Scotland, UK – England, The Netherlands, Norway, Portugal, Spain (AZTI and IEO), Germany, Denmark, France, Eire, Faroe Islands and Iceland.

4.1.1 Material and methods

The 195 otoliths used in this exchange were sourced from four of the participating institutes. All were from mackerel sampled in 2006, 2007 or 2008 and a breakdown is given in Table 2 by sampling year, month and area.

By calendar quarter, the greatest percentage (38%) of otoliths were from quarter 1, while 13%, 18% and 31% were from quarters 2, 3 and 4, respectively.

All otoliths used in the exchange were mounted according to an agreed protocol on black plastic trays, concave side up, using Eukitt transparent resin to fix the otoliths. However, otoliths from the Spanish institute AZTI became damaged in transit and were rendered unreadable. The AZTI otoliths were re-mounted by the exchange coordinators at FRS, Aberdeen prior to reading and circulation. Unfortunately this re-mounting caused some damage to these otoliths, with a few being broken in the process and so rendered more difficult to age.

4.1.2 Results

The age determinations were input to the "Age Comparison Worksheet" (Eltink *et al.*, 2000).

Readers were divided into two categories:

- 1) Experts: whose age estimations are submitted for stock assessments;
- 2) Non-experts: whose age estimations are not submitted for stock assessments.

Age data were entered into the Age Comparison Worksheet (ACW) from the leftmost column according to years of experience of experts, as the ACW is designed to give more weight to "experts" than to other participating readers. For each otolith read, modal age was used as the basis for agreement of readings, that is, the age determined by the greatest number of experts. If two ages were read by equally high numbers of experts, the first calculated modal age (leftmost) was taken as the final modal age. Ageing results from non-experts were compared individually to the experts' modal age.

Of the 195 otoliths circulated:

- 181 resulted in an age determination being made by all 15 experts.

Of the 14 others:

- 10 were not able to be read by expert 6;
- 8 were not able to be read by expert 2, 5 of which were in common with expert 6;
- 1 was not able to be read by expert 9.

There were only 12 otoliths (6%) with complete agreement on age by all 15 experts. If otoliths with 14 agreed determinations were included, this agreement rose to 15 (8%). Along with the modal age for each otolith, percentage agreement, mean age, and precision (coefficient of variation) were also calculated:

- Percentage agreement = $100 \times (\text{no. of readers agreeing with modal age} / \text{total no. of readers})$ (for each otolith)
- Precision C.V. = $100 \times (\text{standard deviation of age readings} / \text{mean of age readings})$ (for each otolith).

Percentage agreement ranged from 20% to 100%, with an average of 67.6%. Of the 195 otoliths, 69 were read with at least 80% agreement. The otoliths (corresponding to mackerel of lengths 40 and 41 cm) with the smallest percentage agreement (20%) provided the following estimates of age:

40 cm		41 cm	
Age	No. of readers	Age	No. of readers
4	1		
5	1	5	2
6	2	6	2
7	1	7	3
8		8	3
9	2	9	3
10	2	10	2
11	3	(8 modal age)	
12	1		
13	1		
14	1		
(11 modal age)			

The precision coefficient of variation ranged from 0% (corresponding to 100% agreement in readings) to 387% with an average of 23.8%. The four exceptionally high coefficients of 387% arise from one expert's age determination of four otoliths with a modal age of 0. This expert determined three of these otoliths as 1 year old, and one otolith was determined as 4 years old. All other experts were in complete agreement with the modal age of 0 for these otoliths. The effect of excluding these four otoliths from the calculation of precision coefficient of variation was to reduce the average to 16.2%.

4.1.3 Conclusions

There were 12 otoliths (6%) upon which there was complete agreement on age among the 15 experts. These otoliths tended to be amongst the youngest as determined by modal age. Overall, with respect to modal age, the percentage agreement on age determinations was 67.6% and the precision coefficient of variation was 23.8%. Relative bias in age determination by individual experts ranged between -0.59 and +0.45.

The eight non-experts had a more pronounced tendency to underestimate when compared to modal age. Although the eight were described as being inexperienced, some are known to have had training in the reading of mackerel otoliths but have had limited opportunity to hone their skills, whilst others had no experience of reading mackerel otoliths.

The figures which should cause most concern at this point are the range of ages determined against modal age, contained in Table 3. Such large discrepancies between age determinations highlight the need to hold a workshop, so participants can reduce these discrepancies and find a more "common ground" in which to work. Views on the effect of packaging and sending otoliths around a group of thirteen institutes over a period of a year should also be sought as this might have been an issue with this exchange of mackerel otoliths.

4.1.4 Tables

Country	Institute	Number of experienced readers	Number of inexperienced readers
Denmark	DIFRES	1	0
Eire	Marine Institute	1	1
Faroe	FFL	0	2
France	IFREMER	0	2
Germany	vTI	1	0
Iceland	MRI	0	1
Netherlands	IMARES	1	1
Norway	IMR	4	0
Portugal	IPIMAR	1	0
Spain	AZTI	1	0
Spain	IEO	2	0
UK - England	CEFAS	2	0
UK - Scotland	FRS	1	1
All	All	15	8

TABLE 4.1.4.1: Summary of Age Reading Participants Included in Final Analysis

Month and year	Sampling area	Portugal	Spain		UK-Scotland	Total
		IPIMAR	AZTI	IEO	FRS	
Feb. '07	VIIIc East			10		
Feb. '08	IVa				10	
Mar. '06	VIIIb		15			
Mar. '07	IXa	10				
Mar. '07	VIIj				10	
Mar. '08	VIa				20	
Q1 total		10	15	10	40	75
May, '06	VIIIb		10			
May, '07	VIIIc West			10		
Jun. '07	IXa	5				
Q2 total		5	10	10		25
Jul. '07	IXa	15				
Aug. '07	IVb				20	
Q3 total		15			20	35
Oct. '07	IVb				20	
Nov. '07	VIIIc East			10		
Nov. '07	VIIIc West			10		
Nov. '07	VIa				10	
Nov. '07	VIIb				10	
Q4 total				20	40	60
Total		30	25	40	100	195

TABLE 4.1.4.2: Summary of Sourcing of Otoliths Used in the Exchange

Modal age	Number with complete agreement	Possible total based on modal age	Percentage with total agreement	Range of ages determined
0		4		0 - 4
1	2*	15	13	1 - 4
2	9 †	25	36	1 - 5
3	2	21	10	2 - 7
4	1	38	3	2 - 9
5	1	29	3	2 - 9
6		22		2 - 11
7		13		3 - 11
8		16		4 - 15
9		7		4 - 14
11		2		4 - 14
12		2		8 - 19
15		1		7 - 16

* Both determinations made by 14 readers only

† One determination made by 14 readers only

TABLE 4.1.4.3: Mackerel Otoliths with Complete Agreement on Age by 15 Expert Readers

Country	Institute	Reader	Percentage agreement	Coefficient of variation	Relative bias
Denmark	DIFRES	6	44.9	23.0	-0.35
Eire	Marine Institute	13	55.4	13.4	-0.59
Germany	vTI	9	67.5	11.9	-0.39
Netherlands	IMARES	2	69.0	17.4	-0.13
Norway	IMR	1	72.8	14.4	0.39
Norway	IMR	10	68.2	17.6	0.45
Norway	IMR	11	72.3	15.7	0.33
Norway	IMR	12	73.8	11.0	0.26
Portugal	IPIMAR	3	51.3	22.9	0.16
Spain	AZTI	5	72.3	12.1	-0.35
Spain	IEO	4	77.4	11.1	-0.10
Spain	IEO	8	72.3	15.0	0.10
UK - England	CEFAS	7	73.8	13.4	-0.02
UK - England	CEFAS	14	69.7	15.5	-0.13
UK - Scotland	FRS	15	72.3	10.9	0.21

TABLE 4.1.4.4: Performance by 15 Expert Readers in terms of Percentage Agreement, Coefficient of Variation and Relative Bias

Country	Institute	Reader	Rank of percentage agreement	Rank of coefficient of variation	Rank of relative bias	Overall rank
Denmark	DIFRES	6	15	15	11	15
Eire	Marine Institute	13	13	6	15	12
Germany	vTI	9	12	4	12	11
Netherlands	IMARES	2	10	12	5	10
Norway	IMR	1	4	8	13	9
Norway	IMR	10	11	13	14	14
Norway	IMR	11	4	11	9	8
Norway	IMR	12	2	2	8	3
Portugal	IPIMAR	3	14	14	6	12
Spain	AZTI	5	6	5	10	6
Spain	IEO	4	1	3	2	1
Spain	IEO	8	6	9	2	5
UK England	CEFAS	7	2	7	1	2
UK England	CEFAS	14	9	10	4	7
UK Scotland	FRS	15	6	1	7	4

TABLE 4.1.4.5: Ranked Performance by 15 Expert Readers in terms of Percentage Agreement, Co efficient of Variation and Relative Bias

Expert	Difference from modal age																Total different
	-8	-7	-6	-5	-4	-3	-2	-1	0	+1	+2	+3	+4	+5	+6	+7	
6		1		2	3	10	19	29	93	21	13	2	2				102
13	1			1	2	3	10	68	108	2							87
9			1		1		12	45	132	4							63
2				1		5	8	19	137	21	3	1					58
1								3	142	37	5	3	3	1	1		53
10						1		1	133	42	12	4				2	62
11							2	5	142	32	8	3		2	1		53
12								11	144	29	4	4	3				51
3					1	5	14	24	100	20	16	11	3	1			95
5			1			4	5	42	141	2							54
4					1		3	26	151	12	2						44
8						1	1	20	141	20	11	1					54
7					1		3	25	144	17	2	1	1				52
14						2	10	24	136	21	2						59
15							1	14	141	28	7	3		1			54
Total	1	1	2	4	9	31	88	356	1985	308	85	33	12	5	2	2	941

TABLE 4.1.4.6: Frequency of Difference of Determined Age from Modal Age for each Expert Reader.

Quarter	No. of otoliths	Percentage agreement	Coefficient of variation	Relative bias
Jan - Mar	75	73	15	0.02
Apr - Jun	25	59	15	-0.04
Jul - Sep	35 (32)	70 (68)	48 (17)	0.02 (0.01)
Oct - Dec	60 (59)	62 (62)	24 (18)	-0.05 (-0.06)
Overall	195	68	24	-0.01

TABLE 4.1.4.7: Performance by Calendar Quarter in terms of Percentage Agreement, Coefficient of Variation and Relative Bias (figures in brackets are after the exclusion of otoliths with exceptionally high coefficient of variation)

Modal age	Number of otoliths per calendar quarter				Total
	Jan - Mar	Apr - Jun	Jul - Sep	Oct - Dec	
0			3	1	4
1	8		2	5	15
2	6	1	9	9	25
3	10	0	5	6	21
4	17	7	7	7	38
5	11	1	6	11	29
6	9	5	1	7	22
7	5	3	2	3	13
8	5	3		8	16
9	2	3		2	7
10	0	0		0	0
11	0	1		1	2
12	1	1			2
13	0				0
14	0				0
15	1				1
Overall	75	25	35	60	195

TABLE 4.1.4.8: Modal Age of Mackerel by Calendar Quarter Determined by 15 Expert Readers

ICES Area	No. of otoliths	Percentage agreement	Coefficient of variation	Relative bias
IV	50 (47)	60.8 (58.7)	38.2 (15.9)	-0.00 (-0.01)
VI	30 (29)	73.8 (73.1)	30.2 (17.9)	0.02 (0.02)
VII	20	65.9	12.4	-0.17
VIII	65	71.1	16.5	0.02
IX	30	66.7	17.1	-0.01

TABLE 4.1.4.9: Performance by ICES area in terms of Percentage Agreement, Coefficient of Variation and Relative Bias (figures in brackets are after the exclusion of otoliths with exceptionally high coefficient of variation). Only Expert Readers included.

Modal age	ICES sub-area					Total
	IV	VI	VII	VIII	IX	
0	3	1				4
1	4	5		6		15
2	6	4	4	6	5	25
3	6	3	2	5	5	21
4	7	5	3	15	8	38
5	6	1	2	15	5	29
6	4	4	5	5	4	22
7	3	5	0	4	1	13
8	7	2	1	6	0	16
9	3		1	2	1	7
10	0		0	0	0	0
11	1		0	1	0	2
12			1		1	2
13			0			0
14			0			0
15			1			1
Overall	50	30	20	65	30	195

TABLE 4.1.4.10: Modal Age of Mackerel by ICES sub-area by 15 Expert Readers

Country	Institute	Reader	Percentage agreement with experts
Eire	Marine Institute	17	64
Faroe	FFL	19	36
Faroe	FFL	21	42
France	IFREMER	22	42
France	IFREMER	23	40
Iceland	MRI	18	51
Netherlands	IMARES	20	54
UK - Scotland	FRS	16	67

TABLE 4.1.4.11: Percentage agreement of each inexperienced reader with Modal Age derived from Expert Readers only.

Reader	Difference from modal age													Total different	
	-9	-8	-7	-6	-5	-4	-3	-2	-1	0	+1	+2	+3		+4
17				1	1		6	14	38	124	10		1		71
19			1	2	2	4	15	24	21	70	49	7			125
21		1		1	2	3	14	15	26	84	47	2			111
22	1		1		3	5	19	16	65	82	3				113
23	1		1		3	6	22	18	63	80	1				115
18			1	1	1	2	13	17	55	104	1				91
20		2	1		1	4	12	15	25	108	23	4			87
16							1	2	26	130	28	4	2	2	65
Total	2	3	5	5	13	24	102	121	319	782	162	17	3	2	778

TABLE 4.1.4.12: Frequency of Difference of Determined Age from Modal Age for eight Non-expert Readers.

Institute	Order of receiving otoliths (out of 13)	Reader	No. of unreadable otoliths
IFREMER	4th	23	2
vTI	6th	9	1
FFL	10th	21	4
IMARES	11th	2	8
IMARES	11th	20	6
MRI	12th	18	10
DIFRES	13th	6	10

TABLE 4.1.4.13: Summary of readers and institutes for which one or more otolith was unreadable.

Otolith number	No. of readers failing to determine age	Otolith number	No. of readers failing to determine age
16	2	153	1
21	1	156	5
22	1	160	4
29	1	161	1
58	1	162	2
59	1	163	4
60	1	164	5
96	3	165	5
105	1	167	1
117	1		

TABLE 4.1.4.14. List of otoliths which at least one reader found unreadable.

4.2 Workshop exercise

An image based otolith reading exercise was performed before and during the workshop.

The purpose of the exercise was to:

- Assess the level of agreement between readers and labs
- Analyse differences in age reading interpretation of otolith spatial patterns
- Explore the usage of metric measurements of otolith structures as a solution to minimize divergence in age estimation
- Assess the effect of WKARMAC
- Test out image-based reading and OMAP as a new tool for aging workshops

4.2.1 Material and methods

100 otoliths from spawning mackerel (maturity stage 6), sampled by IMARES from commercial catches and egg surveys in 2007 and 2008 in ICES sub area IV and VII, were photographed by DTU-AQUA.

The readers aged the otoliths by marking winter rings on the digital images viewed in OMAP v.1.3 (Jansen, 2010 871 /id). Images were presented with relevant data on biology and sampling. The user then electronically marked their interpretation of each winter ring on the image. The number and position of WRs were automatically stored in a database. After all readers had completed the exercise, figures and tables with relevant statistics were generated in OMAP.

Part I of the reading exercise was performed by 6 readers before the workshop; this was followed up by 17 readers in part II, late in the workshop.

4.2.2 Results

The level of agreement by age in part I and II is depicted on Figure 4.2.1 and Figure 4.2.2 and summarized in Table 4.2.1. There was a marked decrease in agreement between age 4 and 7. The overall agreement was low. The immediate effect of WKARMAC was low (2%), but could only be measured on the 6 readers that had completed both parts of the exercise. If only experienced readers were taken into consideration, the average percent agreement was 28% with a CV of 22%. It must be considered, though, that the exercise was held at day 2 in the workshop and we suggest that the effect of the WKARMAC is evaluated based on the results of the post-workshop exchange (see section 7).

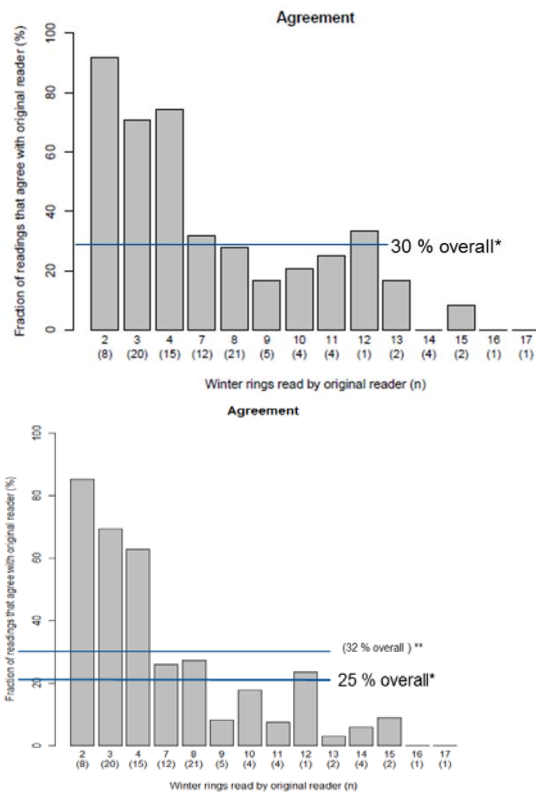

Figure 4.2.1: Level of agreement by age in part I (left) and II (right). Note that there were no otoliths of 5 and 6 WR. * Overall Agreement was calculated as a weighted mean, with the weight of 1/n, where n was the number of otoliths of the given age. This was to give each age equal weight. ** Calculated for only the 6 readers from exercise I.

Age (winter rings)	Part I	Part II	Part II (readers from I)
2-4	79 %	72 %	79 %
7	32 %	26 %	36 %
8-9	22 %	18 %	24 %
10-11	23 %	12 %	19 %
12+	5 %	4 %	9 %

Table 4.2.1: Level of agreement by age-groupings in part I and II. Note that there were no otoliths of 5 and 6 WR. Agreement was calculated as a weighted mean, with the weight of 1/n, where n was the number of otoliths of the given age. This was to give each age equal weight.

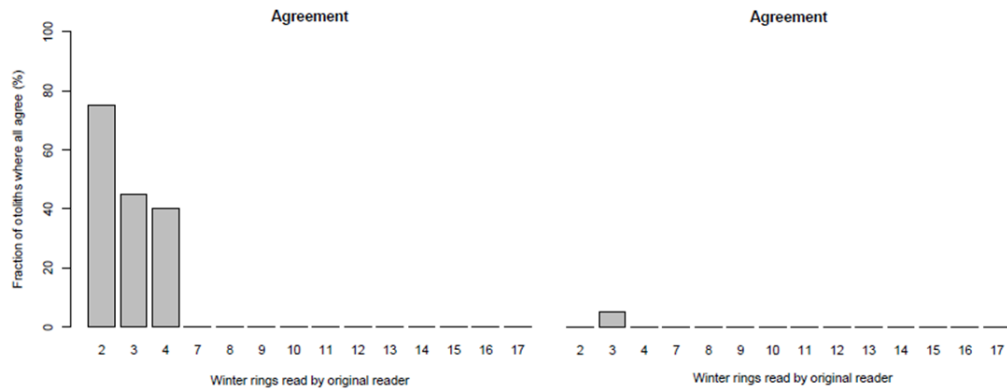

Figure 4.2.2: Level of full agreement by age in part I (left) and II (right).

The variation between readers was very high. Mean number of marked winter rings in the test set varied from 4.1 to 7.1. See Figure 4.2.3.

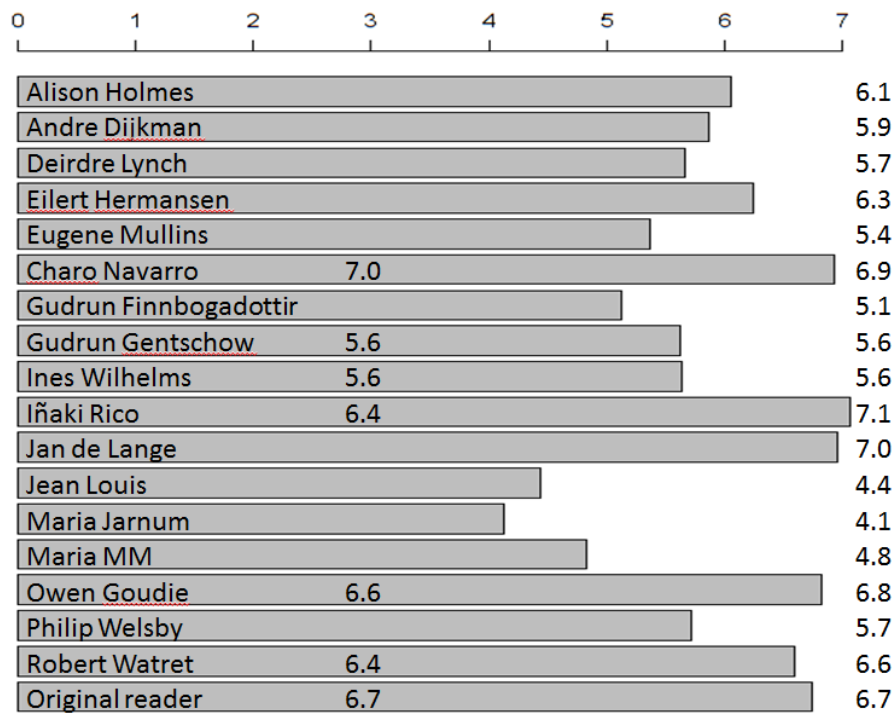

Figure 4.2.3: Mean reader specific differences from part I (middle) and II (right) column.

4.2.3 Conclusions and evaluation of the exercise

The overall level of agreement (25%) was substantially lower than the achieved level in the exchange study (68%). This may be due to several factors, the most important being that this exercise did not take into account neither experience level, nor continuity of the participants re mackerel age estimation. Only subsets of the participants in the exercise were also part of the exchange study in 2008-2009; other readers were trainees with a very limited experience in estimating age for mackerel. If only the experienced readers were to taken into account when judging the results, the overall agreement was 28% with a CV of 22%; thus somewhat higher. However, as the

WKARMAC is the beginning of a renewed crew of mackerel age readers; we chose to include all readers in the results from the exercise.

Secondly, the rather low percent agreement was without doubt a result of poor image quality and the unfamiliarity by the majority of the readers to age mackerel otoliths exclusively using images and not at least a combination of the 'live' otolith and an image. To have a more thorough evaluation of the agreement between the readers in this particular exercise, it would have been optimal to combine the two ways of reading the otoliths and compare the results. However, this was not possible at the time due to both time constraints and the availability of the actual otoliths. Still, the WK found this exercise worthwhile, even though some readers prefer to read otoliths under the microscope, it was concluded that when image quality is good, then otoliths are easy to read from images. The participants acknowledged the strengths and usefulness of this approach during an exchange or at a workshop instead of the more cumbersome traditional exchange of otoliths.

Further conclusions from the study applied to the OMAP software package: (1) A 'preservation' of the annotations would have been preferred. This would enable the readers to return to a previous picture and view the annotations performed on the picture. This could facilitate a re-evaluation of the annotations before submitting the data. (2) A useful feature would be to be able to make two sets of marking on each otolith, where differences were observed in the number of rings on the rostrum and post-rostrum. (3) A lot of age readers looked at the length of the fish before looking at the associated image, this might be detrimental as it can influence the reader's age estimation. French experiments have shown that not knowing the fish's length improves ageing, for difficult otoliths. The length in these cases should not be shown before the user has finished annotating the image. The masking of length is especially important during training of new readers.

4.3 Recommended actions for resolving interpretation differences between readers

There were 12 otoliths (6%) upon which there was complete agreement on age among the 15 experts. These otoliths tended to be amongst the youngest as determined by modal age. Overall, with respect to modal age, the percentage agreement on age determinations was 67.6% and the precision coefficient of variation was 23.8%. Relative bias in age determination by individual experts ranged between -0.59 and +0.45.

The eight non-experts had a more pronounced tendency to underestimate when compared to modal age. Although the eight were described as being inexperienced, some are known to have had training in the reading of mackerel otoliths but have had limited opportunity to hone their skills, whilst others had no experience of reading mackerel otoliths.

The figures which should cause most concern at this point are the range of ages determined against modal age, contained in Table 3. Such large discrepancies between age determinations highlight the need to hold a workshop, so participants can reduce these discrepancies and find a more "common ground" in which to work. Views on the effect of packaging and sending otoliths around a group of thirteen institutes over a period of a year should also be sought as this might have been an issue with this exchange of mackerel otoliths.

The WKARMAC achieved Agreed Age up to age 6 through discussions and actual readings in plenary of selected otoliths. A major task lies ahead to achieve higher agreements on older individuals. First and foremost, validation studies are needed

and highly warranted. The WG WIDE was made aware of the age dependent variation of the age estimations and are encouraged to look further into a possibility of incorporating the increased variance around the problematic age groups in assessment, e.g. by suggesting studies dealing with this issue.

The recent changes in growth patterns, timing of spawning, and the extensive migration of mackerel, all give rise to both seasonal and spatial differences/changes in otolith morphology. This does give differences in the edge appearance within season between areas and also gives rise to disagreements in interpretation. The aforementioned validation studies of these structures are vital for ironing out such differences in perception of the translucent/opaque zones in the mackerel otolith structure.

The group put much effort into reaching agreement on a definition of ageing protocol/guidelines (Chapter 6 to the present report) and the aim is to employ these guidelines to eliminate some of the problems with e.g. interpretation of the otolith edge. The group strongly recommends that all ageing laboratories processing mackerel should include the guidelines developed during the workshop in their ageing manuals. All participants in the workshop agreed to follow the defined guidelines in the present report for the decided upcoming exchange of images to facilitate an evaluation of the guidelines.

5 Report on progress of the compilation of biometrics data of mackerel otoliths (ToR c) and their applicability as supplement to age reading (ToR d)

5.1 Introduction

In assessment context, the result of age determination exercises is to determine catch proportions at age. The goal of the age determination is thus not individual ages but rather proportions of each age class at the population level. A method estimating these proportions on the basis of routine samples therefore appears desirable as this makes it possible to use either otolith biometrics, fish lengths or a combination hereof as ways to achieve proportions at age using easily reproducible and non-subjective measurements of these traits.

Most approaches developed to achieve this suffer from asymptotic bias - i.e. bias does not tend to zero at large sample sizes. The four types of bias found in all early methods are:

- i) Discriminant bias: Associated with specific types of 'cutting rule' in splitting overlapping distributions
- ii) Smoothing bias: Occur when variation in proportion at age is ignored, leading to 'smoothing' of age-classes.
- iii) Heteroscedastic bias: Occur when variation in variance by age are ignored
- iv) Calibration bias: Occur when proportions at age in the calibration sample are different from those in the population.

During the WKARMAC a number of alternatives to reach proportions at age were discussed, particularly whether the methods could decrease the variance around the age estimates for the more difficult part of the population (e.g. older fish).

5.2 Methods

A prerequisite for any method giving age proportions from biometric data are known-age material covering the full span of ages and stocks and thus as such, none of the method discussed here have been performed on mackerel with such a certainty that they are valuable as an alternative to the current age estimation method. However, a number of them do hold the potential for decreasing the variance around the age proportions forming the base for assessment of mackerel.

Length distributions from surveys and catches.

Length distributions using commercial or scientific survey catches by length to different times may be applied to estimate the recruitment, stock numbers at length and age and the fishing mortality during the period covered (Figure 5.2.1). The idea behind the method is to try to identify the cohorts or generations of fish by following the peaks over time as indicated by the solid lines. The method assumes that the growth of the fish can be estimated simultaneously with stock size and mortality. Such length distributions may aid in reducing the variance in the age proportions if applied in unison with the age estimations (see section 5.4).

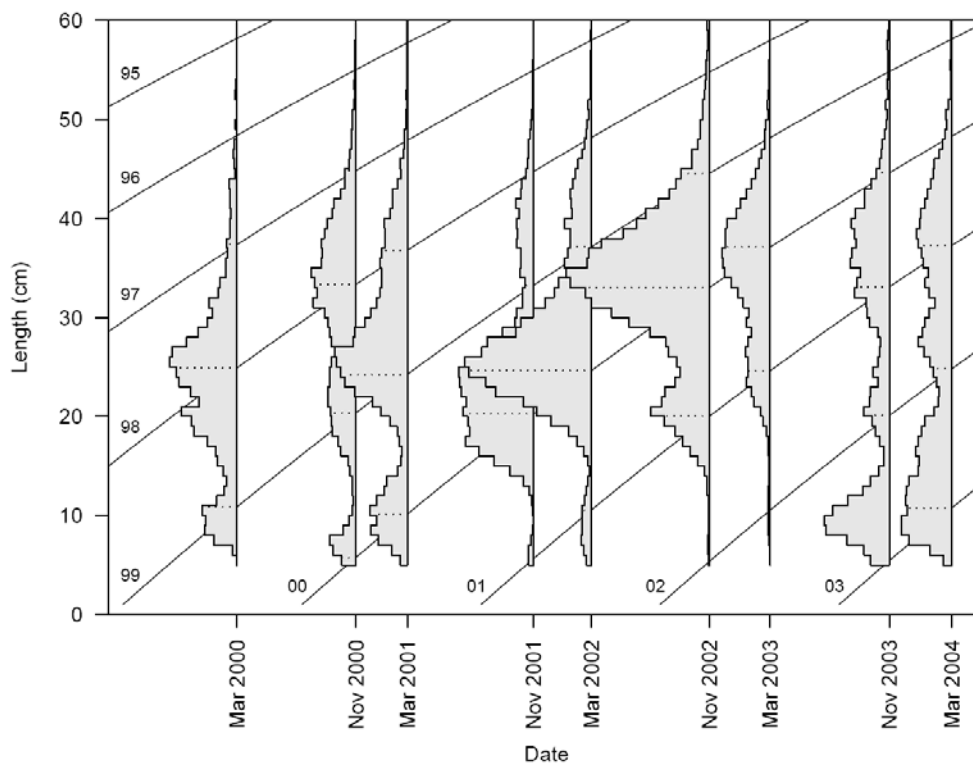

Figure 5.2.1: Length distributions of North Sea cod from the IBTS surveys over a period of 9 years (Kristensen *et al.*, 2006).

Otolith biometrics

The otolith area of mackerel otoliths has been examined as a potential indicator of age. The method applied is the so-called “Length-Mediated Mixture Analysis” (LMMA). This method has been developed by (Francis *et al.*, 2005) and provides unbiased estimates. It is based on known-age Faroese cod and aims at estimating the age distribution in a population, rather than individual ages. Annex 3 to this report is a working document presenting this analysis (Hüssy *et al.*, 2010, WD to the WKARMAC 2010; Annex 5 to the present report).

5.3 Applicability

Using length-distributions from surveys and catches may be used as supporting information when judging the validity of the age estimations, however this still remains to be analysed based on known-age samples.

Otolith biometrics like area are not particularly helpful for younger ages; the LMMA analysis could hold some information for the older age-classes, though, however again; this needs to be validated using a known-age production sample.

5.4 Conclusions and recommendations

Factors such as fish length, otolith weight, otolith area, etc may potentially be used statistically to reduce the noise around the estimations of age proportions if the distributions of these are used for post-processing of the age distributions achieved by otolith readings (A. Nielsen, pers.comm). Potential outliers and skewness of the age proportions may be rectified through such a process, however, a known-age relation between these features and the actual otolith appearance is vital and without such material the risk of bias and erroneous conclusions high.

Alternatively, the variance around the proportions at age could be included in the assessment of mackerel following the hypothetical model in Figure 5.2.2. These models are yet to be developed, however, it is necessary to define for each stock what variance can be accepted around SSB and Fbar by simulation studies (A.Nielsen, pers.comm.).

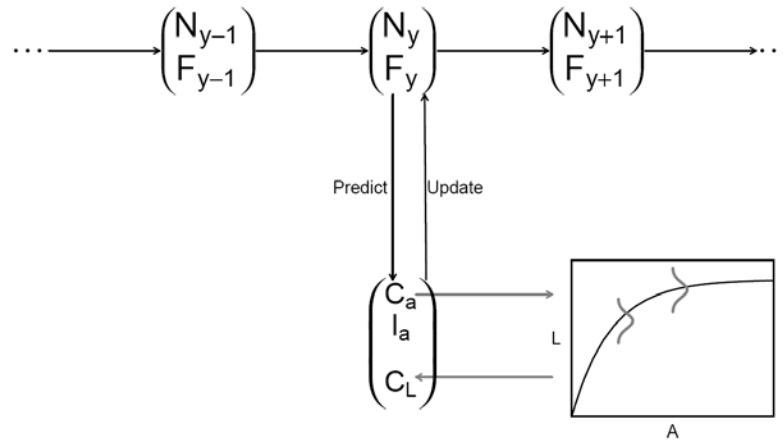

Figure 5.2.2: Applying information of the variance around the age-estimates directly in assessment. C_a : Catch at age; l_a : Length at age; C_L : Catch at length; N_x : Stock numbers (e.g. SSB) at year x ; F_x : Fishing mortality (e.g. Fbar) at year x . Source: A. Nielsen, DTU Aqua, Denmark.

Such analysis of acceptable variance around the estimated proportions at age for mackerel was concluded to be of the utmost importance and the WKARMAC strongly recommends efforts put into this work.

6 Compilation of an agreed manual for age estimation of mackerel (part of ToR e)

6.1 Introduction

This section consists of two main parts, a methodology section describing the various approaches to storing, mounting and viewing the mackerel otoliths by all participating laboratories, and secondly an agreed set of ageing criteria made by the WKARMAC which is an update of all previously used ageing criteria, bridging across differences in perception between readers. The more recent changes in mackerel behaviour in terms of timing of spawning and migration patterns thus call for additional validations of otolith structures, however, the manual can be applied as of now bearing these changes in mind.

6.2 Methods and preparation

Various methods of preparation of otolith samples are used by mackerel otolith reading institutes. Details on each of these are listed in table 6.2.1.

Firstly, the otoliths are extracted from the fish. Mackerel otoliths are removed by making a horizontal cut to the head above the eye from the posterior end of the operculum to the snout. Then a second lateral cut on the head's dorsal side at right angles to the first cut so as to remove that piece of the flesh. This exposes the otic capsule and then both otoliths are removed from the grooves they lie in. For this, straight tipped watch-makers forceps should be used. Care should be taken to ensure the otoliths are kept whole as these structures are very fragile. Alternatively one horizontal cut in the mackerel head can be made in the shape of an 'M' which expose the otoliths.

All institutes have procedures for cleaning the otoliths immediately after extraction. This is required to remove any blood or membrane attached to the otolith. If these are not removed they can dry and create difficulties when the otoliths are read.

An aspect of otolith preparation common to all institutes is the collection and initial storage. Otoliths are collected and put into wells on black plastic trays. It is important the trays are black in order to maximise the contrast between the background and the structures.

The subsequent preparation methodology prior to ageing varies between institutes.

This can be broadly divided into two categories, those that fix the otoliths to the slides and those that keep them loose.

For the fixed method transparent resin is used to cover the otoliths. This has the effect of creating a permanent refractive index surrounding the otolith once the resin has hardened.

Alternately, otoliths can be read loose in the wells. For this a transparent liquid of appropriate refractive index, most commonly ethanol, is added to the wells.

Both of these methods have benefits and drawbacks, which are listed in table 6.2.2.

It is recommended by the majority of institutes that the otoliths are viewed with a binocular microscope, using bright reflected light, preferably from a fibre optic light source, with a magnification of between 15x and 40x depending on the size of the otoliths, (Anon, 1995).

Institute	Cleaning process	Preparation	Medium	Coverslip	Pairs of otoliths per slide	Read with image analysis
England (CEFAS)	In hot water	Fixed	Clear Resin	Yes	25	No
Scotland (MSS)	In water	Loose	Ethanol	N/A	60	No
Ireland (MI)	In water	Fixed	Clear Resin	No	25	No
Spain (IEO)	In water	Fixed	Clear Resin	Yes	10	No
Spain (AZTI)	In water	Fixed	Clear Resin	No	25	No
Netherlands (IMARES)	In alcohol	Fixed	Clear Resin	No	25	No
Denmark (DTU Aqua)	In alcohol	Loose	Ethanol	N/A	25	No
Norway (IMR)	In water	Fixed	Clear Resin	No	25	No
Germany (vTI)	In mild soap solution	Fixed	Clear Resin	Yes	200	No
Portugal (IPIMAR)	In water	Fixed	Clear Resin	No	10	No
Iceland (MRI)	In water	Loose	Ethanol	No	10	No
France (IFREMER)	In alcohol	Loose	Water	N/A	60	Yes
Russia (PINRO)	In water	Loose	Glycerine	N/A	10	No

Table 6.2.1: Summary of Mackerel otolith preparation techniques used.

Mounting method	Benefits	Drawbacks
Resin only	<p>Otoliths are securely fixed</p> <p>Storage is easy following ageing</p> <p>Growth rings can appear very clear</p>	<p>Otoliths cannot be manipulated under the microscope</p> <p>Resin can deteriorate and otoliths become impossible to read i.e.: "frosting" or "cracking"</p> <p>Insufficient resin causes difficulty in reading due to light "scatter"</p> <p>A fume cupboard must be used when using resin due to health risks</p> <p>Time consuming task</p> <p>Otoliths cannot be used for any other process eg: microchemistry, microstructure</p>
Resin with coverslip	<p>Otoliths are securely fixed</p> <p>Otoliths are permanently protected</p> <p>Resin does not deteriorate</p> <p>Storage is easy following ageing</p>	<p>Otoliths cannot be manipulated under the microscope</p> <p>A fume cupboard must be used when using resin due to health risks</p> <p>Time consuming task</p> <p>Otoliths cannot be used for any other process eg: microchemistry, microstructure</p>
Loose in Ethanol	<p>Otoliths can be manipulated under microscope</p> <p>Very time efficient, many otoliths can be read in one day</p> <p>Otoliths can be used for other purposes eg: microchemistry, microstructure</p>	<p>Otoliths can be lost or damaged easily during the process</p> <p>Storage of otoliths can be an issue</p> <p>Health and safety issues with flammable medium</p>

Table 6.2.2: Benefits and drawbacks of some of the most commonly used methods of preparation.

6.3 Agreed criteria for ageing mackerel

6.3.1 Viewing the otoliths

There are two ways of reading mackerel otoliths. The most commonly used is using a binocular microscope, with a reflected light source and a magnification of between x15 and x40, depending on the age of the mackerel. Alternatively the age can be estimated reading digital images (section 6.3.1.1)

6.3.1.1 Age estimation applying digital images

Reading digital images and reading directly onto the images using an image analysis system is an alternative to reading the otoliths under a binocular microscope. Applying this method, the preservation of both reference materials (digitised images of otoliths) and the interpretations of the age structures (annotations done by the reader) can benefit.

It must be borne in mind that a digitised image does not hold the same 'information' for the human eye and the computer. The reader would obviously prefer the best possible image mirroring what is seen in the microscope (i.e. showing all structures of the otolith) whereas the computer just records an image as a matrix of numbers. The latter does allow a wide span of post processing, e.g. improving image quality, extracting structures, making measurements, etc.

Holding all otoliths in an image database first and foremost preserves all collected material as the pictures do not deteriorate like biological material (scales, otoliths), thus all information shown in the pictures are kept for good. The images facilitate a number of things:

- Re-estimation of the age (repeatability of the reader)
- Sharing otoliths with other readers
- Storing information about the readings (traceability)
- Quantitative measurements (growth curves, back calculation, statistical processing, etc)
- Potential improvements of the original image to make the structures more visible

The quality of the digital image obviously has to be as good as possible, thus attention should be paid to light setting, magnification, etc. It is highly recommended that the quality of both the microscope (in particular the objective) and the camera used is as good as possible. The pixel capacity and the light sensitivity of the camera are of particular importance.

Making sure the image is of the highest quality implies a number of things:

- Good preparation of the sample (each species has its own specific method)
- Special attention should be paid to the background and the light, the goal is to have a strong contrast between the opaque and translucent zones (avoid overexposed images)
- The digitised image must be as close as possible to the image you have under the microscope
- The images have to be calibrated (using micrometer as a reference) with the maximum of precision
- The image database should be connected with a database holding all the biological data of the fish

When making age estimations directly on the digitised image, the age structures should be marked applying simple image analysis software. This facilitates a number of post-processing measures, as e.g. achieving average distances between rings, comparison of the growth curve of a specific otolith with the overall growth curve for the otoliths of a particular sample/quarter/etc. It also makes back-calculation of length and additional statistical analysis possible. It must be recognised however, that most of this can only be reliably achieved on images of whole otoliths and not on sectioned otoliths.

The system, by which otoliths are read directly from digitised images and not using a microscope, is fully implemented at IFREMER, France. Here the otolith reader estimates the age of an individual twice, annotates the age structures on the image and checks the entire sample for outliers after finishing the reading exercise. The length of the individual fish is unknown to the reader while doing the age estimation. This information is used as a post-process check using the age-length keys produced for each sample. This technique has been tested by the French institutes where readings performed with 'live' otoliths under a microscope were compared with readings performed directly on digitised images. The percentage of agreement for all species was more than 98%, testing on less complicated otoliths as plaice. However, if trained properly and having a suitable set-up in terms of camera, etc, this technique may be as solid as the more traditional age reading process.

Other institutes have not adopted this system as the increased time taken to photograph all otoliths in a routine ageing program is prohibitive and the results have been highly variable when tested. The percentage agreement stated by IFREMER between images and otolith reading has not been replicated across all species in other labs, even for multiple readings using the same method. Indeed, when using images alone for exchanges, nothing like this level of agreement has been achieved for any stock. It has to be concluded that digitised images are very useful for reference collections and exchanges, but their use for routine ageing programs but their use for routine ageing programs demands a certain degree of training of the readers.

6.3.2 Age determination criteria

It is essential that all otoliths readers are aware of the age determination criteria that should be applied before age determination is attempted (Anon., 1994). The age determination criteria for mackerel are as follows:

- 1) The date of birth is assumed to be 1st January and the fish is assigned to a year class on this basis. Therefore, the date of capture of the sample should always be available.
- 2) One opaque zone and one translucent (hyaline) zone constitutes one year of growth (annulus).
- 3) The timing of the formation of the opaque zone on the edge of the otolith is heavily dependent on the area from which the sample was taken. When allocating the fish to a year class therefore, the area of capture should also be known.
- 4) The summer increment (opaque zone) should be continuous around the otolith (the "ring" should be visible in at least two areas)
- 5) The relative widths of each ring should progressively be smaller as the otolith grows. Although conditions affecting the life history of the fish can create unexpected relative width proportions between annuli.

- 6) For mackerel caught in the 1st and 2nd quarter of the year, all winter rings and the translucent (hyaline) edge are counted. The translucent (hyaline) edge is always counted as one winter ring, even if nothing or very little is visible. Sometimes in young fish from ICES div. VIIIc-IXa, the new ring may not be counted as it depends on how much opaque growth is present (Figure 6.3.2). Thus, the area of capture is very important in this quarter. The decision to include the margin or not should be based on area (up to April and May). For otoliths caught from 1st January to 30th June the reader should count all translucent (hyaline) rings and for those otoliths caught from 1st July to 31st December the reader should assume that the last hyaline ring is not fully formed and therefore not count it. However, if this last ring is thick, then it is probably from last year. It has been noted that a narrow opaque zone is seen at the edge of some otoliths and may be due to a change in the summer growth pattern. The translucent (hyaline) zone that appears before this opaque zone should be counted. A study on the otolith edge is recommended to clarify this.

First semester of the year

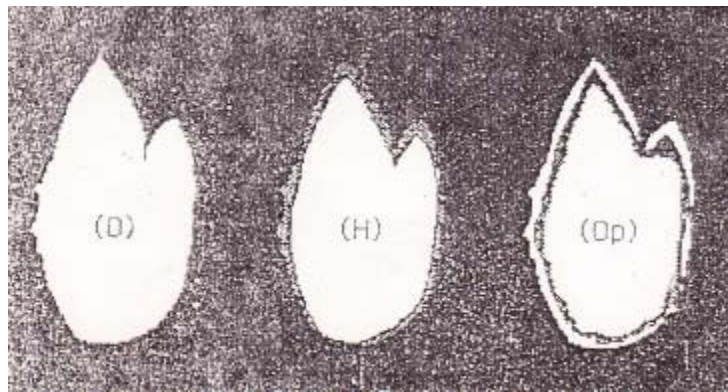

Opaque

Hyaline

New opaque

1 year

Figure 6.3.2: Different kind of 1 year-old mackerel otoliths that are found during the first semester of the year. Azti-IEO. (Paulino Lucio, pers. comm.)

- 7) The edge of the otoliths. The timing of the opaque ring formation on the edge of the otolith differs considerably from one area to the other. It is useful to collect information regarding which months the opaque edge and the translucent (hyaline) edge on the otolith is laid down for each area and age of the fish. For example, the opaque ring formation is earlier in young fish and more southern areas. This information should help otolith readers with the interpretation of the edge of the otolith.
- 8) It is a recommendation of this Workshop to register the confidence level the reader has in their otolith reading, reflecting the quality of the data. Most readers should use a scale of 3 levels of quality:
- Rings can be counted with certainty: 1
 - Rings can be counted, but with difficulty and some doubt: 2

- Rings cannot be counted, the otolith is unreadable: 3

However, Cefas have to use a 4 level key: G (Good), M (Moderate), P (Poor) and 99 (Unreadable). This is because this system is detailed in their accreditation under ISO 17025 and therefore cannot be changed. For the purposes of mapping the 4 level key to the 3 level key, M and P are analogous to level 2.

6.3.3 Other available information

Other information may be available about the fish including length and maturity. There is a school of thought that believes that length information may influence the decision of the reader when assigning an age. While this may be true, any experienced otolith reader will know the approximate length of the fish purely from the features of the otolith. It could be an advantage to have the length available when reading samples of otoliths that are mounted together in large numbers. It is often possible to identify whether otoliths have been mixed up during sampling or preparation.

6.3.4 Otolith interpretation

It is always preferable to have the pair of whole otoliths available when trying to interpret the ring structure. Mackerel otoliths can vary in appearance and therefore it is important to remember that there is no one "correct" position where to count rings. Ideally, the translucent (hyaline) rings should be counted and usually the preferred areas include the rostrums and the posterior regions. As many locations as possible on the otoliths should be examined where the ring structure is clear and the annual rings are visible. This usually involves counting at the rostrum and the posterior region until the reader is satisfied that consistent interpretation has been achieved. However, it is sometimes possible that other areas of the otolith are readable, e.g. the anti-rostrum, and interpretation of appropriate parts of the otolith should be considered, especially if one of the otoliths is broken, missing or crystalline.

Conflicting ages may be achieved if several parts of the otoliths are examined (usually in older fish). If this happens, the oldest age is probably the correct one, as examination of tagged fish otoliths of known minimum age has demonstrated that the highest age is more consistent with the information on the history of fish (Anon., 1987a and section 6.2). Therefore, as a general rule, if in doubt about the interpretation of the rings, assign the fish to the highest age. However, this does not mean that false or split rings should be counted.

6.3.5 False or Split Rings

It is always difficult to define the appearance of false or split rings on otoliths for any species. Usually these are properly identified only after much experience has been gained for a particular species. False or split rings are usually considered to be those rings that are not as well defined as annual rings. The reason for the deposition of false or split rings is not certain, but they might be caused by aberrant temperature, feeding or spawning conditions, stress or disease.

6.3.6 Factors affecting annual ring formation

6.3.6.1 Formation of the first winter ring

Mackerel spawn from January to April in (Division IXa), from February to May in southern Biscay (Division VIIIc), March to July in the Celtic Sea and to the west of Ireland, from June to August in the North Sea (Divisions IVb and IIIa) (Section 3.7).

Therefore the amount of time available for growth and the formation of the opaque zone in the first year will vary within and between areas. It is therefore reasonable to expect a large amount of variation in the length of the L1 (first years growth on the otolith) and this should be borne in mind when interpreting the first opaque and translucent zones. In addition to the variation in L1 between areas, it is also been demonstrated that there is considerable variation in the L1 between years for the Celtic Sea and the North Sea (Dawson, 1991). The reader therefore, when interpreting the ring structure should be aware of sources of variation that may affect the nature of annual ring formation in the first year.

6.3.6.2 Age at maturity

In the majority of mackerel otoliths examined, there is a change in the pattern of ring formation that is presumably associated with the onset of maturity. Usually, growth slows down when the fish diverts much of its energy into gonad maturation. The resultant effect on the otolith is that for juvenile fish a large amount of opaque growth is produced between much narrower translucent rings. After maturity, growth slows down and both the opaque and the translucent rings become narrower and therefore closer together.

The above description is only a guide to the pattern of ring formation and obviously there is much variation in the age at maturity within an area as well as between areas. It is also possible that this change in the pattern of ring formation associated with maturity is not present. Sometimes otoliths may be observed to have very regular, clearly defined ring formation with only a linear decline in growth rate.

6.3.6.3 Reduced growth in very old fish

In most young and middle aged fish, the growth pattern is well defined on the otolith with clear contrasting opaque and hyaline zones. However in old fish, growth often slows down to such an extent that the opaque and translucent (hyaline) zones become confused and more difficult to distinguish. That portion of the otolith will have a greyish appearance. When this type of ring formation is observed, the reader usually finds that the translucent (hyaline) rings are very close together and difficult to identify. However, usually each narrow translucent (hyaline) ring and opaque ring represents one year's growth.

7 Collation of a set of agreed age otoliths (part of ToR e)

The WKARMAC decided to perform a post-WK exchange to test the agreed guidelines for age estimation of mackerel, in particular to relate to the recent changes in mackerel biology which could give the different patterns in the otolith which readers are observing (when following the existing manuals). The otoliths from this 3rd exchange will form the basis of a reference collection of agreed age otoliths, which should be maintained and updated with a frequency of four year intervals.

The exchange will consist of 251 images from Germany, Norway, Iceland, England and Spain in roughly equal numbers, covering as many sea areas as possible. The images will be viewed applying the age determination criteria established at the workshop and not the current criteria of individual institutes. This will ensure the criteria are properly tested and assessed by reviewing the agreement rates of the exchange. No image marking is required in the first instance as it is more important to get the results early, make the assessment of the criteria so that they can be verified for the report of the workshop.

8 Recommendations for further cooperation, exchanges, workshops and other actions in relation to the age estimation of Mackerel (part of ToRe)

8.1 General recommendations

Annex 3 holds all agreed recommendations and the designated groups for which the recommendations are made.

The workshop achieved quite a lot in terms of ironing out, through discussion and calibration, some of the major problems in ageing mackerel otoliths. The group reached agreement on a definition of an ageing protocol/guidelines mentioned in the present report and the aim is to employ these guidelines to eliminate some of the problems with e.g. split rings in the otolith structures. The group strongly recommends that all ageing laboratories processing mackerel should include the guidelines developed during the workshop in their ageing manuals. If possible the ICES system should facilitate the distribution of these guidelines to all relevant laboratories. For the sake of continuity, it is highly recommended that new readers are trained by experienced readers prior to delivering data to the assessment on mackerel. The workshop exercise clearly showed a difference in the level of agreements between experienced readers and then the large group of readers with varying degree of experience.

All participants in the workshop agreed to follow the defined guidelines in the present report for the decided upcoming exchange of images to facilitate an evaluation of the guidelines.

Through the discussions at the workshop it became apparent that the various life history traits for the mackerel have changed recently and that knowledge of this is highly important for the age readers. In addition, all age readers would benefit from more information on the formation of otolith structures in mackerel, especially the formation of split rings and the seasonally dependent appearance of the otolith edge. Thus, the group recommends the inclusion of such studies on otolith formation in general for mackerel.

Below are some general recommendations by the group for further action.

8.1.1 Manual

The age reading manual produced at this workshop should be maintained and further developed in the future. The report should be published e.g. through CORDIS.

8.1.2 Standardised reading within laboratories.

It is essential that otolith readers, whether fully trained or otherwise, have their work quality controlled. There are two main reasons for this. The first is that by conducting quality control, extremely valuable evidence of the precision of an age determination programme can be obtained. It is vital that the ages assigned to otoliths that are used in assessments are assigned the “best” age, given the methods at our disposal. As the actual age of the fish is unknown, age determination experts need to ensure the age provided is as close to the actual age as possible and that the ages given are repeatable if the determinations are redone. By having two experts independently ageing the otoliths, we can give assurances about the reliability of the data.

Secondly, even the most experienced readers are capable of drifting away from their training over time and another reader looking at a sample of their reading to check

consistency will ensure no drift occurs. This effort to ensure consistency of interpretation is further enhanced with the use of reference collections. The quality controller (QC) will be a very experienced reader in the species and probably the stock concerned. In this way, the effectiveness of the age determination programme to produce consistent results can be assessed and assured.

When a reader has determined the age of the fish, whether by being checked or not, the QC should be given approximately 150 otoliths from the 2nd and 3rd quarters to re-age. These should be selected by someone else (the Co-ordinator of Age Determination), who selects the otoliths to be quality controlled to ensure that the QC does not influence the results by their selection and that the whole of the length and age ranges are represented. The middle two quarters are chosen as they cover the main growth period and therefore the areas of likely uncertainty over the age. The otoliths should be read by the QC without knowledge of the ages previously assigned. The results are then compared and any discrepancies notified to the reader to check.

It is anticipated that the agreement on this check will be at least 90%. Where QC agreement rates fall significantly below this level, the Co-ordinator of age determination should investigate the reasons with the reader and QC to see if there are any resolvable problems with the otoliths concerned. The QC should have instructions to follow in the event of a failure to make the agreed quality control agreement level and / or if the APE is greater than 3%. These can be seen in Table 8.1.2.1.

When the Co-ordinator of Age Determination is consulted at the end of this process, they should review the paperwork, the otoliths and the ages with both the reader and the QC, providing advice and guidance, attempting to resolve any unresolved ages with them. It is envisaged that by this point, enough of the differences can be resolved to ensure the agreement levels are reached. If this is not possible, the Co-ordinator of Age Determination will be the final arbiter of the age.

Action required if QC result falls below target:	
% below target	Action required
0.1 – 2.0	Review disagreements with the reader and establish an agreed age. If this proves impossible, contact the Co-ordinator of Age Determination for advice.
2.1 – 5.0	Check for obvious errors the reader may have made (skipping fish or rows etc), establish the pattern in reading (under-ageing, over-ageing, edge problems etc). Review disagreements with the reader and establish an agreed age. If this proves impossible, contact the Co-ordinator of Age Determination for advice.
5.1+	Contact the Co-ordinator of Age Determination immediately.
Action required if the APE is greater than 3%:	
% Agreement	Action required
Above QC target	There may be a problem with the readers' interpretation of younger fish. Review disagreements with reader.
Below QC target	Contact Co-ordinator of Age Determination immediately as it may be necessary to conduct more checks than a standard QC.

Table 8.1.2.1: Actions to be taken by the QC if agreement rate falls below the target.

8.1.3 Quality control between labs.

Quality control of age estimations between national laboratories can be achieved in at least two ways;

- The standard exchange programme and workshops under the ICES programme. Readers read a set of otoliths and are compared with a modal age. This provides a snapshot of the agreement between readers, both expert and trainees, for the year in which the exchange or workshop takes place. It is particularly useful as many laboratories can take part and results compared. It can be used to confirm the validity of a laboratory's ageing criteria and interpretation or show problems. Exchanges and workshops can be expensive, slow to organise and therefore results are slow in arriving.
- A small scale, ad hoc exchange or workshop between two or more laboratories looking at a specific stock or sub-stock of the species, incorporating just those countries that have a direct interest in the stock. This type of approach is particularly useful to ensure that ages submitted to the stock assessment process are comparable. This type of exchange or workshop is inexpensive and can be done quickly to address the issues.

8.1.4 Regular workshops

The past frequency of workshops has been more or less decadal, which certainly does not cover the requirement for intra laboratory quality control of the age estimation of mackerel. Several factors need to be considered when deciding upon the frequency of workshops; there is the constant changing in behaviour of mackerel, which heavily influence the otolith morphology and thus the patterns to interpret. Also there is a flow of age readers through the laboratories, which need to be considered. It should be ensured that all labs do have at least one age reader acquainted with the agreed guidelines for age estimations of mackerel. Additionally there is always a need to update the flow of information between age readers, data collectors and end users. Thus WKARMAC recommends the inclusion of both assessment experts and age readers in future workshops. It proved very valuable for WKARMAC to have the previous chair of WGWIDE present at the workshop during discussions of results and their potential consequences.

9 References

- Anon., 1987a. Report of the Mackerel Age Determination Workshop, Lowestoft, 1-6 June 1987.
- Anon., 1993b. Report of the Mackerel and Horse Mackerel Egg Production Workshop. ICES C.M. 1990/H:4, 142pp.
- Anon., 1994. Report of the Workshop on Sampling Strategies for Age and Maturity. ICES C.M. 1994\D:1, 67pp.
- Anon. 1995. Report of the Workshop on Mackerel Otolith Reading. ICES CM 1995/H:1,45pp.
- Agnalt, A. L. 1989. Longterm changes in growth and age at maturity of mackerel, *Scomber scombrus* L. *Journal of Fish Biology*, 35(Suppl. A): 305 – 311.
- Bez, N., Rivoirard, J., and Walsh, M. 1995. On the relation between fish density and sea surface temperature. Application to mackerel egg density. ICES CM 1995/D:6 Ref C,H,L.
- Combs, S. H. and Mitchell, C. E. 1981. Long-term trends in the distribution, abundance and seasonal occurrence of larvae of mackerel (*Scomber scombrus* L.) around the British Isles, 1948-1978. *J. Mar. Biol. Ass. U.K.*, 61: 343-358.
- Dawson, W.A. 1986. Analysis of the Mackerel (*Scomber scombrus* L.) Otolith Exchange Programme. ICES CM 1986/H: 25, 20 p.
- Dawson, W.A. 1987. Report of the Mackerel age determination Workshop. Lowestoft, 1-6 June 1987.
- Dawson, Wendy A. 1991. Otolith measurement as a method of identifying factors effecting first-years growth and stock separation of mackerel (*Scomber scombrus* L.). *J. Cons. Int. Explor. Mer.*, 47: 303-317.
- FISHBASE (last accessed: 13 october 2007). *Scomber Scombrus*. <http://www.fishbase.org/Summary/speciesSummary.php?ID=118&genusname=Scomber&speciesname=scombrus>.
- Francis, R.I.C.C., Harley, S.J., Campana, S.E., Doering-Arjes, P., 2005. Use of otolith weight in length-mediated estimation of proportions at age. *Mar. Freshwater Res.* 56, 735-743.
- Gordo, L.S., Marins, M.M.B., and Jorge, I.M. 1982. Preliminary study on the age and growth of Mackerel (*Scomber scombrus* L.) in the ICES Sub-area IX. ICES C.M. 1982/H:16.
- Hamre, J. 1980. Biology, exploitation and management of the northeast Atlantic mackerel. *Rapp. P.-v. Réun. Cons. Int. Explor. Mer.* 177: 212-242.
- Hüssy, K, Jansen, T, and Clausen, Lotte Worsøe 2010. The use of otolith surface area in age determination of mackerel. WD to the WKARMAC 2010; Annex 5 to the present report.
- ICES Cooperative Research Report No. 301 | 141
- ICES. (2008) Report of the Working Group on Mackerel and Horse Mackerel Egg Surveys. ICES CM 2008/LRC:09.
- Iversen, S. A. 1981. Spawning and trends in spawning stock size of the North Sea Mackerel during the period 1973-80. ICES C.M. 1981/H:16, 9pp.
- Kristensen, K, Lewy, P and Beber, J.E. 2006. How to validate a length-based model of single-species fish stock dynamics. *Can. Jour of Fisheries and Aquatic Sciences*, 63 (11): 2531-2542
- Lago de Lanzós, A., Solá, A. L., Motos and Franco, C. 1993 Mackerel (*Scomber scombrus* L.) Egg Distribution and Stage I Egg Production Estimates in Division VIIIb,c and IXa north from 1988, 1990 and 1992. ICES. C.M. 1993/H:44, 11pp.
- Lockwood, S.J., Nichols, J. H. and Dawson, Wendy A. 1981. The estimation of a mackerel (*Scomber scombrus* L.) spawning stock size by plankton survey. *J. Plank. Res.*, 3: 217-233.
- Mendiola, D and Álvarez, P. 2008. Validation of daily increments in the otolith microstructure of Northeast Atlantic mackerel fish larvae. *Fisheries Research* 89 (2008): 300-304

- Muus, B.J., and Nielsen, J.G. 1999. Sea fish. Scandinavian Fishing Year Book, Hedehusene, Denmark, p. 340.
- Muus, B.J., Nielsen, J.G., Dahlstrom, P., and Nyström, B.O. 1997. Zeevissen van Noord- en West-Europa. Schuyt & Co Uitgevers en Importeurs BV, Haarlem. Neja, 1995
- Olaso, I., J.L. Gutiérrez, B. Villamor, P. Carrera, L. Valdés and P. Abaunza, 2005. . 2005. Seasonal changes in the north-eastern Atlantic mackerel diet (*Scomber scombrus*) in the north of Spain (ICES Division VIIIc). *J. Mar. Biol. Ass. UK*, 85(2): 415-418. Overholtz, 1989;
- Punzón, A. and Villamor, B. (2009) Does the timing of the spawning migration change for southern component of North East Atlantic Mackerel (*Scomber scombrus*, L. 1758)? A approximation by the fishery analyses. *Cont. Shelf Res.* 29: 1195–1204
- Reid, D.G. 2001. SEFOS -- shelf edge fisheries and oceanography studies: an overview. *Fisheries Research*, 50(1-2): 1-15.
- Reid, D.G., Walsh, M., and Turrell, W.R. 2001. Hydrography and mackerel distribution on the shelf edge west of the Norwegian deeps. *Fisheries Research*, 50(1-2): 141-150.
- Röckmann, C and Dickey-Collas, M. 2010: ICES Cooperative Research Report N° 301, May 2010
- Solá, A., Lago de Lanzós, A. and Franco, C. 1994. Seasonal occurrence of mackerel and horse mackerel eggs and larvae in the Cantabrian Sea (VIIIc) and Galicia (IXa) from 1990 to 1992. WD 1994, in ICES C.M. 1994/H:4, 58pp.
- Scott, W.B., and Scott, M.G. 1988. Atlantic fishes of Canada. *Can. Bull. Fish. Aquat. Sci.*, 219: 731 pp.
- SEFOS. (1997) Shelf Edge Fisheries and Oceanography Study (SEFOS). Project, Contract AIR No. CT93-1105, Final Report, 1997. Brussels: European Commission, DG XIV.
- Villamor, B. & M. Meixide. 1995. Results of the Mackerel (*Scomber scombrus*, L.) otolith exchange programme in 1994. *ICES CM 1995/H: 12*, 31 p.
- Villamor, B., Bernal, M. and Hernández, C. (2004a) Models describing Mackerel (*Scomber scombrus*) early life growth in the North and Northwest of the Iberian Peninsula in 2000. *Sci. Mar.* 68(4): 571-583.
- Villamor, B., Abaunza, P. and Fariña, C. (2004b) Growth variability of mackerel (*Scomber scombrus*) off North and Northwest Spain and a comparative review of the growth patterns in the Northeast Atlantic. *Fish. Res.* 69: 107-121.
- Walsh, M., Reid, D.G., and Turrell, W.R. 1995. Understanding mackerel migration off Scotland: Tracking with echo sounders and commercial data, and including environmental correlates and behaviour. *ICES J. Mar. Sci.*, 52(6): 925-939.

Annex 1: Agenda

Monday, November 1st, 2010	
13:00 – 13:30	Welcome; agreement on the agenda and participants; practicalities, etc.
13:30 – 15:00	Presentation of the exchange results, including on-screen discussion of relevant otolith readings
15:00 – 17:00	Review information on age estimations, otolith exchanges, workshops and validation work done so far.
17:00 – 18:00	Drafting the Table of Contents for an ageing manual
Tuesday, November 2nd, 2010	
09:00 – 12:00	Age-reading exercise; a 're-run' of the exercise performed prior to the wk using OMAP
12:00 – 13:00	Lunch
13:00 – 14:00	Revise the age estimation procedures and explore the possibilities to use supplementary information for validating estimated age structures
14:00 – 15:00	Plenary re the progress on manual writing; discussion on ways to proceed
15:00 – 17:30	Working in sub-groups on the manual and draft report
17:30 – 18:00	Concluding and summing up the day's work, plans for progress
Wednesday, November 3rd, 2010	
09:00 – 09:30	Summing up progress on manual and draft report; assignment of tasks
09:30 – 12:00	On screen debate on interpretation criteria of mackerel otolith structures using material from the exchange. Aiming at an agreed age collection.
12:00 – 13:00	Lunch
13:00 – 14:00	Resolve interpretation differences between readers and laboratories by performing an in depth analysis of difference in age reader interpretation of otolith spatial patterns and explore the usage of metric measurements of otolith structures as a solution to minimize the divergence in age estimation (based on exchange otoliths where age structures have been identified by all readers) – this could lead to collation of a set of agreed-age otoliths for a reference collection
14:00 – 17:00	Further development of a common manual for age determination of mackerel (writing, plotting, discussing, etc)
19:30 – 2200	Social event.
Thursday, November 4th, 2010	
09:00 – 12:00	Plenary reading of the manual as it stands – reaching perfect agreement on age estimation criteria Plenary discussion of WKARMAC recommendations, including input from WGWISE; discuss further cooperation between age readers, otolith sample exchange, bilateral cooperation, and workshops Working in sub-groups to finalize drafts
12:00 – 13:00	Lunch – and time for goodbyes and bon voyage's...

Annex 2: List of participants

NAME	ADDRESS	PHONE/FAX	EMAIL
Matthias Bernreuther	Johann Heinrich von Thünen-Institute, Federal Research Institute for Rural Areas, Forestry and Fisheries Palmaille 9 D-22767 Hamburg Germany		Matthias.Bernreuther@vti.bund.de
Lotte Worsøe Clausen Chair	DTU Aqua - National Institute of Aquatic Resources Section for Fisheries Advice Charlottenlund Slot Jægersborg Alle 1 DK-2920 Charlottenlund Denmark	Phone +45 21362804 Fax +45 33963333	law@aqua.dtu.dk
Jean Louis Dufour	IFREMER Boulogne-sur-Mer Centre P.O. Box 699 62321 Boulogne Cédex France		Jean.Louis.Dufour@ifremer.fr
Andre Dijkman Dulkes	Wageningen IMARES P.O. Box 68 NL-1970 AB IJmuiden Netherlands		andre.dijkman@wur.nl
Mark Etherton	Centre for Environment, Fisheries and Aquaculture Science Lowestoft Laboratory Pakefield Road NR33 0HT Lowestoft Suffolk United Kingdom	Phone 1502 524539 Fax 1502 513865	mark.etherton@cefas.co.uk
Jerome Felix	IFREMER 155, rue Jean-Jacques Rousseau, Technopolis 40 92138 Issy-les-Moulineaux France		jerome.felix@ifremer.fr
Gudrun Finnbogadóttir	Marine Research Institute PO Box 1390 IS-121 Reykjavik Iceland		gunna@hafro.is
Gudrun Gentschow	Johann Heinrich von Thünen-Institute, Federal Research Institute for Rural Areas, Forestry and Fisheries Palmaille 9 D-22767 Hamburg Germany		gudrun.gentschow@vti.bund.de

NAME	ADDRESS	PHONE/FAX	EMAIL
Owen Goudie	Marine Scotland Marine Laboratory Aberdeen P.O. Box 101 AB11 9DB Aberdeen United Kingdom		O.J.Goudie@marlab.ac.uk
Eilert Hermansen	Institute of Marine Research P.O. Box 1870 N-5817 Bergen Norway		eilert.hermansen@imr.no
Alison Holmes	Centre for Environment, Fisheries and Aquaculture Science Lowestoft Laboratory Pakefield Road NR33 0HT Lowestoft Suffolk United Kingdom		Alison.holmes@cefasc.co.uk
Maria Jarnum	DTU Aqua - National Institute of Aquatic Resources Jægersborg Allé 1 DK-2920 Charlottenlund Denmark		mja@aqua.dtu.dk
Anne-Liv Johnsen	Institute of Marine Research P.O. Box 1870 N-5817 Bergen Norway		anneliv@IMR.no
Jan de Lange	Institute of Marine Research P.O. Box 1870 N-5817 Bergen Norway		jan.de.lange@imr.no
Deirdre Lynch	Marine Institute Rinville Oranmore, Co. Galway Ireland.		deirdre.lynch@marine.ie
Maria Manuel Martins	INRB - IPIMAR Avenida de Brasilia 1449-006 Lisbon Portugal		mane@ipimar.pt
Eugene Mullins	Marine Institute Killybegs Harbour centre, Killybegs, Co. Donegal. Ireland.		eugene.mullins@marine.ie
Maria Rosario Navarro Rodriguez (Charo Navarro)	Instituto Español de Oceanografía. Centro Oceanográfico de Santander Promontorio de San Martín, S/N. E-39004 Santander (Cantabria) Spain		charo.navarro@st.ieo.es

NAME	ADDRESS	PHONE/FAX	EMAIL
Iñaki Rico	AZTI-Tecnalia AZTI Pasaia Herrera Kaia Portualde z/g E-20110 Pasaia (Gipuzkoa) Spain		irico@azti.es
Robert Watret	Marine Scotland Marine Laboratory Aberdeen P.O. Box 101 AB11 9DB Aberdeen United Kingdom	Phone +44 (0) 1224 295422	watret@marlab.ac.uk
Ines Wilhelms	Johann Heinrich von Thünen- Institute, Federal Research Institute for Rural Areas, Forestry and Fisheries Palmaille 9 D-22767 Hamburg Germany		ines.wilhelms@vti.bund.de

Annex 3: Recommendations

The WKARMAC strongly recommends a solid study on the edge development of mackerel otoliths due to the recent changes in otolith morphology. The appearance of the otolith edge in a given area and season appears to have changed in recent years, causing the majority of the disagreements between the readers of mackerel otoliths. In particular, attention should be paid to the younger individuals and the appearance of the edge over the season depending on area.

The existence of otoliths from the Norwegian Mark-Recapture experiments is potentially the golden stones and could iron out many subjective assumptions relating to the age estimation of mackerel from this area (and potentially other areas). It is of utmost importance that the dimensions and availability of such material is clarified and that efforts are made to reach agreement on potential availability for coordinated validation studies.

The WKARMAC strongly recommends the application of the Reading-Grade by all laboratories applying data for the assessment. This would increase the possibility to make a valid judgement of the quality of the assessment.

The WKARMAC highly recommends the application of the criteria for age reading stated in the manual by all laboratories applying data to the assessment working group. Ideally the guidelines found in the manual produced during the WKARMAC should form the backbone of all manuals applied when age estimating mackerel otoliths.

The WKARMAC recommends a higher degree of continuity of readers of mackerel in the future to avoid a total shift of generations as seen recently. This would facilitate a continued common perception of otolith structures and also ensure that changes in these would be detected.

The WKARMAC recommends a study of the area specific summer growth in the otoliths making a comparison between areas possible. This would facilitate a correct interpretation of the growth zones. In connection with such a study it would be highly warranted to achieve a quantitative estimate of the degree of migration between the areas.

The WKARMAC recommends efforts put into an analysis of acceptable variance around the estimated proportions at age for mackerel. The overall agreement in all previous workshops and the WKARMAC was never more than around 70% and it is doubtful whether it is possible to reach higher levels of agreements for the older part of the mackerel population. The WKARMAC has reconfirmed the validity of the age estimations up to age 4 using the existing methodology. The validated range of ages would without doubt be increased dramatically if the recommendations concerning studies of the otolith morphology (particular the otolith edge and the known-age otoliths held by Norway) are followed.

The WKARMAC recommends a revision of what is known of Mackerel biology; apparently the spawning time has shifted/prolonged in some areas which could influence the appearance of the otolith.

The WKARMAC is setting up a follow-up exchange to evaluate the agreed guidelines for age estimation of mackerel. The results will be the foundation of a reference collection. The results will be available in the beginning of 2011 as an addendum to the present report.

RECOMMENDATION	FOR FOLLOW UP BY:
1. Study of otolith morphology, particular the edge structures	PGCCDBS
2. Age validation applying mark-recapture otoliths	PGCCDBS and bilateral negotiations with IMR, Bergen
3. Application of the Reading-Grading-System	PGCCDBS
4. Application of the manual agreed by WKARMAC by all ageing laboratories	PGCCDBS and in turn all institutes delivering mackerel data
5. Study of the area specific otolith growth and the degree of stock mixing	SCICOM
6. Study of the acceptable degree of variance around age estimates for mackerel	WGWIDE
7. Revision of general mackerel biology	SCICOM

Annex 4: State of the art of known mackerel biology

Introduction

This section reviews knowledge of the mackerel (*Scomber scombrus*; order *Perciformes*, family *Scombridae*) in relation to the effects of climate change on the distribution and the production of the stocks, and focuses on observed changes as well as underlying mechanisms. The revision is part of the ICES Cooperative Research Report N° 301, May 2010 by Christine Röckmann and Mark Dickey-Collas.

General biology

The mackerel is a species of commercial importance and also a game fish. A pelagic, ocean and coastal dwelling species, it has a depth range of 0–1000 m. Occurring between 25°N – 70°N and 77°W – 42°E, the mackerel is considered a temperate fish species that inhabits the eastern Atlantic, southwestern Baltic Sea, Mediterranean and Black seas, and the western Atlantic from Labrador to Cape Lookout (North Carolina). Mackerel are abundant in cold and temperate shelf areas, forming large schools close to the surface. They overwinter in deeper waters, but move closer to shore in spring, when water temperatures range between 11 °C and 14 °C (FishBase, 2007; Muus *et al.*, 1997; Muus and Nielsen, 1999).

ICES currently uses the term “Northeast Atlantic mackerel” to define the mackerel present in the area extending from ICES Division IXa in the south to Division IIa in the north, including mackerel in the North Sea and Division IIIa. Mackerel migrate extensively between their winter feeding grounds and more southern spring and summer spawning grounds. The spawning areas of mackerel are widespread, but only the stock in the North Sea is sufficiently distinct to be clearly identified as a separate spawning component. In order to keep track of the development of the spawning biomass in the different spawning areas, the Northeast Atlantic mackerel stock is divided by area into three components: the western spawning component, the North Sea spawning component, and the southern spawning component. In parts of the year, the three components have overlapping distributions, and a part of the southern component is fished in the northern area.

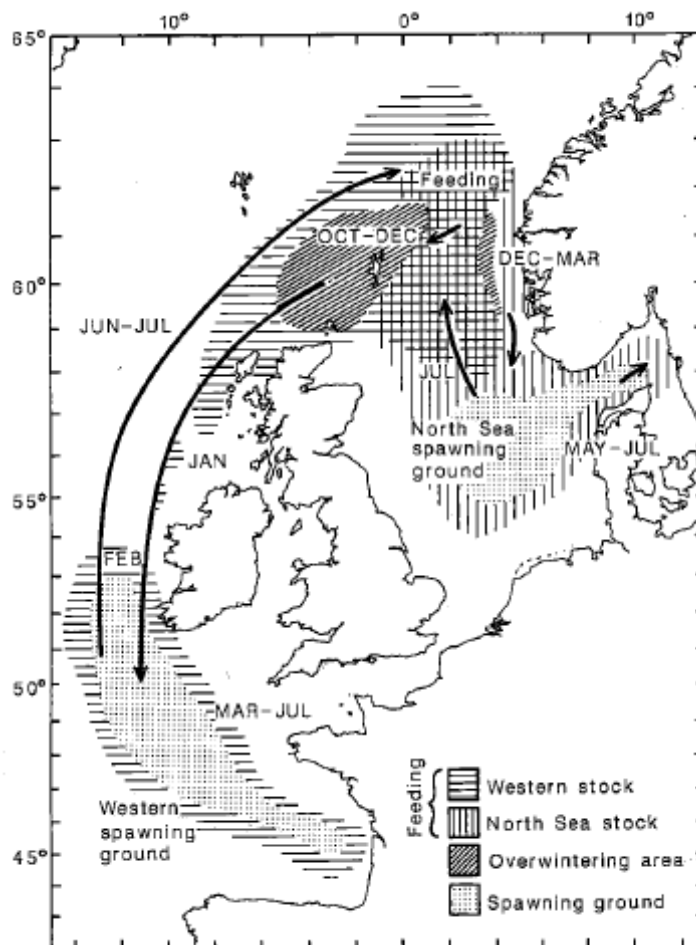

Mackerel mature at around the end of age 3 and at a length of ca. 30 cm. Mackerel spawn its eggs in the European shelf edge from the south of the Iberian Peninsula to the west of Scotland (ICES 2008). The main spawning areas are concentrated in the west and southwest of Ireland, the Celtic Sea slope, and in the Cantabrian Sea (SEFOS, 1997). Spawning occurs from January to July. In the Cantabrian Sea, mackerel spawn mainly in March – April, west of Ireland they spawn in May – June, and in the North Sea they spawn in June- July. Peak spawning has been reported to occur in April off Cantabrian Sea and in May off southwest Ireland. The spawning migration path follows the shelf edge for most of its route, with the fish being found generally between the 100 m and 250 m contours (Walsh *et al.*, 1995). Mackerel are batch spawners. Close to the surface, females lay ca. 200 000 – 450 000 eggs, and larvae are 3 – 4 mm long at ca. 6 days post hatching. Eggs and larvae are pelagic. Mackerel growth is very fast in the first months, reaching 22 cm at the end of the year in which they were born, age group 0 (Villamor *et al.*, 2004a).

After spawning, the adults forage very actively in small shoals. Adults exhibit diurnal feeding activity, and diets consist of zooplankton and small fish, such as young cod (*Gadus morhua*), herring (*Clupea harengus*), sprat (*Sprattus sprattus*), and sandeel (*Ammodytes marinus*). The most important feeding areas are located around the Shetland Islands and in the northern North Sea. The diet of the juveniles in spring consists of euphausiids, crustacean larvae, and other zooplankton. Euphausiids were reported to form 90 % of the spring diet in adults. In autumn, juveniles were reported to eat hyperiids and gelatinous zooplankton, whereas adults targeted blue whiting (*Micromesistius poutassou*; Olaso *et al.*, 2005). During the long distance feeding migration,

mackerel can form schools that are 200 m wide and extend to a depth of 100 m. School density can be ca. 9 fish m⁻³ (Walsh *et al.*, 1995; Muus *et al.*, 1997; Muus and Nielsen, 1999).

Mackerel are preyed upon by the porbeagle shark (*Lamna nasus*), spiny dogfish (*Squalus acanthias*), cod, bluefin tuna (*Thunnus thynnus*), swordfish (*Xiphias gladius*), harbour porpoise (*Phocoena phocoena*), and harbour seal (*Phoca vitulina*). Parasites of the species include the monogenean *Kuhnia scombri* on the gills, trematodes (*Podocotyle atomon* and *P. simplex*), and nematodes (*Anisakis simplex* and *Haematractidium scombri*; Scott and Scott, 1988).

Mackerel can attain a maximum size of 60 cm (Muus and Nielsen, 1999). The maximum published weight of a mackerel is 3.4 kg (Frimodt, 1995), and the maximum reported age is 17 years. Mackerel do not have a swimbladder and can therefore quickly change depth without suffering from pressure differences.

Observed changes in production

Variability in annual growth rates of Northeast Atlantic mackerel may be influenced by environmental factors as well as by population and life history factors. During their migrations, adult mackerel are subject to highly variable environmental conditions (e.g. upwelling), which influence their growth and reproductive potential and may have a major effect on juvenile growth. Dawson (1986) and Villamor *et al.* (2004) hypothesized that growth differences between mackerel in different areas are caused by gradual spatial and temporal changes in length at age during migration. The largest fish of a certain age can migrate greater distances, reach spawning areas earlier, and leave for feeding areas earlier than smaller ones. This would lead to successive changes in length and weight at age and, thus, a variable growth pattern along the geographic distribution range of the species.

Another cause of variability in mackerel growth rate may be the effect of population density, which particularly affects growth of the youngest ages. Agnalt (1989) estimated a negative correlation between the mean length at ages 1 and 2 and the North Sea mackerel stock biomass in the 1970s. Similar findings were reported for the Northwest Atlantic (Overholtz, 1989; Neja, 1995). Moreover, Agnalt (1989) reported that mean length and weight at age of Atlantic mackerel in the North Sea increased significantly between 1960 and 1979, but decreased markedly during the 1980s. In contrast, median age at maturity decreased from 1960. Median length at maturity remained stable until the 1980s, when it declined sharply.

Changes during the 1980s may have resulted from immigration of the western mackerel stock. One should be cautious when interpreting data on growth studies, as input data in growth studies is often biased, especially for migratory species like mackerel. Samples might be unrepresentative owing to missing elements, as the whole cohort may not be present in the area where the samples are taken. Moreover, the interpretation of growth depends on the season when samples are obtained.

Observed changes in distribution

Some surveys and fisheries for other species found changes in the distribution of mackerel, with a decrease in abundance in the south and an increase in the north and west, and in the Skagerrak and Kattegat (ICES, 2007c). A shift in spawning area and period has also been indicated. French acoustic surveys in Divisions VIIIa and VIIIb in May demonstrated a reduction in adult Northeast Atlantic mackerel within the

survey area in both 2006 and 2007 when compared with previous studies. This suggests a northward shift in mackerel distribution in recent years (ICES, 2007i).

Furthermore, analysis of egg survey data suggests that mackerel appeared to be spawning slightly earlier farther north and farther west of the shelf break over the past 20 years (Bez *et al.*, 1995; Reid, 2001). These changes may have implications for the growth, pattern of transport, and survival of larvae and, thus, may affect both stock dynamics and fisheries.

Changes in the Spanish fishery as well as survey results hint at changes in mackerel distribution. The Spanish fishery in Divisions VIIIb and VIIIc has, since 2000, started and ended earlier than in previous years (Punzón and Villamor, 2009). Surveys confirmed the indication of a temporal shift of approximately one month in the migration pattern of mackerel in the southern area, which might be linked to a more northerly distribution pattern (ICES, 2007i).

Processes underlying observed changes.

It has been hypothesized that changes in Northeast Atlantic mackerel production are related to stock size as well as to environmental conditions, the former possibly affecting growth of the youngest fish and the latter possibly affecting the growth and spawning potential of adults, as well as juvenile and larval growth. The shift in distribution may be explained by a combination of variability in hydrographic factors and indirect effects (such as plankton abundance), as well as life history aspects. The following factors have been explicitly suggested in the literature to interact with, and to affect, changes in mackerel production and distribution:

- Zooplankton
- Abundance in spawning area
- Abundance, availability, and suitability as larval food source
- Ocean circulation patterns
- Temperature

Direct links between climate change and changes in distribution and production specifically of Northeast Atlantic mackerel have yet to be studied. However, some indirect links with climate change, via one of the above listed factors, have been studied (ICES Cooperative Research Report No. 301 | 141).

Conclusion

Mackerel is a species with a high level of natural variability in abundance. In addition to this natural variability, changes in production and distribution have been observed over the past four decades. Three main intermediate factors are proposed in the literature as potentially affecting mackerel population dynamics: zooplankton abundance, ocean circulation patterns, and temperature.

It is well known that global climate change affects zooplankton abundance and distribution as well as ocean temperature and ocean circulation patterns. However, how climate change will affect the Northeast Atlantic mackerel stock, specifically via these intermediate factors, requires further study.

Annex 5. WD by Hüsey *et al.* 2010 ‘The use of otolith surface area in age determination of mackerel’

Karin Hüsey, Teunis Jansen and Lotte Worsøe Clausen

DTU-AQUA, Denmark

Abstract

1091 otoliths from spawning mackerel (maturity stage 6), sampled by IMARES from commercial catches and egg surveys in 2002, 2003, 2007 and 2008 in ICES sub area IV and VII, were photographed. The images were analysed in OMAP v.1.3 (Jansen, 2010). The visible area facing the camera and was analysed as a potential biometric for LMMA.

We found no more age dependant information in area than in fish length.

In conclusion; we do not recommend using otolith area as an additional biometric for ageing North East Atlantic mackerel.

Introduction

Background:

In assessment context, the result of age determination exercises is to determine catch proportions at age. The goal of the age determination is thus not individual ages but rather proportions of each age class at the population level. A method estimating these proportions on the basis of routine samples therefore appears desirable. Most approaches developed to achieve this suffer from asymptotic bias - i.e. bias does not tend to zero at large sample sizes. The four types of bias found in all early methods are:

- i) Discriminant bias: Associated with specific types of ‘cutting rule’ in splitting overlapping distributions
- ii) Smoothing bias: Occur when variation in proportion at age are ignored, leading to ‘smoothing’ of age-classes.
- iii) Heteroscedastic bias: Occur when variation in variance by age are ignored
- iv) Calibration bias: Occur when proportions at age in the calibration sample are different from those in the population.

The Length-Mediated Mixture Analysis (LMMA):

An alternative approach, which produces unbiased estimates is the so called “Length-Mediated Mixture Analysis” (LMMA). This method has been developed by (Francis *et al.*, 2005) based on known-age Faroese cod and aims at estimating the age distribution in a population, rather than individual ages. The fish size - otolith size relationship of the sample used is shown in figure 1.

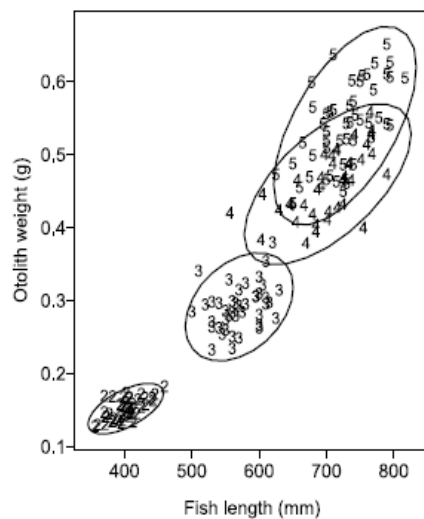

Figure 1: The fish length-otolith weight relationship of known-age Faroese cod. (From Francis and Campana, Can. J. Fish. Aquat. Sci., Vol- 61, 2004)

The LMMA involves three types of samples, a production sample, where fish length and otolith weight is known, a calibration sample, where the fish's age is also known and the populations length distribution. The LMMA is an extension of the Mixture analysis model described by (Francis and Campana, 2004), and allows stratified sampling and the additional information of the populations length distribution. One of the advantages of the Mixture analysis is that it avoids asymptotic bias by using maximum likelihood estimation. Another advantage is that it is also possible to incorporate known ageing errors and makes use of the information given by the population's length distribution. The approach makes better use of the population's length distribution and may require a smaller calibration sample than the traditional method.

The LMME approach is based on a series of simple assumptions and a few requirements. In the following we will refer to length measurements as L , otolith biometrics as O and age A . The assumptions and requirements are:

Three samples: Calibration (LOA), Production (LO) and length (L). The Calibration sample may be a random sample or stratified random sample of the population while the Production sample is required to be a random sample if a random length sample is not available.

- Size and age range in LOA and LO sample are the same.
- Data must be multivariate normally distributed.
- Homoscedasticity of variation in the otolith size – fish size relationship
- If the number of age classes is high, then constraints on parameters are necessary.
- If samples are length-stratified, then the fish selection should be random at length.

The age distribution of the population is estimated using maximum likelihood. The likelihood function is described by the equation in Francis and Campana (2004) p. 1277 for the case where both samples are random:

$$\lambda = \lambda_c + \lambda_p$$

$$= \sum_i \log[p_{Ai} g(\mathbf{X}_i; \theta_{Ai})] + \sum_j \log[\sum p_A g(\mathbf{X}_j; \theta_A)],$$

where λ_c and λ_p are the log-likelihood components associated with the Calibration and the Production sample respectively, \mathbf{X} = vector containing otolith weight and fish length (\mathbf{X}_i ; for Calibration sample and \mathbf{X}_j for Production sample), p_A = proportion of fish of age A . The distribution of \mathbf{X} is given by the density function $g(\mathbf{X}_i; \theta_{Ai})$. Estimation is the result of the values of (p_A, θ_A) that maximise λ . Details of the analysis follow the description of Francis & Campana (2004) and Francis et al. (2005).

LMMA example: Baltic cod

Otoliths from Baltic cod are notorious difficult to read. During an EU-funded project DECODE (*ImproveD mEthodology for Baltic COD age Estimation* (FISH/2006/15; Studies and Pilot Projects for carrying out the common fisheries policy), the use of different methods as substitutes for the traditional ageing methods was evaluated.

The applicability of the LMMA to the Baltic cod stock proved easy. However, the precision of the age proportion estimates were the same, regardless whether otolith weight (the only biometric measure analysed) was included in the analysis or not. This lack of apparent gain from including otolith biometrics turned out to be attributable to the close relationship between fish length and otolith weight (see figure 2). There was simply is no additional information to be obtained by including the otolith weight. However, the linearity of this relationship ceases at larger fish sizes and the approach may therefore be a valuable tool for estimating the proportions of older age classes.

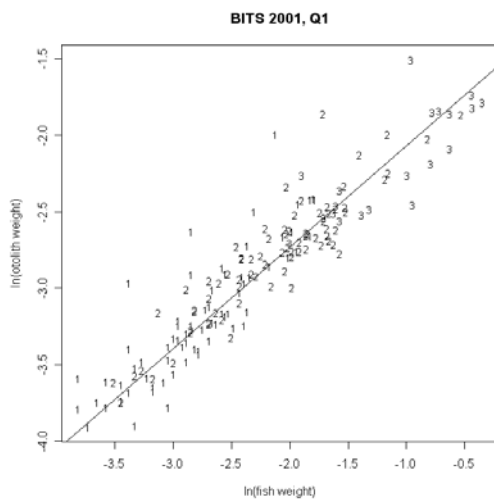

Figure 2: The relationship between fish weight and otolith weight of Baltic cod. Numbers indicate age classes (From the DECODE project report)

Materials and methods

1091 otoliths from spawning mackerel (maturity stage 6), sampled by IMARES from commercial catches and egg surveys in 2002, 2003, 2007 og 2008 in ICES sub area IV and VII, were photographed. The images were analysed in OMAP v.1.3 (Jansen, 2010 871 /id).

The visible area facing the camera and was analysed as a potential biometric for LMMA.

It was assumed that much of the noise in the Area-Age relationships, originated from the variation in juvenile growth. An attempt to account for this variation was made by reducing the area with a rough estimate of area inside the second to third winter ring ($L1 \cdot L1 \cdot 0.3$).

Results, Discussion and conclusion

At first glance, the mackerel data seem suitable for the application of the LMMA approach since the most fundamental requirements are fulfilled (figures 3 and 4):

Data is multivariate normally distributed.

Variation in the otolith size – fish size relationship is homoscedastic

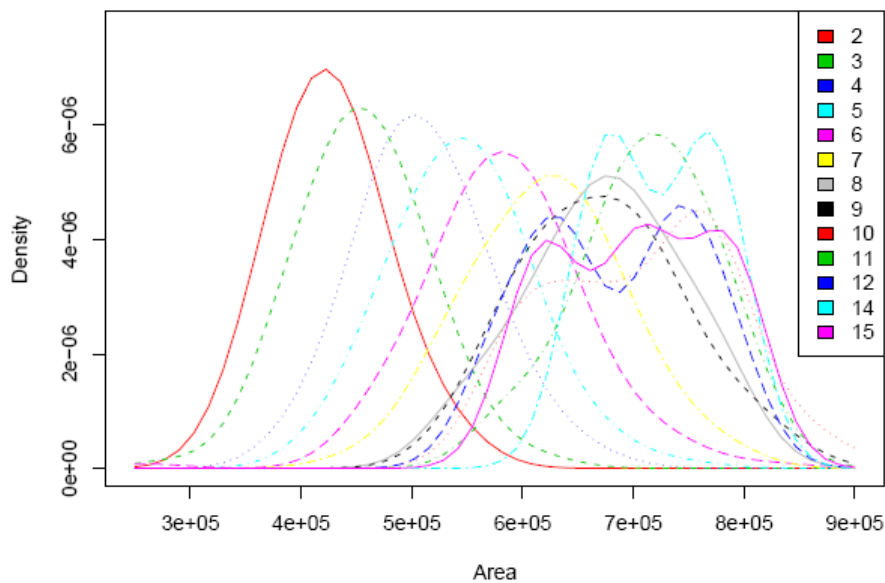

Figure 3: The distribution of mackerel otolith area by age class (colour coded according to the legend).

However, the fish size – otolith area relationship is linear over most of the age classes (figure 4). Therefore, no further information is gained from including otolith area. Accounting for juvenile growth, did not change this pattern.

In conclusion; we do not recommend using otolith area as an additional biometric for ageing North East Atlantic mackerel.

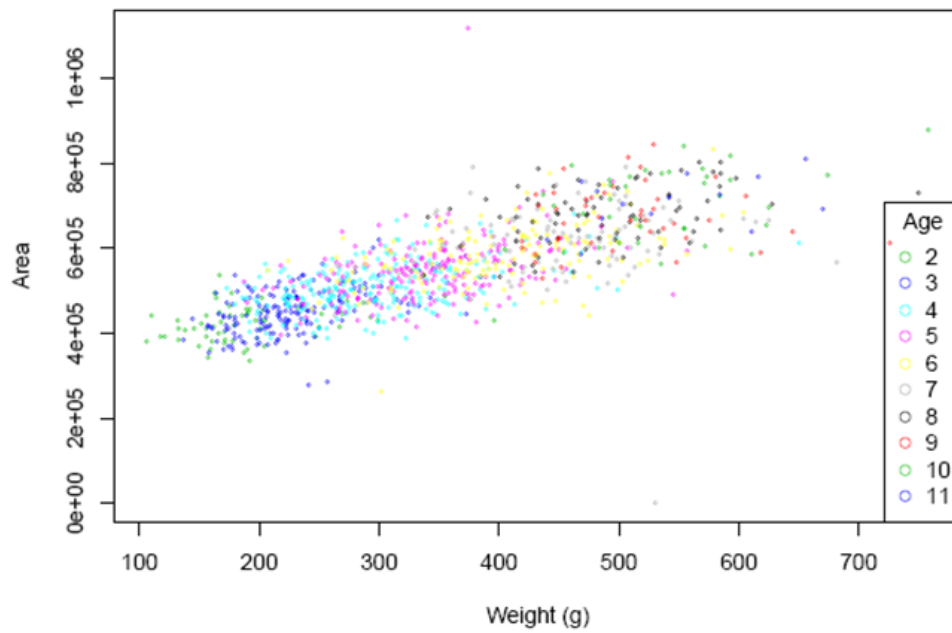

Figure 4: The otolith size – fish size of mackerel by age class (colour coded according to the legend).

References:

- Francis, R.I.C.C., Campana, S.E., 2004. Inferring age from otolith measurements: a review and a new approach. *Can. J. Fish. Aquat. Sci.* 61, 1269-1284.
- Francis, R.I.C.C., Harley, S.J., Campana, S.E., Doering-Arjes, P., 2005. Use of otolith weight in length-mediated estimation of proportions at age. *Mar. Freshwater Res.* 56, 735-743.
- Jansen, T. 2010. OMAP. Otolith Morphology Application. Open source software available by request to the author.

Annex 6 Results of the post-workshop exchange of mackerel (*Scomber scombrus*) otolith images 2010

Mark Etherton, Centre for Environment, Fisheries and Aquaculture Science (Cefas), Pakefield Road, Lowestoft, NR33 0HT, UK.

1- Introduction

The international mackerel age determination workshop (WKARMAC), held in Lowestoft, England from 1st-4th November 2010, highlighted the need for another exchange. This need arose from a poor level of agreement between readers in the exchange prior to the workshop and the need to put into practice a new set of age determination criteria that were established at the workshop. The criteria need to be tested to ensure that they provide the desired increase in agreement between readers and to ensure that the criteria are easy to follow so that in the future, new readers will be able to pick up the criteria quickly and establish good agreement with other readers applying the criteria to their age determinations.

This new exchange was organised by Cefas and was available immediately after the completion of the workshop. The exchange had a short timescale, and was completed by 7th December 2010. This short timescale was deliberately imposed to ensure the criteria the readers were asked to make the age determinations by were remembered and understood as well as providing the group with the potential of good news about the progress made as soon as possible. As well as endeavouring to increase agreement by the implementation of revised and updated ageing criteria, the post-workshop exchange sought to establish a reference collection of agreed age images to be used for future reference for all readers.

A total of 11 institutes took part in the exchange. Each institute was asked to provide one reading for each otolith image. That reading could be from one or multiple readers but must represent the considered view of the institute, reading the images in line with the age determination criteria established at the workshop. Although some institutes provide an age for each image derived from more than one reader, for the purposes of simplicity in the report, all institutes will be referred to as having one reader.

The software used to analyse the results was the ORACLE (Otolith Reading Age Comparisons, Like Eltinks') spreadsheet, developed by Mark Etherton of Cefas from the Eltink *et al* (2000) "Age Comparison Worksheet".

2 - The exchange sets

Otoliths were selected from as wide a geographical range as possible. Mackerel are highly migratory, and to truly reflect all of the possible otoliths a reader may find in their samples, otoliths should be viewed from as many sea areas as possible. In the short timescale available to us in the exchange, images of 5 sets of otoliths encompassing 252 pairs of otoliths were gathered. Images of the Norwegian, German and English sets were taken during the workshop, of otoliths brought to the workshop by the respective institutes. Images of the Spanish and Icelandic otolith sets were provided by those institutes in the days after the workshop. The summary of numbers and sea areas the exchange sets are from can be seen in Table 1.

Country of Origin	Sea Area	No. Males	No. Females	No. Unknown Sex	Total No.
Norway	IIa	22	23	3	48
Iceland	Vb	19	17	4	40
Germany	IV	29	30	1	60
England	VIIIf	23	37	0	60
Spain	VIII	21	23	0	44
Total		114	130	8	252

Table 1 – Summary of the exchange otoliths

3 - The exchange and issues arising

During the exchange, it became clear that 4 of the Icelandic otoliths would have a modal age of zero. The software used to analyse the results doesn't work with modal ages of zero, so these had to be removed from the results. However, as all readers gave the age of zero for these fish, no affect resulted from their removal. The total number of otoliths considered in the exchange was therefore 248.

Two countries, Norway and France, were unable to read both the Spanish and Icelandic otoliths. This was either due to limited availability of the readers or an opinion that the otoliths were unreadable from the images provided.

Most readers found that there were at least one or two images that they had difficulty in assigning an age to. A summary of the number read by each institute is given in Table 2.

Institute	Country	No. exchange images read
IMR	Norway	167
Cefas	England	248
IEO	Spain	247
WUR	Holland	248
IPIMAR	Portugal	233
VTI	Germany	247
Marine Scotland	Scotland	248
Marine Institute	Ireland	245
Hafro	Iceland	248
IFREMER	France	167
DTU-AQUA	Denmark	248

Table 2 – Number of exchange images read by institute

4 - Results

The results of the exchange are encouraging. The age determination criteria would appear to have had an effect on agreement rates. The pre-workshop exchange of 195 otoliths found only 12 otoliths (6%) where all 15 readers agreed on the age. This exchange of 248 otoliths had agreement from all readers (9 or 11 depending on sample) on 85 otoliths (34%). Of the 9 readers who read all samples, the agreement rate with the modal age ranged from 71.7% to 85.1%. The agreed modal ages for each sample can be seen in Table 3. The Icelandic and Spanish sets had much higher average ages than the other sets, the German set much lower than the others. One would expect greater agreement with the sets with lower average age, and agreement to fall away for the Icelandic and Spanish sets.

MODAL AGE	NORWEGIAN	ICELANDIC	GERMAN	ENGLISH	SPANISH	TOTAL
1	6	-	37	21	-	64
2	14	-	14	16	5	49
3	11	3	3	10	5	32
4	12	12	-	6	8	38
5	2	10	3	4	7	26
6	3	5	-	2	5	15
7	-	2	3	-	2	7
8	-	4	-	-	8	12
9	-	-	-	1	2	3
10	-	-	-	-	1	1
11	-	-	-	-	1	1
Total	48	36	60	60	44	248
Average Age	2.98	5.08	1.83	2.47	5.42	3.30

Table 3 – Numbers of fish at each modal age, by sample.

Eltink *et al* (2000) proposed that otoliths that achieved the agreement of 80% of readers could be considered for inclusion in a reference set or “Agreed Collection”. The higher criterion of 100% was used in the pre-workshop report, and both are expressed in this report for each exchange set and for the whole set by way of comparison.

4.1 Norwegian set

There were 48 otoliths in this set. A total of 11 readers took part, 3 of them only read 47 otoliths, with the remainder reading every otolith. Readers 3 and 10 did not read sample 60010-1, but the other 9 readers all agreed on an age of 2. Reader 8 did not read sample 95827-29, however 9 of the other 10 readers agreed on age 2. All readers agreed on the age of 14 (29%) of the otoliths.

Agreement with the modal age ranged from 58.3% to 93.8% with an overall agreement of 79.8%. Where readers disagreed with the modal age, there was a definite tendency to underage, except for readers 7 and 8 who showed a strong tendency to overage compared to the modal age.

These were relatively young fish and posed few problems for most readers. The two readers that had the best overall scores for agreement, CVs, bias and APE were those from Norway and Iceland. This is perhaps unsurprising given the samples were from more Northerly latitudes and therefore more familiar to them.

A summary of the Norwegian set results can be seen in Table 4.

COUNTRY	NOR	ENG	SPA	HOL	POR	GER	SCO	IRE	ICE	FRA	DEN	OVERALL
CV	.046	.054	.090	.096	.073	.063	.093	.113	.046	.090	.207	.112
% agreement	93.8	91.7	61.7	81.3	83.3	89.6	87.5	74.5	93.8	61.7	58.3	79.8
Relative Bias	0.06	0.04	-0.38	-0.17	-0.17	-0.06	0.13	0.26	0.06	-0.38	-0.06	-0.06
APE	1.7	2.3	9.8	5.3	4.1	2.6	4.0	8.2	1.7	9.8	18.9	-
Overall Rank	1	3	8	7	5	4	5	8	1	8	11	-

Table 4 – Summary of Norwegian Set results

Modal Age	No. with 80% agreement	No. with 100% agreement
1	6	3
2	14	9
3	4	2
4	1	-
5	1	-
6	1	-
Total	27	14

Table 5 – Agreed age collection images

4.2 Icelandic Set

Although 40 images were presented as part of this set, the results only account for 36 of them. The other 4 were all modal age zero, and the software gives a divide by zero error. This will be corrected in an updated version of the software. As all readers gave the age as zero in any case, there should be no effect to the results. It was interesting to note that these fish (19 and 20 cm), grew incredibly quickly for Northern waters. As fish in the North probably do not spawn until May-June and these fish were caught in October, they were 19-20 cm at just 4 months old, which is a questionable result.

A summary of the results of the Icelandic set can be seen in Table 6. As previously explained, only 9 readers read this set and of those, the reader from Portugal was unable to give an age for 2 fish. The results of this set were not as good as for other sets. Agreement ranged from 38.2% to 80.6% with overall agreement at 58.1%. This is better than the pre-workshop exchange. Only 2 readers showed low bias scores, the others were a mix of over and under ageing.

In this set, there was only 1 fish (Ice_003) where all readers were agreed on the age – that of 5 years old (Table 7).

COUNTRY	NOR	ENG	SPA	HOL	POR	GER	SCO	IRE	ICE	FRA	DEN	OVERALL
CV	-	.157	.136	.138	.140	.118	.120	.123	.095	-	.183	.139
% agreement	-	58.3	52.8	52.8	38.2	61.1	66.7	80.6	58.3	-	52.8	58.1
Relative Bias	-	0.56	-0.39	-0.78	-0.68	0.19	0.39	0.03	0.31	-	-0.31	-0.07
APE	-	13.1	10.2	13.2	13.7	10.1	9.7	6.1	9.3	-	11.8	-
Overall Rank	-	7	5	8	9	2	4	1	2	-	6	-

Table 6 – Summary of Icelandic Set results

Modal Age	No. with 80% agreement	No. with 100% agreement
3	-	-
4	1	-
5	2	1
6	-	-
7	-	-
8	-	-
Total	3	1

Table 7 – Agreed age collection images

4.3 German Set

As mentioned above, the German set was of low average age (1.83 years). This may be one reason why the highest agreement rate was achieved for this set – with an overall agreement rate of 94.1%. Many of the readers commented on how good the images were for this set, which may have added to the confidence levels. Individual readers achieved from 90.0%-98.3% agreement with the modal age - an extremely good result for any exchange. A summary of the results for this set is given in Table 8.

There were 60 images in this set, all of which were aged by 10 readers, with one reader unable to give an age for 3 fish. In total, 49 of the 60 images had the complete agreement of all readers (see Table 9). Most of these were aged 1 or 2, but WH324-2 was aged as a 5 year old by all readers.

Country	Nor	Eng	Spa	Hol	Por	Ger	SCO	Ire	Ice	Fra	Den	Overall
CV	.039	.044	.044	.012	.034	.012	.004	.046	.062	.016	.169	.034
% agreement	95.0	90.0	91.7	93.3	94.7	91.7	98.3	95.0	96.7	95.0	93.3	94.1
Relative Bias	0.05	-0.12	-0.08	-0.10	-0.05	-0.12	-0.02	0.02	0.05	-0.08	0.03	-0.04
APE	1.4	2.5	2.0	1.5	1.4	1.9	.02	1.7	1.9	1.3	4.4	-
Overall Rank	3	11	10	6	4	8	1	4	7	2	9	-

Table 8 – Summary of the German Set results

Modal Age	No. with 80% agreement	No. with 100% agreement
1	37	35
2	13	11
3	3	2
4	-	-
5	1	1
6	-	-
7	-	-
Total	54	49

Table 9 – Agreed age collection images

4.4 English Set

The English exchange set had 60 images. All 11 readers attempted them, with 8 readers giving an age for all images. One reader was unable to age 1 image, one reader was unable to age 2 images and one reader was unable to age 3 images. The agreement with the modal age ranged from 64.9% to 91.5% with an overall agreement of 79.2%. Three readers all achieved 80% agreement. A summary of the results of the English set can be seen in Table 10.

A total of 15 out of the 60 otoliths had a modal age which was agreed by all readers (Table 11).

The bias scores for most readers were low, with only the 3 readers achieving the lowest agreement having significant bias scores. Average Percent Error (APE) values were significantly higher than the Norwegian and German sets.

The average age of the samples was again relatively low, with 47 of the 60 images having a modal age of 1-3 years.

Country	Nor	Eng	Spa	Hol	Por	Ger	Sco	Ire	Ice	Fra	Den	Overall
CV	.107	.211	.127	.104	.137	.214	.231	.271	.345	.243	.234	.185
% agreement	91.5	83.3	86.7	78.3	64.9	80.0	80.0	67.2	83.3	80.0	75.0	79.2
Relative Bias	0.05	-0.03	-0.05	-0.17	-0.53	-0.02	0.20	0.40	0.33	-0.02	0.18	0.03
APE	4.0	7.6	5.3	6.1	14.6	9.2	10.8	25.1	14.1	10.5	16.8	-
Overall Rank	1	3	2	4	10	4	7	11	8	6	9	-

Table 10 – Summary of the English set results.

Modal Age	No. with 80% agreement	No. with 100% agreement
1	19	6
2	11	7
3	3	-
4	1	1
5	1	1
6	-	-
7	-	-
8	-	-
9	-	-
Total	35	15

Table 11 – Agreed age collection images

4.5 Spanish Set

The Spanish exchange set consisted of 44 otolith images. Nine readers aged them; one reader did not have the time to complete the readings in time for the report to be written and one reader found that they could not establish an age for any of them. Of the nine readers, seven read all the images, one reader could not age one of the images and one reader could not age seven of the images.

The agreement rate with the modal age ranged from 59.1% to 84.1% with the overall agreement rate at 70.6%. The reader who came out top of the overall rankings was the Spanish reader, which again may reflect familiarity with the stock. A summary of the results for the Spanish set can be seen in Table 12.

Only four images achieved agreement of the age from all readers, but one of these (SS 25.01.2010.N18(4x)IEO) had an agreed age of 8 years old (see Table 13).

As shown in Table 3, the Spanish set had the highest average age of all the exchange sets, so the agreement rates are high and promising.

Country	Nor	Eng	Spa	Hol	Por	Ger	Sco	Ire	Ice	Fra	Den	Overall
CV	-	.043	.066	.145	.121	.097	.111	.106	.090	-	.095	.114
% agreement	-	84.1	84.1	63.6	62.2	69.8	61.4	59.1	72.7	-	77.3	70.6
Relative Bias	-	-0.23	-0.05	-0.07	-0.22	0.07	0.25	0.23	0.14	-	-0.05	0.01
APE	-	3.6	3.4	10.6	8.6	7.9	9.8	8.8	5.5	-	5.8	-
Overall Rank	-	2	1	6	6	5	9	8	4	-	3	-

Table 12 – Summary of the Spanish set results.

Modal Age	No. with 80% agreement	No. with 100% agreement
2	2	-
3	3	2
4	3	-
5	2	-
6	1	1
7	1	-
8	2	1
9	-	-
10	-	-
11	-	-
Total	14	4

Table 13 – Agreed age collection images

4.6 Full exchange set

As two of the 11 readers did not read the two sets of otoliths that proved to be the most difficult to obtain agreement, the results for these two readers are omitted from the analysis of the whole set as this would introduce bias. The small number of images not read by some of the other readers is less problematical at this level, so they will be ignored. A summary of the results for the full exchange set can be seen in Table 14.

There were 248 images of otoliths in the full exchange set. Only five readers aged every image; those from England, Holland, Scotland, Iceland and Denmark. The Spanish and German readers did not age 1 image, the Irish reader did not age 3 images and the Portuguese reader did not age 15 images.

Agreement rates with the modal age ranged from 71.7% to 85.1%. This compares favourably with the pre-workshop exchange (44.9% to 77.4%).

The bias scores show a range from -0.30 to +0.22, with an overall bias of +0.01. Again this compares well to the pre-workshop exchange (-0.59 to +0.45).

Country	Nor	Eng	Spa	Hol	Por	Ger	Sco	Ire	Ice	Fra	Den	Overall
CV	-	.144	.110	.119	.130	.142	.150	.215	.197	-	.226	.116
% agreement	-	85.1	78.9	77.4	71.7	81.8	81.0	73.9	80.2	-	72.2	78.1
Relative Bias	-	0.04	-0.15	-0.20	-0.30	0.02	0.19	0.22	0.20	-	0.01	0.01
APE	-	4.7	5.5	6.3	8.0	5.6	6.4	11.0	6.9	-	12.0	-
Overall Rank	-	1	3	4	8	2	5	9	6	-	7	-

Table 14 – Summary of the full exchange set results.

Modal Age	No. with 80% agreement	No. with 100% agreement
1	62	45
2	36	27
3	13	7
4	6	1
5	7	3
6	2	1
7	1	-
8	2	1
9	-	-
10	-	-
11	-	-
Total	129	85

Table 15 – Agreed age collection images (Note: by removing the results of the 2 readers who did not complete the readings, the numbers of fish with 80% agreement decreases by 4 – all 2 year olds. The number with 100% agreement increases by 2).

5 - Confidence levels

Readers were asked to express their confidence level for the age assigned to each otolith on a scale from 1 to 3. A score of 1 indicates no doubt about the age determined, a score of 2 indicates some ambiguity and a score of 3 indicates a difficulty in expressing an age of any kind. Table 16 shows the average confidence level determined for each reader (institute) for each set of otolith images and for the whole set combined. The average confidence level for all readers combined for each set and the whole set combined are also shown.

The Norwegian reader was unable to attempt the Icelandic and Spanish images in time to be included in the results and the French reader was unable to view the Icelandic images in time and so these results are blank. The French reader was unable to determine any ages from the Spanish images, hence an average ranking of 3 for these images.

The results of the confidence levels closely mirror the agreement levels of each set. The German set achieved the highest agreement and had the highest confidence score (lowest value). The Norwegian and English sets rank 2nd and 3rd in both statistics respectively. The Spanish set, however, had higher agreement than the Icelandic set, but lower confidence levels.

Amongst the individual readers, there was also a good correlation between confidence level and agreement rate. Of the 9 readers who read all 5 sets of images, the readers with the 5 highest confidence scores were the 5 readers with the highest agreement levels, although in a slightly different order. The readers with the 4 lowest confidence scores were those with the lowest agreement rates, again in a slightly different order.

Set	Nor	Eng	Spa	Hol	Por	Ger	Sco	Ire	Ice	Fra	Den	Overall
German	1.067	1.100	1.117	1.250	1.217	1.117	1.100	1.133	1.083	1.100	2.000	1.208
Norwegian	1.053	1.105	1.421	1.526	1.105	1.053	1.053	1.421	1.105	1.263	2.000	1.400
English	1.233	1.400	1.350	1.583	1.917	1.300	1.133	1.800	1.317	1.750	2.000	1.526
Icelandic	-	1.825	1.550	1.975	2.000	1.475	1.325	1.925	1.275	-	1.750	1.678
Spanish	-	1.977	1.545	2.500	2.209	1.750	1.614	2.000	1.295	3.000	1.705	1.959
Total	1.125	1.496	1.353	1.742	1.753	1.349	1.230	1.687	1.210	1.698	1.909	1.514

Table 16 – Average confidence levels expressed by each reader for each set of exchange otoliths.

6 - Summary

The post-workshop exchange was completed in a very timely fashion and produced very encouraging results. Percentage agreement increased against the pre-workshop exchange, CVs decreased and the number of otoliths with total agreement vastly increased. Some of this improvement is no doubt attributable to the reduced number of readers (11 readers as opposed to 15), but much of the increase looks certain to be due to the newly established age determination criteria and the benefit of the discussions of images at the workshop.

A set of Agreed Age images can now be assembled that can contain 129 images (Table 15). This is a good start but some more work is needed to ensure that full coverage of the mackerel distribution area is achieved in the agreed age collection.

Each reader shows differing tendencies to either under or overage compared to the modal age. The readers from Spain, Holland, Portugal and France show a distinct pattern to underage compared with the modal age. The readers from Scotland, Iceland, Ireland and Norway show a tendency to overage compared to the modal age. The readers from England, Germany and Denmark had a more balanced distribution. The results of the reader age against modal age distributions can be seen in Table 17.

Reader	Difference from modal age											Total Readings	Total differences
	-5	-4	-3	-2	-1	0	1	2	3	4	5		
England			1		16	211	16	2	1		1	248	37
Spain				3	40	195	8	1				247	52
Holland		3	3	6	31	192	12		1			248	56
Portugal			2	9	50	167	5					233	66
Germany				1	21	202	19	4				247	45
Scotland					5	201	34	5	3			248	47
Ireland				1	8	181	49	3	2	1		245	64
Iceland					6	199	34	7	1	1		248	49
Denmark				3	33	179	28	2	2	1		248	69
Norway				2		149	17					149	19
France					27	134	5	1				167	33

Table 17 – Differences against modal age by reader