

Evaluating assumptions behind design-based estimators for unreported catches

Thomas L. Clegg^{*}, Edvin Fuglebakk, Kotaro Ono

Institute of Marine Research/Havforskningsinstituttet, Postboks 1870 Nordnes, NO-5817 Bergen, Norway

ARTICLE INFO

Handled by A.E. Punt

Keywords:

Unreported catches
Design-based estimators
Reference fleet
Cluster
Self-sampling

ABSTRACT

Understanding a fishery's impact on the marine ecosystem requires a quantification of total catches, which include unreported catches. For recent years in Norwegian waters, unreported catches have been estimated using data collected by the Norwegian Reference Fleet, a fisher self-sampling programme that regularly gathers data on catches of all species (including unwanted bycatches and discards). In this study, we focused on the use of design-based estimators for total catches in offshore fisheries, which have previously been used to estimate discards in the Norwegian coastal gillnet fisheries. After adapting the current methodology to the data available in offshore fisheries, we explored the assumptions behind both unit- and ratio-based estimators, and the effect of ignoring the cluster sampling design. Using a jack-knife resampling method to estimate the true bias in estimates of total catches and associated variability, we found that ignoring the cluster sampling design tended to underestimate the variability, which lead to occurrences where unreported catches were statistically detected when in fact there was too much uncertainty to make such a conclusion. Further validations suggested the cluster unit estimator is not unbiased as theoretically expected due to the sampling design favouring the selection of more active vessels. We therefore concluded that the unit and ratio cluster estimators are applied and compared, as per best practices.

1. Introduction

Unwanted catches are an inevitable consequence of selective fishing. Increased avoidance or utilisation may alleviate the issue (Karp et al., 2019), but no fishing gear is perfectly selective and the targeting of highly valuable species incentivises discarding of low value catches (Batsleer et al., 2015). A discard ban is a central part of fisheries policy aimed at reducing unwanted catches in selective fisheries, which is typically accompanied by a landing obligation. Ensuring that all catches are landed and reported improves an understanding of the environmental impacts of fisheries. However, even with relatively high compliance rates (Gezelius, 2006; Hønneland, 2000), there are still sources of unreported catches (Box 1) that should be accounted for.

Since 1987 when a discard ban was introduced in Norway, a broad range of technical measures have been added to improve selectivity and encourage full utilisation in fisheries (Gullestad et al., 2015). Snapshot studies and historical reconstructions of unreported catches have found that discards have decreased since the introduction of the discard ban (Dingsør, 2001; McBride and Fotland, 1996; Nedreaas et al., 2015), a trend also supported by the improved status of many commercially

important fish stocks over the decades (Diamond and Beukers-Stewart, 2011; Gullestad et al., 2014). Unreported catches in Norwegian fisheries are therefore assumed to be negligible in many case studies (Gilman et al., 2020; ICES, 2021; Kelleher, 2005; Pérez Roda et al., 2019) despite the acknowledgement that discarding still occurs in Norwegian waters, and that current levels of misreported catches are mostly unknown (Gezelius, 2006; Gullestad et al., 2015; Nedreaas et al., 2015).

In recent years, unreported catches have been estimated in Norway using data collected by the Norwegian Reference Fleet, a group of active fishing vessels trained and paid to self-sample their catches (Clegg and Williams, 2020). Coastal vessels participating in the Norwegian Reference Fleet record discards explicitly, allowing for estimates of bycatches and discards of all species in coastal gillnet fisheries (fish: Berg et al., 2022; Berg and Nedreaas, 2020; seabirds: Fangel et al., 2015; Bærum et al., 2019; marine mammals: Moan, 2016; Moan et al., 2020). However, current routines have not yet been adapted to offshore fisheries where the Norwegian Reference Fleet do not explicitly record discards, but instead report total catches (Box 1).

The Norwegian Reference Fleet programme has a complex sampling design to account for the voluntary, long-term participation of vessels,

^{*} Corresponding author.

E-mail address: tom.clegg@hi.no (T.L. Clegg).

<https://doi.org/10.1016/j.fishres.2023.106686>

Received 14 November 2022; Received in revised form 6 March 2023; Accepted 7 March 2023

Available online 13 March 2023

0165-7836/© 2023 The Author(s). Published by Elsevier B.V. This is an open access article under the CC BY license (<http://creativecommons.org/licenses/by/4.0/>).

multiple sampling objectives, and practical constraints of at-sea sampling. Of specific focus in this study is the cluster sampling design typical of vessel-based sampling. This involves sampling repeatedly from a fixed selection of vessels, such that samples within vessels are more similar to those between vessels. Simple estimators ignore this variation between vessels and can therefore have large impacts on both the bias and precision of estimates (Lohr, 2010; Nelson, 2014), which increases the risk of incorrectly concluding that unreported catches are significantly high. The representativeness of a non-random vessel selection is statistically unknown, but can be inferred through sampling theory and by evaluating estimator assumptions.

This study aims to evaluate the performance of estimators for total catches in Norwegian fisheries, using the Barents Sea longline fishery as a case study. After presenting a new estimation framework, we evaluated estimator performance using three objectives:

- 1) Quantify estimator bias by evaluating the statistical assumptions behind the simple estimators currently used for unreported catches (Bærum et al., 2019; Berg and Nedreaas, 2020; Fangel et al., 2015) and equivalent cluster estimators.
- 2) Assess representativeness by exploring how non-random sampling impacts estimator assumptions and therefore estimator bias.
- 3) Using selected species, explore how estimator bias and representativeness impacts the ability to detect unreported catches and make actionable advice.

2. Material and methods

2.1. Case study fishery and species

The Barents Sea longline fishery is defined in this study as vessels over 28 m overall length operating in the statistical areas shown in Fig. 1. The fishery operates over almost the entire Barents Sea, but we restrict our study to the statistical areas where vessels are most active. The fishery operates year-round but is restricted in northern areas in winter months by expanding sea ice cover. Vessels predominantly target cod (*Gadus morhua*) and haddock (*Melanogrammus aeglefinus*), but also target a wide range of other demersal fish species, notably tusk (*Brosme brosme*), Greenland halibut (*Reinhardtius hippoglossoides*), and wolffish (*Anarhichas* spp.).

A total of 50 fish species or species groups were observed by the Norwegian Reference Fleet in the Barents Sea longline fishery (See [Supplementary Materials](#) for full list). We assumed that all unidentified redfish species (genus: *Sebastes*; 0.5 % of total sampled weight) were lesser redfish (*Sebastes viviparus*), given that other two redfish species (*Sebastes mentella* and *Sebastes norvegicus*) are commercial species which are more easily identifiable by fishers. Where species groups are reported in official catch statistics, we estimated total catches for individual species in that group, which can then be aggregated to the desired taxonomic level for comparison with reported catches. For skates and

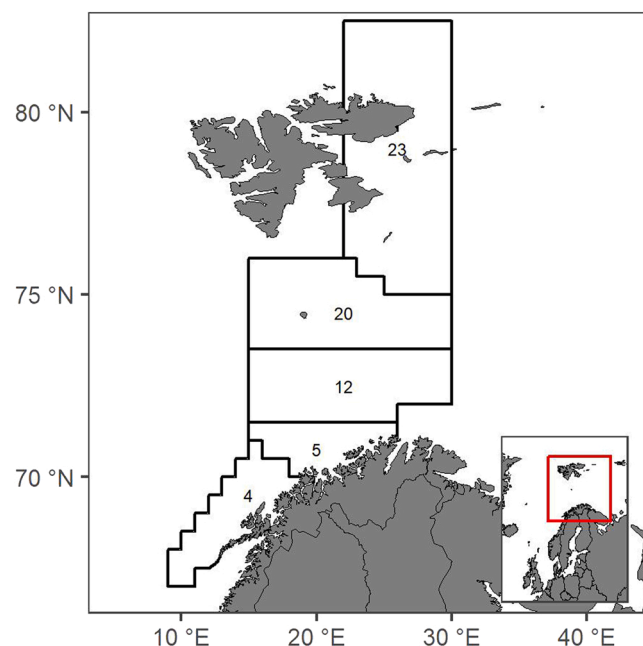

Fig. 1. Statistical areas in the Barents Sea longline fishery as defined by the Norwegian Directorate of Fisheries.

rays (order: Rajiformes), we removed 121 observations which were not identified to the species level. This removal reduces the sample size for skate and ray species but allows us to estimate unreported catches for individual species. Extremely large catches of species were identified and removed manually using expert knowledge if there was no verification.

2.2. Data

We used three datasets in this study. The Norwegian Reference Fleet provides observations of total catches for all species. After estimating average total catches for sampled vessels, we extrapolated these to the entire fishery using information on fishing activity from mandatory daily logbooks (Electronic Reporting System). Then to infer unreported catches, we compared total catch estimates with official catch statistics derived from sales notes.

2.2.1. Norwegian Reference Fleet

Vessel selection in the Norwegian Reference Fleet is required by law to follow a public tender process, which lists required and desired criteria that a vessel must meet to be eligible for participation. An expert panel reviews the applications to produce a shortlist of eligible vessels to which the contract is randomly awarded. The tender specifications and

Box 1

Definitions of catch categories referred to in this study.

Total catch The biomass of marine resources that are brought on board the vessel.

Landings or retained catch The retained portion of total catches that is landed and reported through mandatory channels.

Discards That portion of the total catch which is thrown away or dumped at sea before landing for whatever reason. Includes incidental catches (e.g., marine mammals and seabirds) but not shells, corals, plants, or inorganic materials, nor processing waste such as offal and carcasses.

Bycatch The portion of catch of non-target species, which can either be landed or discarded.

Unreported catches The portion of total catches that are not explicitly reported to species level in official statistics. Unreported catches comprise of discards, illegal catches, and unmandated catches (Pitcher et al., 2002).

expert judgement selection process aims to simulate a stratified random sample of vessels from the fishery with respect to gear types, vessel characteristics, and fishing activity.

Vessels sample total catches for one fishing operation every two days, known as a 1-in-2 systematic sample. A systematic sample is expected to behave like a simple random sample (Lohr, 2010), and has been validated for the Norwegian Reference Fleet in the context of reported catches (Clegg et al., 2022). On each sampling day, total catches are recorded from three representative samples of consecutive hooks that are taken from the start, middle, and end of longlines. This selection is made by the crew or skipper who deem it representative of the catch composition for that day. Therefore, total catches per day are extrapolated using the ratio of total and sampled hooks. There is an agreement between fishers, scientists, and the Norwegian authorities that data collected by the Norwegian Reference Fleet shall not be used for prosecution. This agreement has not been compromised in the 20 year history of the programme, providing a trustful incentive for fishers to report total catches honestly.

We used 2 116 observed fishing days from six vessels between 2012 and 2018, which equates to almost 10 % of all fishing days from 14 % of vessels in the fishery (Table 1). Total hooks could not be determined for 67 sampled fishing days (3 %), due to either erroneous misreporting or sampling over midnight such that dates did not match. We imputed these values with the modal number of hooks used by that vessel in the study period.

2.2.2. Daily logbooks (Electronic Reporting System)

In the Barents Sea, Norwegian fishing vessels longer than 15 m overall length are required to keep a daily logbook of catches and fishing activity using an electronic reporting system. A catch report must be sent at least once per calendar day and is required for each fishing operation (defined as the period from the fishing gear entering the water until it is taken out of the water). However, it is more difficult to define discrete fishing operations for passive gears like longlines, so catch reports and fishing effort (number of hooks) are typically sent as a single daily summary.

Logbooks were provided by the Norwegian Directorate of Fisheries. We used them as a measure of fishing effort for all fishing days by vessels in the Barents Sea longline fishery, which equates to 23 100 logbook entries. Vessels typically set tens of thousands of hooks each day, but can sometimes set longlines in the order of thousands of hooks for experimental fishing. However, we deemed entries with fewer than 1000 hooks as erroneous (n = 231), and therefore imputed the number of hooks used as the modal value for that vessel in the study period.

Skippers are required to maintain an up-to-date estimate of all catches from each fishing operation. However, as logbooks are used for control and enforcement purposes, they only contain the retained portion of catches. Reported catch weights at sea are estimated, as the official reporting of catches is done on land with verifiable equipment. Furthermore, species reporting at sea is not as strict as upon landing, meaning many species are often grouped. Due to these uncertainties in reported catch estimates, we concluded that logbooks are not a reliable

Table 1

Summary of sampling by the Norwegian Reference Fleet sampling programme in the Barents Sea longline fishery. The summary across all years is not the sum of individual years because vessels are active over multiple years.

| Year | Vessels | | | Fishing days | | |
|-----------|---------|------------|-------------------|--------------|------------|-------------------|
| | Sample | Population | Sampling fraction | Sample | Population | Sampling fraction |
| 2012 | 6 | 36 | 0.17 | 758 | 4 943 | 0.150 |
| 2013 | 5 | 34 | 0.15 | 320 | 3 471 | 0.092 |
| 2014 | 6 | 27 | 0.22 | 224 | 2 998 | 0.075 |
| 2015 | 4 | 27 | 0.15 | 176 | 2 698 | 0.065 |
| 2016 | 4 | 28 | 0.14 | 206 | 3 172 | 0.065 |
| 2017 | 4 | 26 | 0.15 | 158 | 2 866 | 0.055 |
| 2018 | 4 | 28 | 0.14 | 274 | 2 952 | 0.093 |
| All years | 6 | 42 | 0.14 | 2 116 | 23 100 | 0.092 |

source of reported catches for comparison with estimated total catches.

2.2.3. Sales notes

All first-hand sales of fish are directed through one of six sales organisations in Norway (reduced to five in 2020). Upon landing, a sales note must be immediately sent to the sales organisation to receive payment for catches. These sales notes are also sent to the Norwegian Directorate of Fisheries as the official record of catches, who provided them for this study. Reported weights are recorded using officially approved scales, and the sales note is signed by both buyer and seller to reduce the opportunity for fraudulent reporting. The sales organisations are responsible for confiscating illegal catches, monitoring quota, and reporting vessels in breach of fisheries law. Sales organisations are subject to on-site or data inspection at any time. This centralised system provides the most reliable data source on reported catches, which we deducted from estimated total catches to infer the magnitude of unreported catches.

Reported weights of fish are recorded after any processing on board, and therefore require conversion back into the round weight (live weight when removed from the water). Conversion factors are intermittently published as annual mean values for all statistical areas (Norwegian Directorate of Fisheries, 2021). Due to the difficulties in quantifying uncertainties in conversion factors for all species and products, we assumed reported landings are known without error.

2.3. Standard estimation framework

Samples from the Norwegian Reference Fleet were post-stratified using a combination of year, statistical area (Fig. 1), and season

Table 2

Candidate estimators for unreported catches using Norwegian Reference Fleet data. Estimators were applied to individual post-strata, defined as year, statistical area (Fig. 1), and annual quarter. See Table 3 for notation in formulae.

| Estimator | Equation | Assumptions |
|-----------|---|--|
| Simple | | |
| Unit | $\hat{Y} = \frac{M}{m} \sum_{j=1}^M y_j$ (1) | <ul style="list-style-type: none"> Primary sampling unit = fishing day Observations are a simple random sample of all fishing days |
| Ratio | $\hat{Y} = X \frac{\sum_{j=1}^m y_j}{\sum_{j=1}^m x_j}$ (2) | <ul style="list-style-type: none"> Ratio: strong correlation between total catches (y_j) and fishing effort (x_j) for individual fishing operations |
| Cluster | | |
| Unit | $\hat{y}_i = \frac{M_i}{m_i} \sum_{j=1}^{m_i} y_{ij}$ (3.1) | <ul style="list-style-type: none"> Primary sampling unit = vessel Secondary sampling unit = fishing day |
| | $\hat{Y} = \frac{N}{n} \sum_{i=1}^n \hat{y}_i$ (3.2) | <ul style="list-style-type: none"> Observed vessels are a simple random sample from all vessels. |
| Ratio | $\hat{y}_i = \frac{X_i}{x_i} \sum_{j=1}^{m_i} y_{ij}$ (4.1) | <ul style="list-style-type: none"> Observed fishing days are a simple random sample from each vessel |
| | $\hat{Y} = X \frac{\sum_{i=1}^n \hat{y}_i}{\sum_{i=1}^n X_i}$ (4.2) | <ul style="list-style-type: none"> Ratio: strong correlation between total catches (y_i) and fishing effort (x_i) for individual vessels |

(winter: January-April; summer: May-August; autumn: September-December). The defined estimators for total catches (Table 2) were then applied to each post-stratum individually. All estimators were applied to total catches (i.e., before sorting) because offshore vessels in the Norwegian Reference Fleet only began reporting discarded and retained portions of the catch in 2019. Unreported catches must therefore be inferred by comparison with landed catches reported in sales notes.

The current methodology for estimating discards and bycatches in Norwegian fisheries uses simple estimators (Equations 1 and 2; Table 2), which calculates the average total catch per unit (fishing day) or per effort (hooks), which is then extrapolated to all units or hooks used in the fishery. These estimators assume that fishing operations are a simple random sample from all fishing activity on the level of each post-stratum. Furthermore, the ratio estimator assumes a strong correlation between total catches and fishing effort for individual fishing operations. This correlation is expected to improve precision at the expense of some bias (Lohr, 2010). In the longline fishery, we defined fishing effort as the number of hooks used per calendar day Table 3.

We defined two additional estimators based on cluster sampling, which better reflects the sampling design of the Norwegian Reference Fleet. This method first estimates total catches for each sampled vessel before extrapolating average catch per vessel up to all vessels in the fishery. Vessels are defined as the primary sampling unit, which are assumed to be a simple random sample from the fishing fleet. Fishing days are secondary sampling units which are clustered within vessels, which are assumed to be a simple random sample from all fishing days by each individual vessel.

We defined a post-stratum as unsampled if it had less than three observed fishing days. Total catch rates in unsampled post-strata were imputed by borrowing data from those adjacent which were assumed to have similar rates. We defined a three-tier imputation routine for unsampled post-strata: firstly, observations were taken from the same statistical area and season in the adjacent years (for 2012 and 2018 – the first and last year in the study – this meant only one adjacent year). If there were no observations in adjacent years, we expanded the imputation to include observations from all years in that statistical area and season. If a statistical area was not observed for a given quarter in any years, then we estimated the total catch rate using all observations in the study.

Variability of estimated total catches for species were estimated using the bootstrap method ($B = 5\,000$ replicates) (Efron and Tibshirani, 1994). To estimate the variability of simple estimators, we defined a ‘simple’ bootstrap routine that reflects the estimator assumptions. For each post-stratum, fishing days were resampled with replacement from a single pool including all fishing operations, with a sample size equal to the original dataset. The ‘cluster’ bootstrap routine first resampled vessels with replacement. Fishing days were then post-stratified, and for each post-stratum we resampled fishing days with replacement for each vessel individually. If a bootstrap sample resulted in a post-stratum

Table 3
Notation for Equations in Table 2. Sampled data are collected by the Norwegian Reference Fleet (See Section 2.2.1.); population data are extracted from daily logbooks (see Section 2.2.2.).

| Notation | Sample | Population |
|-----------------------------------|----------------------|----------------------|
| Weight of total catches* | y | Y |
| Fishing effort (number of hooks) | x | X |
| Number of vessels | n | N |
| Reference to vessel | $i(i = 1, \dots, n)$ | $i(i = 1, \dots, N)$ |
| Number of fishing operations | m | M |
| Reference to fishing operation | $j(j = 1, \dots, m)$ | $j(j = 1, \dots, M)$ |
| Reference to jack-knife replicate | $k(k = 1, \dots, K)$ | |
| Reference to bootstrap replicate | $b(b = 1, \dots, B)$ | |

* Estimated sample and population totals denoted as \hat{y} and \hat{Y} respectively

being unsampled, then we used the imputation routine described in the previous paragraph. We used bootstrap replicates to calculate 95 % confidence intervals using the percentile method. If reported catches fell outside the confidence interval of estimated total catches, we considered unreported catches to be statistically detected.

2.4. Quantifying estimator bias

A typical validation of estimator performance (bias and precision) involves identifying a domain with a true value with which to compare estimates. However, this is not possible for fishery-level estimates of unreported catches. Only observations of total catches are available, from which the unreported portion must be inferred. Even considering observed total catches, a bias assessment is complicated by the sub-sampling of hooks which means we are not even certain of total catches for any sampling unit (vessels or fishing days). Finally, for post-strata in which only one vessel was sampled, removing that vessel would result in no observations.

We defined our domain for testing biases using the only data available for which we can assume are true: total annual catches by Norwegian Reference Fleet vessels in post-strata in which two or more vessels were sampled (Y^*). This testing domain involves firstly extrapolating sampled hooks to the day-level, and secondly to the vessel-level for each post-stratum before being summed over all vessels and strata within each year. This first extrapolation step is a typical necessity where sampling of large fishing operations is unfeasible. The second step is necessary such that the ‘truth’ is defined at the level of primary sampling units (vessels), which then allows for resampling of secondary sampling units (fishing days). Sub-sampling of fishing operations is common and extrapolations are often done on-board to estimate the haul-level catches (e.g., Borges et al., 2005). The extrapolation to vessel-level catches per post-strata is also assumed to introduce negligible bias due to the robust systematic sampling routines for fishing operations for each vessel (Clegg et al., 2022). Limiting post-strata to those with two or more sampled vessels avoids imputation of under-sampled post-strata, which will introduce additional biases. Given that this testing is limited to sampling data, the evaluation focuses on estimator biases by excluding selection biases which relate to the representativeness of samples.

To evaluate estimator biases in the defined domain, we used a jack-knife resampling method (Fig. 2). For each year, a single vessel was randomly removed from the dataset. Then, fishing days were resampled randomly with replacement for each vessel and post-stratum. This resampled dataset (k) was then used to re-estimate total sampled catches (\hat{Y}_k^*) for each species using the estimators defined in Table 2. The jack-knife resampling process was repeated $K = 5\,000$ times. which we

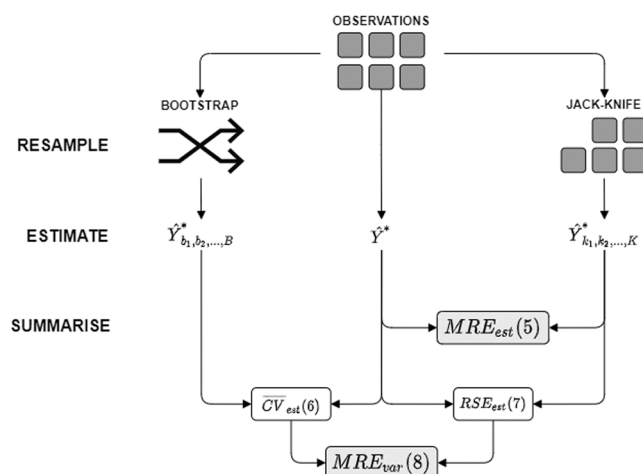

Fig. 2. Schematic of bias evaluation. Equations numbers given in brackets.

deemed sufficient to approximate an equal number of removals for all vessels, given the removals were random instead of systematic for each replicate. Total catches were also estimated for the testing domain dataset using the bootstrap method (\hat{Y}_b^* ; see standard estimation framework section), using $B = 5\,000$ bootstrap replicates.

$$MRE_{est} = \frac{1}{Y^*K} \sum_{k=1}^K (\hat{Y}_k^* - Y^*) \quad (5)$$

$$\overline{CV}_{est} = \frac{1}{Y^*} \sqrt{\frac{1}{B-1} \sum_{b=1}^B (\hat{Y}_b^* - Y^*)^2} \quad (6)$$

$$RSE_{est} = \frac{1}{Y^*} \sqrt{\frac{1}{K-1} \sum_{k=1}^K (\hat{Y}_k^* - Y^*)^2} \quad (7)$$

$$MRE_{var} = \frac{\overline{CV}_{est} - RSE_{est}}{RSE_{est}} \quad (8)$$

Biases in the design-based estimators (Table 2) and associated variability were calculated by comparing the jack-knife estimates with the truths we have defined as followed:

- Bias in each design-based estimator was calculated using Eq. 5, defined as the mean relative error of jack-knife estimates (MRE_{est} ; Fig. 2).
- Bias in the variability of each design-based estimator was calculated using Eq. 8, which compares the estimated coefficient of variation (Eq. 6) with the true relative error (Eq. 7) which we assumed using the jack-knife method.

The cluster unit estimator is theoretically unbiased given random sampling (Lohr, 2010). However, due to the low number of vessels in our dataset, we expected some deviation from zero for even an unbiased estimator, as we cannot simulate enough sampling variation to approximate a continuous distribution.

The bias in both the estimate (Eq. 5) and associated variability (Eq. 8) were compared across all four estimators (Table 2) for each species and year to get a generalised overview of estimator performance and more specifically determine the importance of accounting for the cluster sampling design. Based on this analysis, we focused the rest of the analysis on the cluster estimators.

To investigate how biases varied across the 50 species observed in this study, we then plotted the estimated bias (Eq. 5) and variance (Eq. 6) of the cluster estimators against the encounter rate of species in sampled catches. The sampling design of the Norwegian Reference Fleet is generalised for all species, which will result in varied performance of estimators across species, particularly for rare bycatch species (Martin et al., 2005; Pennington, 1996). Viewing the estimator performance across the range of species encounter rates can help to determine if there is a tolerable limit to estimator performance for rare species.

Finally, we evaluated the core assumption of the cluster ratio estimator: It assumes a linear relationship between total catches and number of hooks. We therefore calculated the Pearson's correlation coefficient (ρ) for each species and year then plotted against the bias (MRE_{est} ; Eq. 5) and variance (RSE_{est} ; Eq. 7) of the cluster ratio estimator.

Note that here we are comparing jack-knife estimates to the total observed catch reported by the reference fleet, not the total landings from the entire fleet. This allows us to treat concerns about clustering and bias in ratio estimation separate from concerns about pragmatism in sample selection that are not explicitly accounted for by the estimators.

2.5. Assessing the representativeness of samples

The jack-knife resampling method addresses estimator biases but

cannot account for selection biases which affect the representativeness of samples. Therefore, we evaluated the representativeness of samples using the best practice method of comparing fishing effort characteristics between samples and the population (ICES, 2007, 2003), using data from daily logbooks. We compared total annual fishing days per vessel, for which the cluster unit estimator assumes samples are representative. Unequal fishing days per vessel also indicates that a ratio estimator is more appropriate. We also compared annual mean number of hooks per vessel, which influences the precision of ratio estimators.

2.6. Exploring the chosen estimators

The statistical analyses described above were used to define the best estimators for unreported catches across all species. We explored how the chosen estimation procedure affected the detection of unreported catches for three commercially important species in the Barents Sea longline fishery: cod, haddock, and beaked redfish (*Sebastes mentella*), to demonstrate how the sensitivity of statistical detection could influence the ability to make actionable conclusions. Cod and haddock are valuable species for which discards are expected to be negligible (ICES, 2021). Beaked redfish and golden redfish are morphologically similar and have partially overlapping habitats, making landing statistics less reliable (ICES, 2021). Beaked redfish is quota-regulated, whilst golden redfish is only landed using quota set aside for unavoidable bycatches, so the risk of misreporting of these two redfish species are likely interlinked.

3. Results

3.1. Quantifying estimator bias

The jack-knife resampling analysis provides evidence for the importance of accounting for the cluster sampling design when using Norwegian Reference Fleet data to estimate total catches. Using observations in sampled post-strata as the testing domain, we found the cluster unit estimator performed best overall with negligible bias across all species, whilst the cluster ratio estimator had relatively similar bias to both simple estimators (Fig. 3A). Ignoring cluster sampling resulted in an underestimation of variance for almost all species, which improved when applying cluster estimators, albeit with a small tendency to overestimate variance (Fig. 3B).

Whereas the cluster unit estimator is unbiased in all cases, Fig. 4A reveals that the cluster ratio estimator is more biased when applied to rarer bycatch species (i.e., low encounter rate). The cluster ratio and unit estimators have similar trends in precision across the range of encounter rates, apart from the rarest species ($\leq 10\%$ encounter rate) for which the variance is almost twice as large as the mean ($RSE_{est} > 2$). A poor correlation between total catches and number of hooks begins to affect the performance of the cluster ratio estimator below a threshold of $\rho \approx 0.25$ (Fig. 4B), both with regards to bias and precision.

3.2. Assessing the representativeness of samples

Norwegian Reference Fleet vessels are some of the most active vessels in the fishery (Fig. 5), suggesting that samples are not representative of average fishing days per vessel in the fishery. In three out of seven years, the most active vessel has participated in sampling. In addition to a higher number of fishing days, Norwegian Reference Fleet vessels also use more hooks per fishing day than most other longline vessels in the fishery (Fig. 5). This combination of using more hooks over more days will lead to likely lead to an overestimation of catches when applying a cluster unit estimator. Comparatively, the cluster ratio estimator accounts for variable fishing effort, meaning that in this regard, it is more tolerant towards the issues in representativeness identified here.

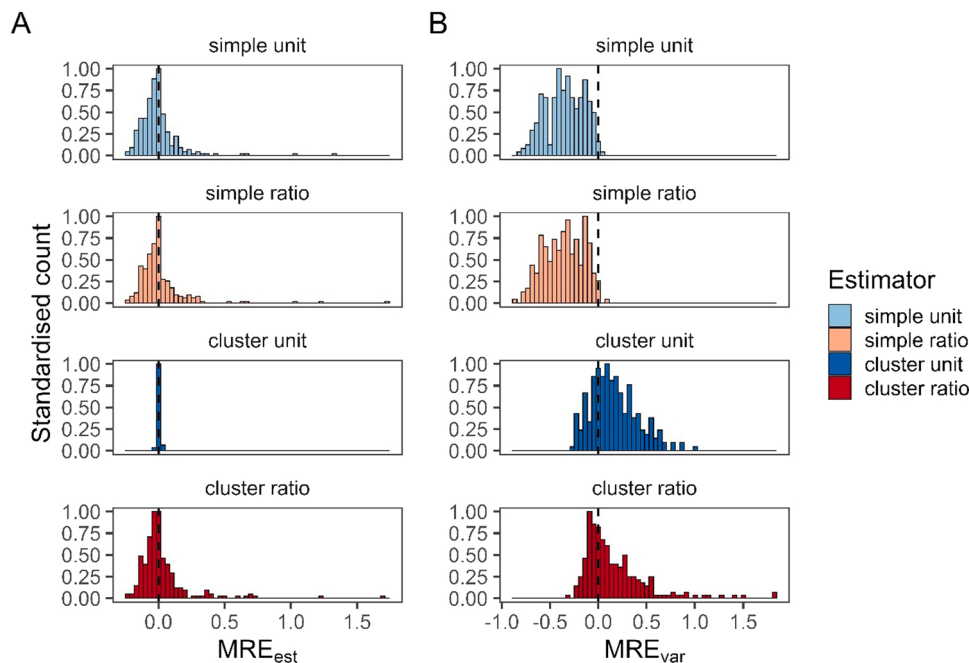

Fig. 3. Performance of estimators using total annual observed catches of species by the Norwegian Reference Fleet. (A) mean relative error of estimate and (B) variance. Scaled counts used to compare across estimators.

3.3. Exploring the chosen estimators

From the evidence presented here, we conclude that the cluster estimators are the best method for estimating unreported catches in Barents Sea longline fishery using data collected by the Norwegian Reference Fleet. The increased uncertainty resulting from accounting for the clustering of data is demonstrated in Fig. 6 for selected species. For cod and haddock, using the cluster ratio estimator does not result in any detected misreporting. In comparison, the simple unit estimator (current standard) detects misreporting in four out of seven years for cod, and five years for haddock. Conversely, underreporting of golden redfish was statistically detected in 2014 and 2015 if the cluster ratio estimator is applied, compared to the cluster unit estimator for which uncertainty is often larger than the reported component of catches. The tendency for the cluster unit estimator to potentially overestimate total catches is not seen to such a large degree with beaked redfish, indicating that vessel-specific fishing behaviour is highly variable across species.

Deciding between the unit and ratio cluster estimators is not as clear of a conclusion. Whilst the cluster unit estimator is unbiased (Fig. 3), the risk of poor representativeness (Fig. 5) means that for some species, the cluster unit estimator may have a tendency to overestimate total catches relative to all other estimators (Fig. 6).

Statistical detection of unreported catches is dependent on the confidence level chosen, which should be considered when interpreting estimates for 50 species. At a 95 % confidence level, there is a 5 % probability that statistically detected unreported catches were a result of chance. Statistical detection of unreported catches is also dependent on the level of aggregation that results are presented. For example, applying the cluster ratio estimator to total unreported catches of haddock in all years combined results in statistically detectable levels of unreported catches (95 % CI: 1 555–20 734 tonnes), even though for individual years, unreported catches are not statistically detectable (Fig. 6).

Final estimates of unreported catches for all species observed in the Barents Sea longline fishery are available in the [Supplementary Materials](#). Total catches of skate and ray species are presented collectively as a species group (order: Rajiformes) to allow for comparison with reported catches, and as a separate file listing estimated total catches for

individual skate and ray species.

4. Discussion

Using a single estimation routine for unreported catches of all species in a fishery promotes simplicity, speed, and comparability (Gilman et al., 2020; Kennelly, 2020; NMFS, 2011). This study demonstrates how a poor understanding of estimation accuracy across species can produce severely misleading results. The importance of accounting for cluster sampling of fisheries is well understood (Aanes and Pennington, 2003; Borges et al., 2005; Fernandes et al., 2021; Lohr, 2010; Nelson, 2014) but is typically ignored due to a lack of awareness (Nelson, 2014). The cluster sampling design of the Norwegian Reference Fleet has only been recognised previously when bycatch rates were estimated using a model-based approach (Bærum et al., 2019; Moan et al., 2020), but ignored when using design-based estimators for reasons of simplicity and a historical focus on point estimates rather than on uncertainty. Bias in simple estimators was identified in a previous study in the Barents Sea longline fishery in the context of reported catches (Clegg et al., 2022). Our study supports this finding by demonstrating that cluster estimators improve both the accuracy of the point estimate and associated uncertainty. For many species, estimates of total annual catches did not improve by accounting for clustering of data, and in most cases led to increases in estimated uncertainty. However, we have demonstrated how simple estimators are at risk of incorrectly detecting unreported catches as a result of underestimating the precision (Fig. 3).

Using encounter rate and Pearson's correlation coefficient between total catches and number of hooks are helpful for evaluating the performance of estimators across many species in a design-based framework. The Pearson's correlation coefficient is a fundamental factor of estimator performance for ratio estimators (Lohr, 2010) and we conclude based on best practices (ICES, 2007) that the use must be supported by evidence of a relationship rather than depending on assumptions. Encounter rates are considered for specific species in the USA's national bycatch reporting system (NMFS, 2011; Wigley et al., 2021) for which encounters are known to be rare. A similar approach is applied in Norwegian fisheries where seabirds (Bærum et al., 2019; Fangel et al., 2015) and marine mammals (Moan et al., 2020) are

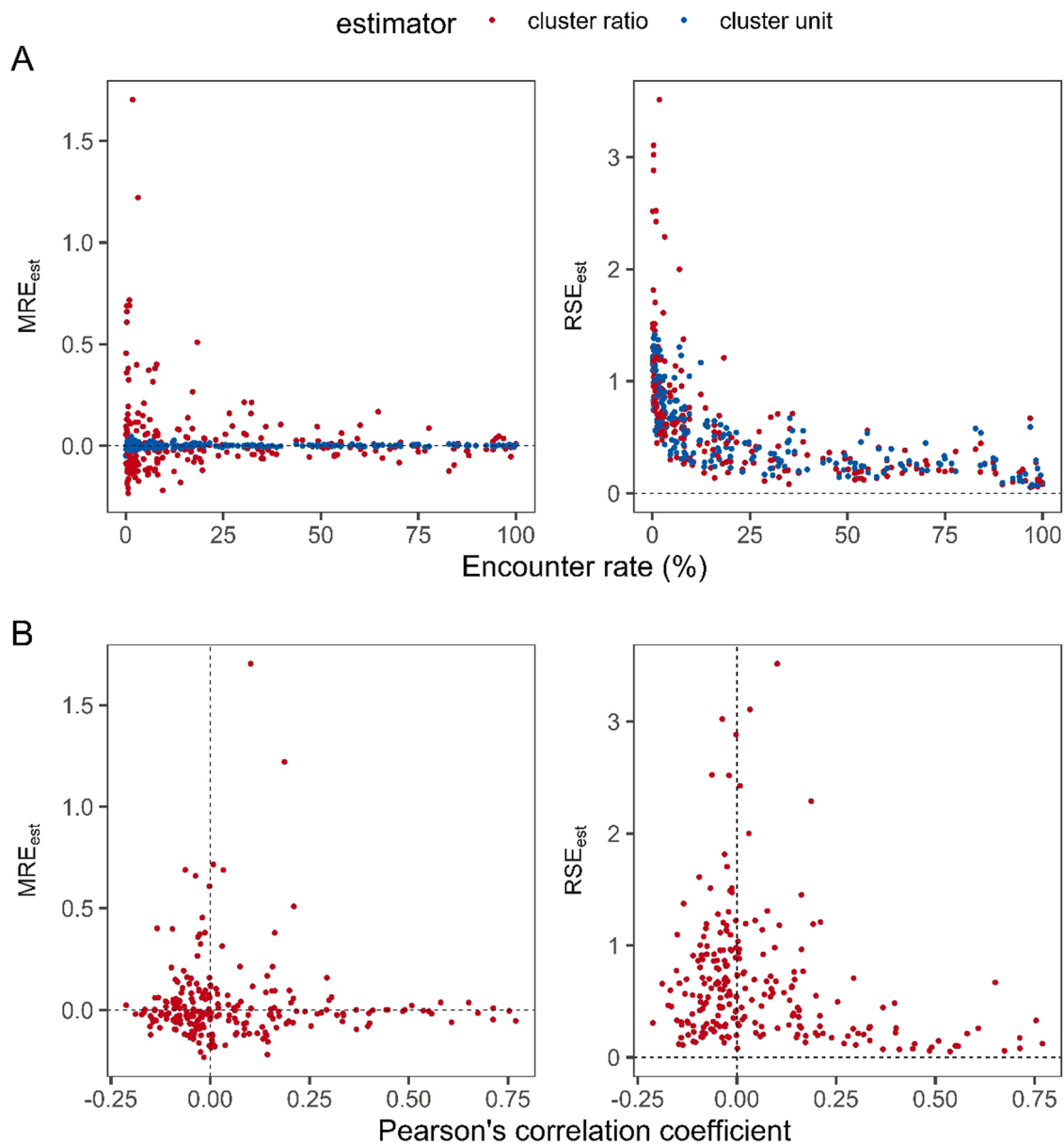

Fig. 4. Effect of (A) encounter rate and (B) correlation between total observed catches and fishing effort on the bias (MRE_{est}) and variance (RSE_{est}) of estimators. Each point represents one species in one year. Testing domain limited to observed fishing days in post-strata where two or more vessels were sampled.

estimated independent to fish species (Berg and Nedreaas, 2020). Estimating incidental bycatches separately is useful to address the sparse observations and unique drivers (e.g., distance from coast influencing seabird bycatches; Bærum et al., 2019). However, with fishes it is not so clear which species should be isolated for individual estimation. We identified that estimators perform poorly when the Pearson's correlation coefficient falls below 0.25, and when rarer species have an encounter rate below 10%. These empirical 'rules of thumb' are useful when many management decisions are made for species from a single estimation study. These findings can also guide future research on improving estimators, as well as to understand if estimator performance can be generalised for other fisheries with Norwegian Reference Fleet sampling.

Representativeness is difficult to quantify in the direct context of unreported catches. It is therefore hard to identify whether the correct detection of unreported catches is driven by sampling biases or sampling rates. However, exploring estimates for commercial species (Fig. 6) shows that estimates are within expected ranges, suggesting a low risk of

extreme sampling biases. Nevertheless, there are issues of representativeness that should be addressed. By evaluating the assumptions behind the estimators applied here, we identified that the cluster unit estimator may not be consistently suitable across species due to a suspected tendency to overestimate total catches. The cluster ratio estimator mitigates against overestimation by accounting for the higher fishing activity of Norwegian Reference Fleet vessels compared to the wider fleet (Fig. 4). Nevertheless, we must still consider if data collected by the Norwegian Reference Fleet are representative of the fishery in terms of fishing strategy and catch composition. This is also relevant to the smaller distribution of fishing effort for sampled vessels than that of the wider fleet (Fig. 5). This is an expected consequence of expert judgement sampling. Since the reference fleet vessels are engaged for several years, it has been preferred over risking an untypical random selection. The application of the ratio estimate can serve to correct for this, to the extent that the catch rates are independent of effort. Although the ratio estimator accounts for the sampling of more active vessels, the sampled catch per unit effort (number of hooks) may still not be representative,

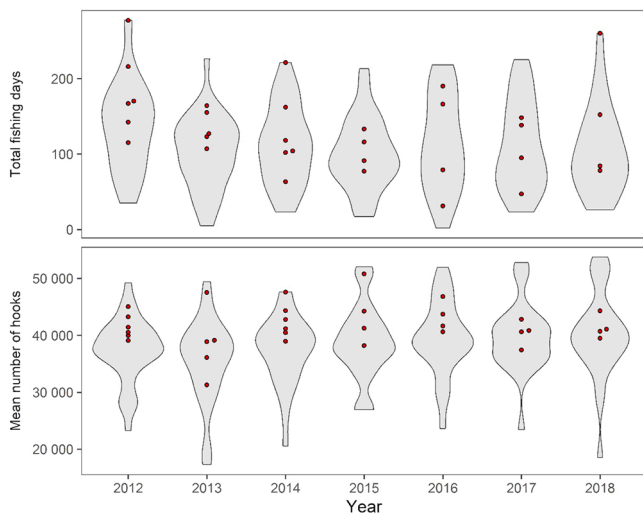

Fig. 5. Distribution of two measures of fishing effort by vessels in the Barents Sea longline fishery. Red points denote position of sampled vessels (Norwegian Reference Fleet) within the distribution. Coinciding points are horizontally jittered to avoid overlapping.

and different fishing strategies may mean sampled catch compositions are not representative. Clegg et al. (2022) found the Norwegian Reference Fleet tended to be representative of the wider fishery in relation to the reported component of total catches, particularly for commercial species, but identified a tendency to overestimate reported catches. This tendency is likely to also be applicable to the unreported component of catches that are estimated in this study. We highlight though that representativeness discussed here is in the specific context of estimating total catches in a fishery. Therefore, any discussion cannot be directly applied to evaluating other contexts of representativeness such as temporal trends in catch per unit effort or estimating fish population parameters.

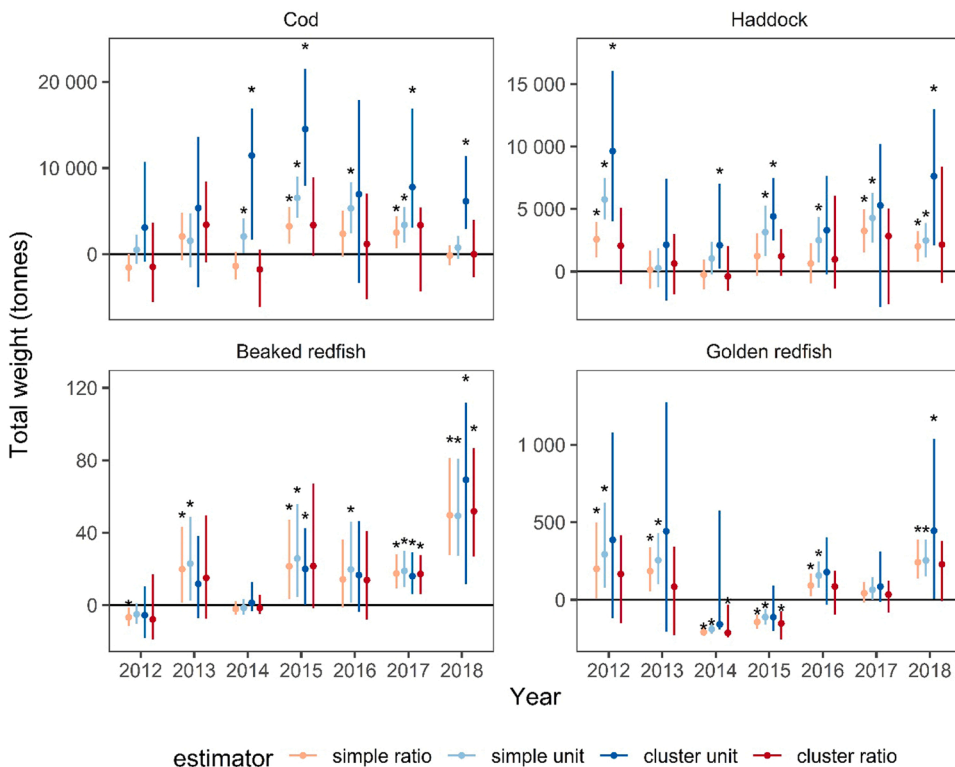

Fig. 6. Estimated unreported catches (difference between estimated total catches and official reported catches; mean and 95 % confidence interval) of cod (*Gadus morhua*), haddock (*Melanogrammus aeglefinus*), beaked redfish (*Sebastes mentella*), and golden redfish (*Sebastes norvegicus*) using the four candidate estimators. Positive values mean under-reporting (estimated total catches > reported catches); negative values mean over-reporting (estimated total catches < reported catches). Asterisk highlights that misreporting has been detected (i.e., reported catches fell outside the confidence interval of estimated total catches).

When estimating unreported catches, there is no specific knowledge on the sources of unreported catches. Unreported catches often suggest illegality caused by either discarding or intentional misreporting of landed catches, but there are many sources of unreported catches that are legal under discard policies. Discard bans typically come with exemptions for non-quota species or high survivability (Borges et al., 2016; Catchpole et al., 2017; Karp et al., 2019). Low resolution reporting also leads to unreported catches. For example, difficulties in species identification of skate and rays (order: Rajiformes) leads catches being landed unidentified. Norwegian vessels are increasingly converting unwanted catches into fishmeal to increase utilisation of catches. However, vessels are not obliged to report the fishmeal ingredients with respect to relative contributions of individual species.

4.1. Improvements

Whilst the Norwegian Reference Fleet form the basis for data on unreported catches, there is scope for enhancing data with other sources. The Norwegian Directorate of Fisheries Monitoring and Surveillance Service (MSS) regularly hire fishing vessels to monitor catch rates in the Barents Sea fisheries. These data were used to map the bycatch risk and estimate historical bycatches of cod in the Barents Sea shrimp fishery (Aldrin et al., 2011; Breivik et al., 2017, 2016). Whilst MSS data have been demonstrated to be suitable for specific case studies, we recommend a devoted study to address representativeness of these data before generalising the application to all fisheries with MSS coverage.

This study has focused on determining the best estimator based on the current estimation framework in Norwegian Fisheries. The current practise for spatial stratification for estimating bycatches and discards in Norwegian fisheries is using statistical areas defined by the Norwegian Directorate of Fisheries. However, this stratification has not yet been optimised. The gridded system likely explains some spatial variations in catches, but more complex drivers of spatial variations in catch composition such as temperature, depth or habitat are poorly described by a gridded statistical area system.

Design-based cluster estimators performed poorest for rare species

(Fig. 4A). Improving estimation accuracy whilst remaining with a design-based framework may involve using the delta lognormal estimator (Pennington, 1996). However, there is wider scope for improvements using model-based tools. On a single species basis, zero-inflated modelling can also improve both the bias and precision of parameter estimates (Martin et al., 2005). In a multispecies context, a wider pool of information on the catch composition may help to explain the variations in catches of rare species by ‘borrowing’ information from more common species (Thorson et al., 2016, 2015). The ‘rules of thumb’ used to identify where estimators could be improved are given as a preliminary screening. These thresholds help to identify which species to focus improvements on, but we also suggest a devoted study focused on these rarer species to fine-tune the estimator quality indicators.

We must also acknowledge biases in catch recording which could not be addressed in this study. The reliability of self-sampled data is subject to increased criticism (Kraan et al., 2013), given that the data will directly influence management decisions. The standard approach to quantifying reliability is through comparison with a data source of ‘known’ reliability (Roman et al., 2011). Such a study is yet to be done for the Norwegian Reference Fleet, but we argue based on values that the Norwegian Reference Fleet provide an overall reliable report of total catches. The programme is a trust-based collaboration, which is reflected in personal conversations and official meetings where fishers express their willingness to participate in scientific research. Furthermore, fishers are paid under a contract to deliver high-quality data. Reliability is nevertheless dependent on the conservation status and management regulations, which differs between vessel groups, fishing gears, and species.

4.2. Generalisation

The Norwegian Reference Fleet has adapted sampling designs for different fishing gears to account for unique characteristics and sampling limitations (Clegg and Williams, 2020). The ratio estimator is nevertheless extendable to other gear-specific measures of fishing effort, given a strong correlation with total catches across vessels. The Norwegian Reference Fleet also has a coastal component, which again differs slightly to the sampling design for offshore vessels. Coastal fishing vessels in the Norwegian Reference Fleet do census reporting of total catches given the smaller scale of fishing activity. The cluster ratio estimator is nevertheless applicable, except for the need to estimate total catches per vessel (Equation 3.1) which is already known.

Coastal vessels in the Norwegian Reference Fleet explicitly record the discarded and retained portions of the total catch, allowing for a direct estimate of discarding. In 2019, the offshore Reference Fleet began a transition to recording retained catches, discards, and fishmeal explicitly, rather than a single value for total catch. Direct observations of discards remove the need to infer unreported catches through a comparison with reported catches. The cluster ratio estimator will still be applicable in the context of discards, given that there is a strong relationship with the chosen measure of fishing effort.

5. Conclusions

We recommend the use of cluster estimators for unreported catches using data from the Norwegian Reference Fleet. Our methodology has revealed both the scale and dynamics of estimation accuracy across species, which informs where estimates are reliable, and where improvement efforts should be focused. The difficulties in evaluating the representativeness of data, coupled with variable relationships between total catches and fishing effort (number of hooks), means that it is not possible to conclude a single best estimator for all species. There are clear indications that the cluster unit estimator is not unbiased as theoretically expected due to nonrepresentative sampling of vessels that are more active in the fishery. Whilst there are biases with the cluster ratio estimator, they are identifiable by evaluating the relationship

between total catches and fishing effort. We therefore recommend based on best practice methodology (ICES, 2007) that the unit and ratio estimator are applied and compared. If large differences are found, then further investigations can identify the reasons. We have defined two ‘rules of thumb’ to identify unreliable estimates: annual total catch estimates should be treated with caution for rare species with an encounter rate below 10 % or Pearson’s correlation coefficient below 0.25. These thresholds are useful for evaluating the quality of estimates and specifically where further improvements are needed. These values are however preliminary and could benefit from refinement to improve the evaluation of estimation quality.

CRedit authorship contribution statement

Thomas Clegg: Conceptualization, Methodology, Investigation, Formal analysis, Writing – Original draft Edvin Fuglebakk: Methodology, Investigation, Writing – review and editing. Kotaro Ono: Investigation, Writing – review and editing, Supervision.

Declaration of Competing Interest

The authors declare that they have no known competing financial interests or personal relationships that could have appeared to influence the work reported in this paper.

Data availability

The data underlying this article cannot be shared publicly due the sensitivity of the contents and the privacy of fishers involved in data collection. The data will be shared on reasonable request to the corresponding author.

Acknowledgements

We would like to thank the fishers participating in the Norwegian Reference Fleet, past and present, for contributing data and knowledge to this study. We also thank Kjell Nedreaas and Geir Blom for their comments on an earlier draft of the manuscript. This work was funded equally by the Norwegian Institute of Marine Research and the Norwegian Directorate of Fisheries.

Appendix A. Supporting information

Supplementary data associated with this article can be found in the online version at [doi:10.1016/j.fishres.2023.106686](https://doi.org/10.1016/j.fishres.2023.106686).

References

- Aanes, S., Pennington, M., 2003. On estimating the age composition of the commercial catch of Northeast Arctic cod from a sample of clusters. *ICES J. Mar. Sci.* 60, 297–303 [https://doi.org/10.1016/S1054-3139\(03\)00008-0](https://doi.org/10.1016/S1054-3139(03)00008-0).
- Aldrin, M., Mortensen, B., Størvik, G., Nedreaas, K., Aglen, A., Aanes, S., 2011. Improving management decisions by predicting fish bycatch in the Barents Sea shrimp fishery. *ICES J. Mar. Sci.* 69, 64–74. <https://doi.org/10.1093/icesjms/fsr172>.
- Bærum, K.M., Anker-Nilssen, T., Christensen-Dalsgaard, S., Fangel, K., Williams, T., Vølstad, J.H., 2019. Spatial and temporal variations in seabird bycatch: Incidental bycatch in the Norwegian coastal gillnet fishery. *PLoS ONE* 14, e0212786. <https://doi.org/10.1371/journal.pone.0212786>.
- Batsleer, J., Hamon, K.G., van Overzee, H.M.J., Rijnsdorp, A.D., Poos, J.J., 2015. High-grading and over-quota discarding in mixed fisheries. *Rev. Fish. Biol. Fish.* 25, 715–736. <https://doi.org/10.1007/s11160-015-9403-0>.
- Berg, H.S.F., Nedreaas, K., 2020. Estimering av utkast i Norskt kystfiske med garn 2012–2018. Institute of Marine Research, Fiskeri og havet 2021–1.
- Berg, H.S.F., Clegg, T.L., Blom, G., Kolding, J., Ono, K., Nedreaas, K., 2022. Discards of cod (*Gadus morhua*) in the Norwegian coastal fisheries: improving past and future estimates. *ICES J. Mar. Sci.* 79, 1548–1560. <https://doi.org/10.1093/icesjms/fsac081>.
- Borges, L., Zuur, A.F., Rogan, E., Officer, R., 2005. Choosing the best sampling unit and auxiliary variable for discards estimations. *Fish. Res.* 75, 29–39. <https://doi.org/10.1016/j.fishres.2005.05.002>.

- Borges, L., Cocos, L., Nielsen, K.N., 2016. Discard ban and balanced harvest: a contradiction. *ICES J. Mar. Sci.* 73, 1632–1639. <https://doi.org/10.1093/icesjms/fsw065>.
- Breivik, O.N., Storvik, G., Nedreaas, K., 2016. Latent Gaussian models to decide on spatial closures for bycatch management in the Barents Sea shrimp fishery. *Can. J. Fish. Aquat. Sci.* 73, 1271–1280. <https://doi.org/10.1139/cjfas-2015-0322>.
- Breivik, O.N., Storvik, G., Nedreaas, K., 2017. Latent Gaussian models to predict historical bycatch in commercial fishery. *Fish. Res.* 185, 62–72. <https://doi.org/10.1016/j.fishres.2016.09.033>.
- Catchpole, T.L., Ribeiro-Santos, A., Mangi, S.C., Hedley, C., Gray, T.S., 2017. The challenges of the landing obligation in EU fisheries. *Mar. Policy* 82, 76–86. <https://doi.org/10.1016/j.marpol.2017.05.001>.
- Clegg, T., Williams, T., 2020. Monitoring bycatches in Norwegian fisheries - Species registered by the Norwegian Reference Fleet. *Rapp. fra havforskningen 2020–2028*.
- Clegg, T.L., Fuglebakk, E., Ono, K., Vølstad, J.H., Nedreaas, K., 2022. A simulation approach to assessing bias in a fisheries self-sampling programme. *ICES J. Mar. Sci.* 79, 76–87. <https://doi.org/10.1093/icesjms/fsab242>.
- Diamond, B., Beukers-Stewart, B.D., 2011. Fisheries discards in the North Sea: waste of resources or a necessary evil. *Rev. Fish. Sci.* 19, 231–245. <https://doi.org/10.1080/10641262.2011.585432>.
- Dingsør, G.E., 2001. Estimation of discards in the commercial trawl fishery for cod. *Dep. Fish. Mar. Biol. Masters thesis, University of Bergen*.
- Efron, B., Tibshirani, R.J., 1994. *An Introduction to the Bootstrap*. CRC Press.
- Fangel, K., Aas, Ø., Vølstad, J.H., Bærum, K.M., Christensen-Dalsgaard, S., Nedreaas, K., Overvik, M., Wold, L.C., Anker-Nilssen, T., 2015. Assessing incidental bycatch of seabirds in Norwegian coastal commercial fisheries: empirical and methodological lessons. *Glob. Ecol. Conserv.* 4, 127–136. <https://doi.org/10.1016/j.gecco.2015.06.001>.
- Fernandes, A.C., Oroszlányová, M., Silva, C., Azevedo, M., Coelho, R., 2021. Investigating the representativeness of onboard sampling trips and estimation of discards based on clustering. *Fish. Res.* 234, 105778. <https://doi.org/10.1016/j.fishres.2020.105778>.
- Gezelius, S.S., 2006. Monitoring fishing mortality: compliance in Norwegian offshore fisheries. *Mar. Policy* 30, 462–469. <https://doi.org/10.1016/j.marpol.2005.06.004>.
- Gilman, E., Perez Roda, A., Huntington, T., Kennelly, S.J., Suuronen, P., Chaloupka, M., Medley, P.A.H., 2020. Benchmarking global fisheries discards. *Sci. Rep.* 10, 1–8. <https://doi.org/10.1038/s41598-020-71021-x>.
- Gullestad, P., Aglen, A., Bjordal, Å., Blom, G., Johansen, S., Krog, J., Misund, O.A., Røttingen, I., 2014. Changing attitudes 1970–2012: evolution of the Norwegian management framework to prevent overfishing and to secure long-term sustainability. *ICES J. Mar. Sci.* 71, 173–182. <https://doi.org/10.1093/icesjms/fst094>.
- Gullestad, P., Blom, G., Bakke, G., Bogstad, B., 2015. The “Discard Ban Package”: experiences in efforts to improve the exploitation patterns in Norwegian fisheries. *Mar. Policy* 54, 1–9. <https://doi.org/10.1016/j.marpol.2014.09.025>.
- Hønneland, G., 2000. Compliance in the Barents Sea Fisheries. How fishermen account for conformity with rules. *Mar. Policy* 24, 11–19. [https://doi.org/10.1016/S0308-597X\(98\)00058-X](https://doi.org/10.1016/S0308-597X(98)00058-X).
- ICES, 2003. Workshop on discard sampling methodology and raising procedures. ICES Planning Group on Commercial Catch, Discards and Biological Sampling, Chalottenlund, Denmark 2–4 September 2003.
- ICES, 2007. Report on the workshop on discard raising procedures. ICES WKDRP CM 2007/ACFM:06 Ref RMC PGCCDBS. San Sebastian, Spain.
- ICES, 2021. Arctic Fisheries Working Group 2021 report. ICES Scientific Reports. 3:58. 817 pp.
- Karp, W.A., Breen, M., Borges, L., Fitzpatrick, M., Kennelly, S.J., Kolding, J., Nolde Nielsen, K., Viðarsson, J.R., Cocos, L., Leadbitter, D., 2019. Strategies Used Throughout the World to Manage Fisheries Discards – Lessons for Implementation of the EU Landing Obligation. In: Uhlmann, S.S., Ulrich, C., Kennelly, S.J. (Eds.), *The European Landing Obligation: Reducing Discards in Complex, Multi-Species and Multi-Jurisdictional Fisheries*. Springer, Cham, pp. 3–26. <https://doi.org/10.1007/978-3-030-03308-8>.
- Kelleher, K., 2005. Discards in the world's fisheries. An update (No. FAO Fisheries Technical Paper. No. 470.). Rome, FAO.
- Kennelly, S.J., 2020. Bycatch beknonn: methodology for jurisdictional reporting of fisheries discards – using Australia as a case study. *Fish Fish* 21, 1046–1066. <https://doi.org/10.1111/faf.12494>.
- Kraan, M., Uhlmann, S., Steenbergen, J., van Helmond, A.T.M., van Hoof, L., 2013. The optimal process of self-sampling in fisheries: lessons learned in the Netherlands. *J. Fish. Biol.* 83, 963–973. <https://doi.org/10.1111/jfb.12192>.
- Lohr, S.L., 2010. *Sampling: Design and Analysis*, 2nd ed. Chapman and Hall/CRC.
- Martin, T.G., Wintle, B.A., Rhodes, J.R., Kuhnert, P.M., Field, S.A., Low-Choy, S.J., Tyre, A.J., Possingham, H.P., 2005. Zero tolerance ecology: improving ecological inference by modelling the source of zero observations. *Ecol. Lett.* 8, 1235–1246. <https://doi.org/10.1111/j.1461-0248.2005.00826.x>.
- McBride, M.M., Fotland, Å., 1996. Estimation of unreported catch in a commercial trawl fishery. *J. Northwest Atl. Fish. Soc.* 18, 31–41.
- Moan, A., 2016. Bycatch of harbour porpoise, harbour seal and grey seal in Norwegian gillnet fisheries. Masters thesis, University of Oslo.
- Moan, A., Skern-mauritzen, M., Vølstad, J.H., Bjørge, A., 2020. Assessing the impact of fisheries-related mortality of harbour porpoise (*Phocoena phocoena*) caused by incidental bycatch in the dynamic Norwegian gillnet fisheries. *ICES J. Mar. Sci.* 77, 3039–3049 (<https://doi.org/com>).
- Nedreaas, K., Iversen, S., Grethe, K., 2015. Preliminary estimates of total removals by the Norwegian marine fisheries, 1950–2010. Working Paper #2015-94, Fisheries Centre, University of British Columbia, Vancouver, Canada.
- Nelson, G.A., 2014. Cluster Sampling: A Pervasive, Yet Little Recognized Survey Design in Fisheries Research. *Trans. Am. Fish. Soc.* 143, 926–938. <https://doi.org/10.1080/00028487.2014.901252>.
- NMFS, 2011. U.S. National Bycatch Report, U.S. Dep. Commer., NOAA Tech. Memo. NMFS-F/SPO-117E, 508 p. U.S. Department of Commerce, NOAA Technical Memo NMFS-F/SPO-117E, 508 p.
- Norwegian Directorate of Fisheries, 2021. Norske Omregningsfaktorer - For omregning av landet produktvekt av marin fisk og andre marine arter til rund vekt - for fiske i det nordlige Atlanterhavet og i andre farvann.
- Pennington, M., 1996. Estimating the mean and variance from highly skewed marine data. *Biometrics* 39, 281–286. <https://doi.org/10.2307/2530830>.
- Pérez Roda, M.A., Gilman, E., Huntington, T., Kennelly, S.J., Suuronen, P., Chaloupka, M., Medley, P., 2019. A third assessment of global marine fisheries discards. In: *FAO Fisheries and Aquaculture Technical, Paper No. 633*. FAO., Rome, p. 78.
- Pitcher, T.J., Watson, R., Forrest, R., Þórarvaldysson, H., Guesnette, S., 2002. Estimating illegal and unreported catches from marine ecosystems: a basis for change. *Fish Fish* 3, 317–339. <https://doi.org/10.1046/j.1467-2979.2002.00093.x>.
- Roman, S., Jacobson, N., Cadrin, S.X., 2011. Assessing the reliability of fisher self-sampling programs. *North Am. J. Fish. Manag* 31, 165–175. <https://doi.org/10.1080/02755947.2011.562798>.
- Thorson, J.T., Scheuerell, M.D., Shelton, A.O., See, K.E., Skaug, H.J., Kristensen, K., Warton, D., 2015. Spatial factor analysis: a new tool for estimating joint species distributions and correlations in species range. *Methods Ecol. Evol.* 6, 627–637. <https://doi.org/10.1111/2041-210x.12359>.
- Thorson, J.T., Ianello, J.N., Larsen, E.A., Ries, L., Scheuerell, M.D., Szuwalski, C., Zipkin, E.F., 2016. Joint dynamic species distribution models: a tool for community ordination and spatio-temporal monitoring. *Glob. Ecol. Biogeogr.* 25, 1144–1158. <https://doi.org/10.1111/geb.12464>.
- Wigley, S.E., Ascí, S., Benjamin, S., Chamberlain, G., Cierpich, S., Didden, J., Drew, K., Legault, C., Linden, D., Murray, K., Potts, D., Sampson, K., Tholke, C., 2021. Standardized bycatch reporting methodology 3-year review report - 2020: Reviewing SBRM years 2018, 2019, and 2020 (No. NOAA Technical Memorandum NMFS-NE-266).