

## Fish behaviour and acoustic sampling

Kjell Olsen

Olsen, Kjell. 1990. Fish behaviour and acoustic sampling. – Rapp. P.-v. Réun. Cons. int. Explor. Mer, 189: 147–158.

Fish behaviour may lead in several ways to uncertainties in acoustic abundance estimation. Practical echo-surveying work faces a number of situations where aspects of fish behaviour may be of importance. Unfavourable vertical fish distributions, such as when fish stay too close to the bottom or too close to the surface, have long been recognized. Considerably less is known about the impact on acoustic sampling of other behavioural patterns, including schooling as opposed to non-schooling, avoidance behaviour, or vertical migration.

Current knowledge in this field is reviewed, as are influences of varying fish behaviour on target strength, effects of sound absorption on fish concentrations, and avoidance reactions in survey situations. Some new experimental results, indicating a significant effect on target strength when fish change depth, are also presented.

*Kjell Olsen: Norwegian College of Fishery Science, University of Tromsø, Dramsveien 201 B, N-9000 Tromsø, Norway.*

### Introduction

Practical experience with quantitative echo-sounding methods has shown that in addition to acoustic data acquisition, a procedure for further evaluation of the obtained data is required. Such an evaluation should scrutinize the echo data and compare the acoustic samples with the fish samples, thus determining a basis for converting the "echo abundance" into fish quantities. Implicit in this conversion, although sometimes overlooked, are assumptions about the behaviour of the fish. Adequate information on fish behaviour may therefore be of considerable importance, but as such information has been difficult to obtain so far, echo-energy conversions are frequently made with an unknown risk of error.

Fish in nature show a variety of natural patterns of behaviour, adapted to the life of each particular species and to certain biological conditions. In acoustic surveys, particular behavioural patterns have long been known to lead to various difficulties. For instance, if fish are distributed too close to the bottom or too close to the surface, they may appear in the "shadow zones" of the echo sounder and may not be registered at all. If fish aggregate in concentrations that are too dense or in schools that are too large, another relatively unknown form of biasing, "shadowing phenomenon", may take place through attenuation of the transmitted sound signals passing through the school.

Many fish are known to react by showing avoidance behaviour when disturbed. Such reactions may take place whether the stimulus has a natural origin, or is artificially generated by, for example, the presence of a

surveying vessel. Avoidance behaviour in surveying situations may therefore also create uncertainties in the evaluation of acoustic data.

The common opinion has long been that in order to maintain neutral buoyancy, fish attempt to keep the swimbladder volume approximately constant during vertical migrations. More recent investigations seem to show that the physostomous fish species (clupeids, salmonids, cyprinids, etc.) have a limited ability to secrete gas in their swimbladders. As the acoustic back-scattering cross-section of a fish bears a close relation to the swimbladder size and form, this could indicate a depth dependence in the acoustic target strength of such fish species.

A great number of other common fish species, the physoclists (e.g., gadoids, sparids, etc.), can apparently regulate their swimbladders with ease. Their target strengths may therefore not be influenced during depth excursions, at least not to the same extent. This physiological difference between fish species may introduce ambiguity in the evaluation of target-strength data.

In the following, knowledge of fish behaviour related to acoustic sampling work is reviewed, and the necessity of future investigations and developments in methods is discussed.

### Natural patterns of behaviour: fish detection

Diurnal changes in fish distribution, for instance by schools forming closer to the bottom during the day and dispersing into shallow scattering layers at night, fre-

quently present a complicating factor in obtaining a reliable acoustic abundance estimate.

On some occasions such conditions have been observed to occur only in particular seasons and may be accounted for by adjusting the time for surveying (Dalen and Smedstad, 1983; Jakobsson, 1983). In other cases the conditions are just "unfavourable" and it may be necessary to support the routine methods by applying particular techniques, such as using towed bodies with "upwards" or "side-looking" echo sounders, or even carrying out comparative day/night surveys (Nakken and Rørvik, 1979; Thorne, 1983).

One precondition of the echo-integration method is that equal-sized fish of the same species contribute on average equally to the energy of an echo signal, if a proper time-varied-gain compensation is applied (Forbes and Nakken, 1972). In practical echo-surveying work this assumption may, however, lead to several difficulties when the behaviour of fish is also involved.

Aglen (1983) has demonstrated that weak single-fish echoes may cause a "beam threshold effect", leading to a "misjudging" of the effective sampling volume of the acoustic beam. This problem exists even if the acoustic targets are approximately equal, but it becomes considerably more difficult to deal with if a significant variation in target strengths occurs (Weimer and Ehrenberg, 1975; Nakken and Olsen, 1977; Foote, 1980a; Fedotova and Shatoba, 1983; Foote *et al.*, 1986).

Weak single-fish echoes may originate from small fish, fish positioned at the edge of the acoustic beam, fish without swimbladders, fish with "undersized" swimbladders, or fish in a particular "behaviour mode". The beam position problem may, in modern echo sounders, be handled technically, by applying "dual-beam" or "split-beam" techniques, but the fish behaviour and questions related to the depth-adaptation condition in fish, still have to be considered.

Underwater observations made some time ago by Russian scientists, when diving in a "bathyscaph", showed that when schools of herring dispersed at night, the herring could be found positioned in all spatial orientations ("sleeping"?). Buerkle (1983) also reported a considerable diurnal difference in behaviour, with a significantly less polarized swimming orientation at night.

Conversely, Beltestad (1974) and Olsen (1979, 1980) found that herring did maintain their schooling behaviour, with a high degree of "polarized" swimming even during the dark hours. Similar behaviour has also been reported for schools of migrating adult herring and for anchovy. Spawning cod, when observed in an "undisturbed" situation, have been shown to swim with a mean tilt of  $4-5^\circ$ , head down, but with a considerable spread in tilt angles (s.d. =  $\pm 16^\circ$ ) (Olsen, 1971). This behaviour did not change significantly between day and night.

The magnitude of error in acoustic estimates when "misjudging" behaviour has been dealt with by several

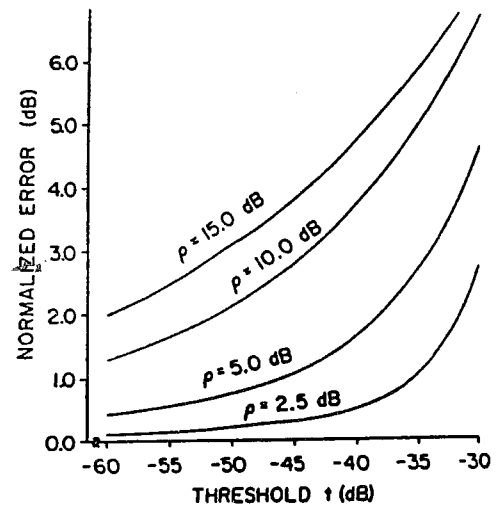

Figure 1. Normalized error versus threshold for the case of normally distributed target strength; mean values =  $-30$  dB and s.d. =  $\sigma$ . From Weimer and Ehrenberg (1975).

authors (Weimer and Ehrenberg, 1975; Foote, 1981; Olsen *et al.*, 1983b). Figure 1 shows a plot by Weimer and Ehrenberg of the normalized error of received echo energy versus signal threshold for assumed normally distributed target strengths (TS =  $-30$  dB) and varying standard deviation. When the standard deviation increases, the impact of the threshold is also seen to increase. The authors underline the risk of highly biased TS estimates due to this effect.

Figure 2 (from Foote, 1981) shows an example of

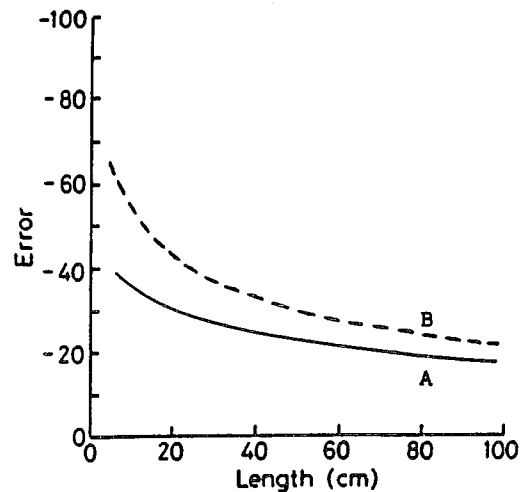

Figure 2. Percentage relative error in abundance estimation of cod stocks (38 kHz) when tilt angle distribution is  $(-4.4 \pm 16)$ , but is judged to be  $N(0 \pm 5)$  in choosing TS/length regression (A) and vice versa (B). From Foote (1981).

misjudging the behaviour of cod. The author calculated the abundance-estimate error when a TS/length regression equation is applied to cod showing "moderate aggregated behaviour" (mean tilt  $-4.4^\circ$ , s.d. =  $\pm 16^\circ$ ), when the actual behaviour was "schooling" (mean tilt  $0^\circ$ , s.d. =  $\pm 5^\circ$ ), and also the result in the opposite case. Such a variation in mean target strength is assumed to be a function of the "individual directivity" in acoustic backscattering and of the spatial orientation distribution.

At a particular frequency, the directivity of small fish at moderate tilt angles is less than that of bigger fish, and the effect of variation in tilt may be assumed to be most significant when fish are big (Fig. 3, from Foote and Nakken, 1978). Foote, in the above-cited example, however, shows that this tendency is not always consistent and may also reflect characteristics in the directivity pattern of acoustic backscattering (lobe-patterns) as well as the tilt-angle distribution.

When fish density increases and "multiple echoes" occur, the echo thresholding problems diminish (Aglen, 1983). Røttingen (1976) showed that the linearity in backscattered echo energy is only true for a limited number of fish within the echo-sounder beam. Foote (1978) concluded that this fish density "threshold" could also be behaviour dependent. Furusawa *et al.* (1982), in a cage experiment with yellowfin tuna ( $l = 75$  cm), demonstrated that the extinction of sound within the school was frequency dependent, with the greatest extinction at higher frequencies. The fish density in this experiment was high ( $44 \text{ kg/m}^3$ ), and the attenuation coefficients were measured at 1–4 dB/m.

When a fish school becomes large enough or dense enough, a sampling problem due to sound attenuation may be indicated by a significant change in the bottom echo strength. A similar effect may also be seen with horizontal sonars, when the distant parts of schools frequently appear to have a "reduced" fish density.

Models for correcting the "biomass loss" in such situations have been considered by Lytle and Maxwell (1983) and by Foote (1982). Both approaches require some *a priori* estimation of the sound extinction within the schools observed. Such information is difficult to obtain in field situations, and Olsen (1986) has suggested a modified method for an approximate compensation. The method is based on a separate echo-energy recording in the front part of a school (an assumed "non-attenuated" echo signal) and a comparison with schools for which the fish density and the sound attenuation coefficient have been determined.

When applying the model suggested by Foote:

$$\epsilon_{\text{tot}} = \frac{1 - \exp(-2v\sigma_e\Delta Z)}{2v\sigma_e\Delta Z} \sum_{i=1}^N \epsilon_i, \quad (1)$$

where ( $\epsilon_{\text{tot}}$ ) gives an approximate calculation of total echo abundance in a fish school if sound attenuation occurs, ( $v$ ) is fish density, ( $\sigma_e$ ) is extinction cross-section per fish, ( $\Delta Z$ ) is depth extension of ( $N$ ) fish uniformly distributed, and ( $\epsilon_i$ ) is mean echo intensity from the ( $i$ )th fish, were there no extinction, an estimation of biomass loss is obtained.

If the sound attenuation rate ( $\alpha_b$ ) is observed to be

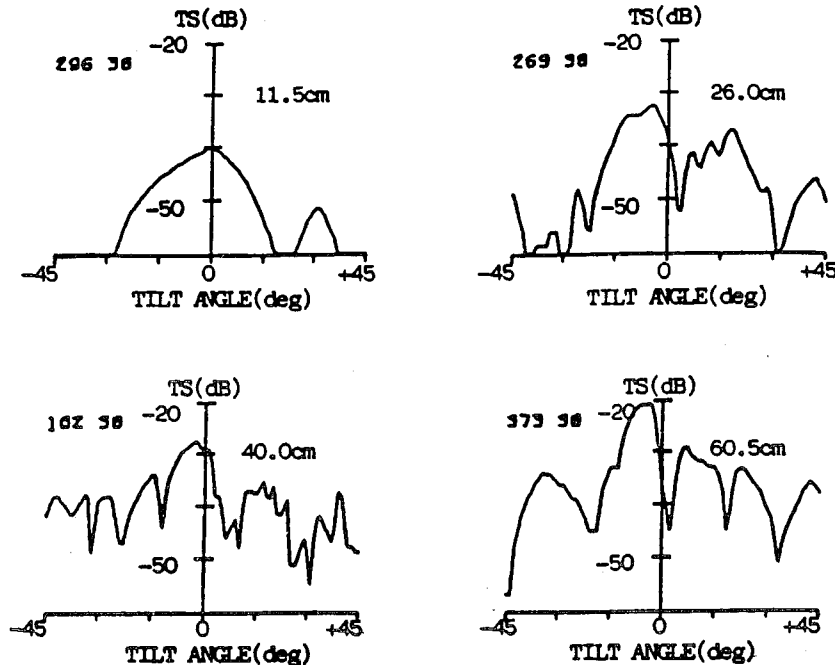

Figure 3. Dorsal-aspect target-strength functions (38 kHz) of cod of different lengths (11.5 cm, 26.0 cm, 40.0 cm, and 60.5 cm). (Negative tilt angle: "head down"). From Foote and Nakken (1978).

approximately constant, as in the schools observed by Olsen (1986), this also means that the product of the extinction cross-section per fish and the fish density is approximately constant (Clay and Medwin, 1977). This finding may confirm the observations made by Foote (1978) of a "behaviour-dependent" sound extinction, although the number of observations was too few for any evident conclusion. An estimation of correction factor versus school depth extension is shown in Figure 4 (from Olsen, 1986).

The extinction cross-sections, if sound absorption is ignored, were also found to be approximately linearly proportional to the backscattering cross-sections. When assuming the backscattering cross-section to be proportional to the square of the fish length (Foote *et al.*, 1986), then the observed fish densities were inversely proportional to the same dimension.

Pitcher and Partridge (1979), however, in a review of reported schooling densities in fish, arrived at the conclusion that schooling fish densities were in general inversely proportional to the cube of the fish length. More information on typical schooling densities of fish of different species, different sizes, and in different biological conditions, seems therefore to be needed.

## Avoidance behaviour – changes of fish density and spatial orientation

A behaviour pattern called "fountain manoeuvres", or more precisely, an evasion moving individuals out of the path of a predator, is quite typical in nature (Hall *et al.*, 1986). Towed fishing gear on the bottom create situations where such avoidance manoeuvring frequently takes place, and such a pattern of behaviour may also occur, when pelagic fish at shallow depths are approached by a vessel at full speed (Mohr, 1971; Olsen, 1971b; Diner, 1986; Aglen, 1985).

One severe difficulty when investigating whether or not avoidance takes place, lies in obtaining the desired conditions that make it possible to compare fish density and behaviour before and during the passage of the surveying vessel. Owing to the technical limitations of common acoustic equipment, precise measurements of relevant behaviour parameters are notoriously difficult to obtain on board a surveying vessel, and only a few observations are reported.

The application of modern multi-beam sonars with high resolution and the possibility of tracking the "true motion" of both fish schools and the surveying vessel has provided a method for collecting such information (Bodholt and Olsen, 1977; Diner, 1986; Aglen, 1985). In a recent study by Misund (1986) that used such equipment, the behaviour of herring schools was ob-

Figure 4. Estimated "correction factor" for echo abundance of schools of herring versus school depth extension; sound attenuation rate  $\alpha_b = 0.15 \text{ dB} \pm 25\%$ . From Olsen (1986).

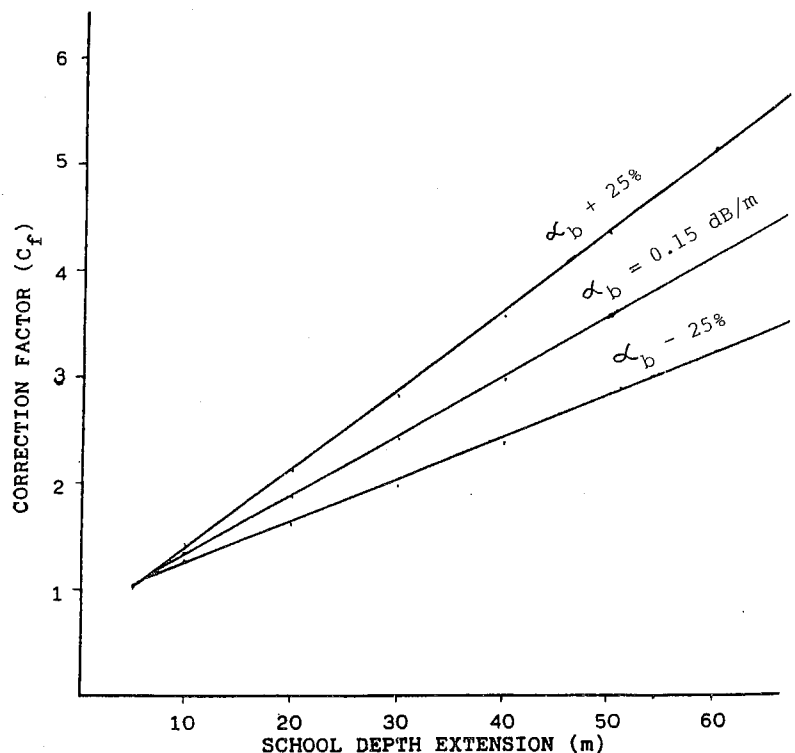

served during purse-seine operations as well as when fishing vessels approached and passed over schools. The observations confirm the findings reported by Olsen *et al.* (1983b) of a general trend for the schools to turn away when a vessel approached. A tendency to descend when a vessel passes was frequently observed, most significantly in schools of prespawning herring. This behavioural pattern was, however, not as consistent as earlier reported. The technique did not allow precise estimates to be made of density reductions in the schools when passed over, but these were indicated only sporadically.

In the experiments reported by Olsen *et al.* (1983a and b), when observing behavioural reactions of fish to a submerged stationary echo-sounder transducer, density reductions beneath a passing vessel were indicated on a number of occasions. When fish were also avoiding the gear by downward-orientated swimming, the echo recording was frequently observed at some moment partly to disappear. This creates some uncertainty as to whether a true density reduction beneath the vessel took place, or whether the dynamic range of the echo sounder was insufficient to record echoes of fish in extreme "diving" aspects.

In some recent experiments undertaken by the author, avoidance behaviour of herring at night has been further observed by obtaining simultaneous echo recordings from two submerged transducers, one positioned in the path of a running vessel and the other positioned about 15–20 m to the side. Records were obtained by "chopping" the transmissions/received signals of the two transducers, giving paper recordings as shown in Figure 5 (paper speed, 6 mm/s). Each second "single-echo" recording in Figure 5 is then obtained by the "path transducer" and the "in between" recordings are obtained by the "aside positioned transducer".

Differences in the recordings obtained in the two

positions clearly indicate a difference in behavioural reactions by the fish at the two locations. The echo signals were tape recorded and have later been "decoded" and displayed on a colour display as individual recordings of each transducer. The "path transducer" recordings in one of these runs are shown in Figure 6A and indicate a considerable echo-signal reduction owing to the descending behaviour of the herring and also probably to some density reduction. (Each colour change represents a 3 dB change in echo intensity.) The "aside transducer" recordings (Fig. 6B), show a much less significant reduction in signal strength for a short moment during and just after passage of the vessel and may indicate that only a small, if any, fish density reduction took place.

Figure 7 shows plots of the integrated echo signals obtained during the events shown in Figure 6. In both positions the integrated echo energy shows some increase during the approach of the vessel and then decreases dramatically at the moment when the vessel passes. When the reaction has apparently faded away, there appears to be a permanent reduction in the signal strength in the path area. The "aside transducer" signals, on the contrary, re-establish and for some moments even show a slight increase in strength, perhaps owing to an evasion of fish moving out of the path area. The trend towards an increase in echo signal strength during the vessel approach may be explained by an increased "polarization" of the fish due to the avoidance reaction, or perhaps more speculatively, by a "fish density wave" migrating ahead of the running vessel.

Figures 8A and B show pictures of recordings obtained in a similar experiment in another area. The reactions are not as significant as in the experiment described above, although the "hole" in the recordings obtained by the "path" transducer, again indicates some fish density reduction at the moment when the vessel

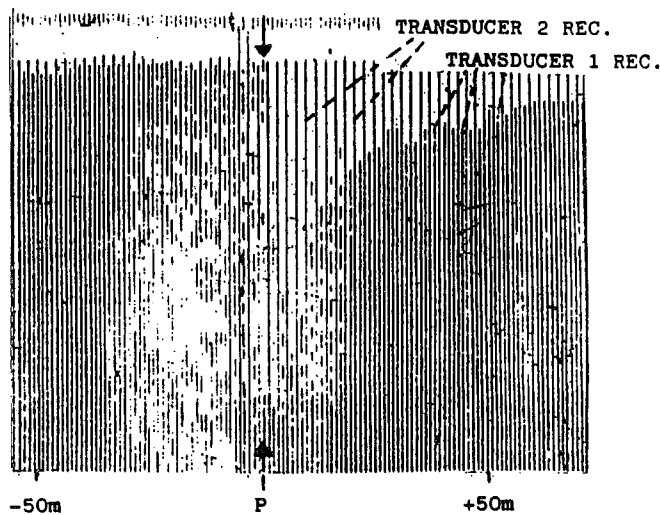

Figure 5. Echo recording of school of adult herring at night, obtained by two stationary transducers (70 kHz) submerged at 10-m depth, one positioned in the path beneath a running vessel (300 t, 9 knots) and the other positioned 15–20 m to the side. Every second single-echo recording corresponds to one transducer. P: vessel passage.

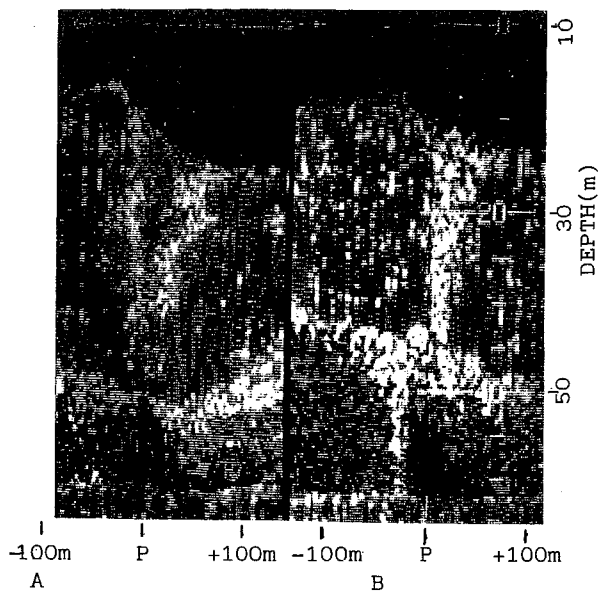

Figure 6. Photograph of echo recordings obtained by two stationary echo-sounder transducers (Simrad EY-M, 70 kHz), submerged at 10-m depth, during passage of RV "Johan Ruud" (300 t, 9 knots). Ramfjord (Run 1). A: Transducer submerged in the vessel path. B: Transducer submerged 15–20 m to the side of the vessel path. P: moment of vessel passage (position of the hull-mounted echo-sounder transducer).

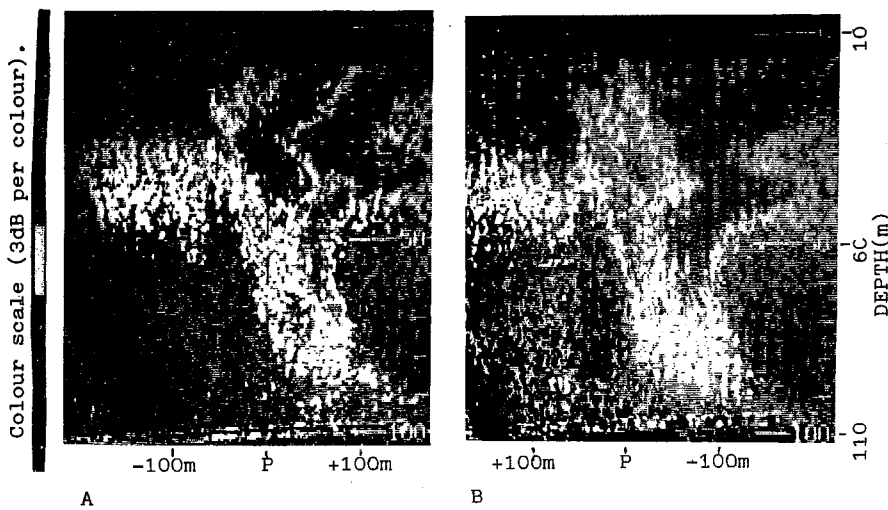

Figure 8. Photographs of echo recordings obtained by a method similar to that used in the experiment shown in Figures 6 and 7. Øyhellesundet (18 September 1987, Run 4). A: "path transducer" recording. B: "aside transducer" recording.

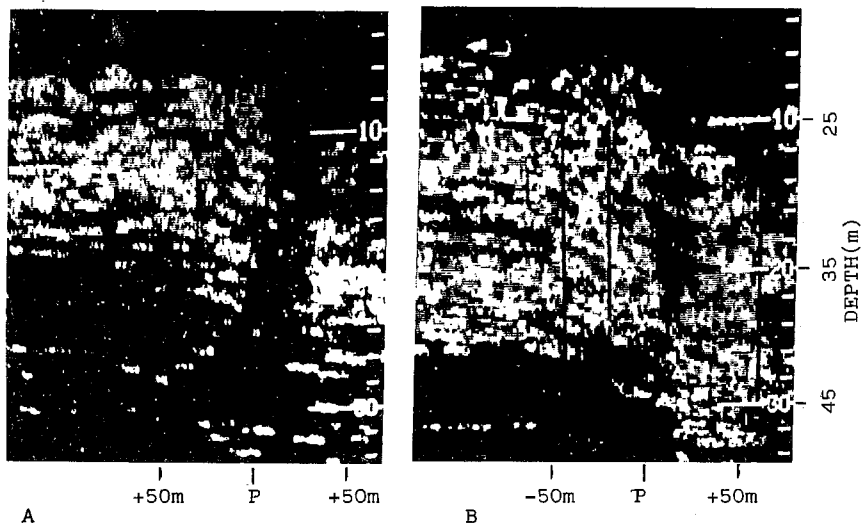

Figure 9. Photographs of echo recordings obtained with one stationary submerged transducer in the vessel path at 15-m depth. A: small herring ( $\bar{l} = 22$  cm), Balsfjord, March 1979, night. B: medium herring ( $\bar{l} = 25$  cm), Balsfjord, March 1980, night.

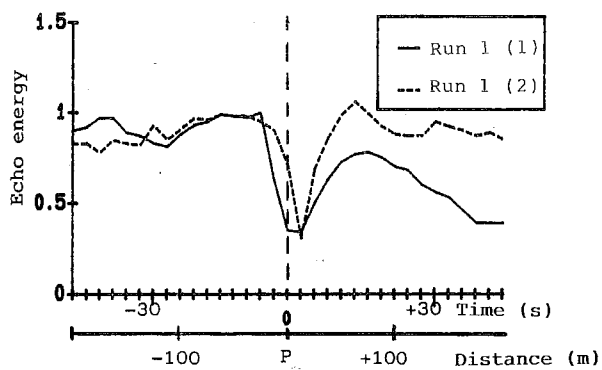

Figure 7. Plots of integrated echo intensity obtained during the sequence of events shown in Figure 6. P: moment of vessel passage.

passes. Of note is the apparent visibility of fish at greater depths when the reaction fades away after the propeller passes (descending stops?).

By applying the same displaying technique to some earlier echo recordings of herring schools during passage of a surveying vessel (Olsen, 1979, 1981), further details have been obtained (Fig. 9A and B). The figures illustrate situations where most of the fish dive and due to the changed dorsal aspect give reduced echoes. The "dynamics" of the events in the behavioural reaction are clearly indicated, and the reaction seems to continue developing for some moments after the passage of the front part of the vessel (position of the hull-mounted transducer). The fish density in these observations is apparently not significantly influenced, but the individual TS reaction is frequently in the order of  $-12$  to  $-15$  dB or more (4–5 colour steps). Such a situation may lead to the "threshold effect" discussed earlier, if target-strength distributions are produced.

The conclusion to be drawn from these observations may be that situations exist where avoidance behaviour in fish causes density reactions, but in general "diving" avoidance is the more important behaviour. The detection of such behaviour, on board a surveying vessel, is, however, possible only if the dynamic range of the applied echo sounder is sufficient.

When fish meet an approaching vessel, they typically turn away from the vessel, gradually increase their swimming speed, and at some moment, begin to descend (Olsen, 1979; Olsen *et al.*, 1983a). Some degree of "nervousness" always seems to occur, but the magnitude of the avoidance reaction depends upon the species involved, biological conditions, and the acoustic and visual effects of vessel passage.

The acoustic effect of such changes in fish behaviour may be related to a changed horizontal distribution, a changed mean tilt angle, a changed "spread" in tilt angles and on some occasions a changed fish density. Foote (1980a), in his model estimating TS/length regression equations of gadoid fish, assumed a random, hori-

zontal swimming orientation. This assumption may not be correct, in particular if fish are influenced by the surveying vessel. The acoustic effect of such a change in horizontal swimming orientation may not be significant in itself, but if this behavioural change is accompanied by increased "polarization" of the fish, the impact will be greater.

In a recent study Foote has recalculated his earlier TS/length regression equations for cod, saithe, and herring. Assuming a constant spread in tilt ( $\pm 5^\circ$ ), the mean target strengths are expected to change in accordance with the mean tilt angle as shown in Table 1. For comparison, data obtained on live capelin in a cage experiment by Olsen and Angell (1983) are also presented. The target strengths of cod, saithe, and herring all show greater dependence on changes in mean tilt than those of capelin. This could reflect a difference in fish size, or perhaps an "alive fish" effect.

Although changes in tilt-angle distributions in fish are recognized as an important factor in determining acoustic backscattering (Foote, 1980c), the literature shows considerable confusion as to situations where this factor has to be considered of importance. For instance, Figure 10 shows distributions of target strengths of cod, saithe, and herring obtained by a split-beam echo-sounder technique (Foote *et al.*, 1986). All distributions of the respective species are obtained from fish of relatively equal size.

The great spread in target strength, particularly for the gadoids, may indicate considerable variation in individual behaviour. Accordingly, a difference in mean

Table 1. Estimated change in target strength (TS) in cod, saithe, and herring with changes in mean tilt orientation (s.d. =  $\pm 5^\circ$ ) (from Foote, 1980, recalculated by the author, assuming:  $TS = 20 \log l + b$ ), and observed change in TS of live capelin ( $l = 18.2$  cm, s.d. =  $\pm 4.8^\circ$ ) (from Olsen and Angell, 1983).

Mean tilt angle ( $^\circ$ )	Target-strength changes (dB)			
	Cod	Saithe	Herring	Capelin
<b>"Head up"</b>				
+30	-11.2	-12.2	-11.4	
+25	-10.4	-10.7	-10.7	
+20	-8.0	-9.1	-9.7	
+15	-6.3	-6.9	-7.5	
+10	-4.2	-3.4	-4.5	
+5	-2.9	-2.1	-1.8	-1.4
0	-0.8	-0.3	-0.2	-0.5
<b>"Head down"</b>				
-5	0	0	0	0
-10	-0.7	-1.6	-1.0	0
-15	-2.7	-4.8	-3.3	-1.5
-20	-5.7	-8.8	-6.0	-1.8
-25	-8.7	-11.8	-8.4	-3.3
-30	-10.8	-13.3	-10.6	-4.0

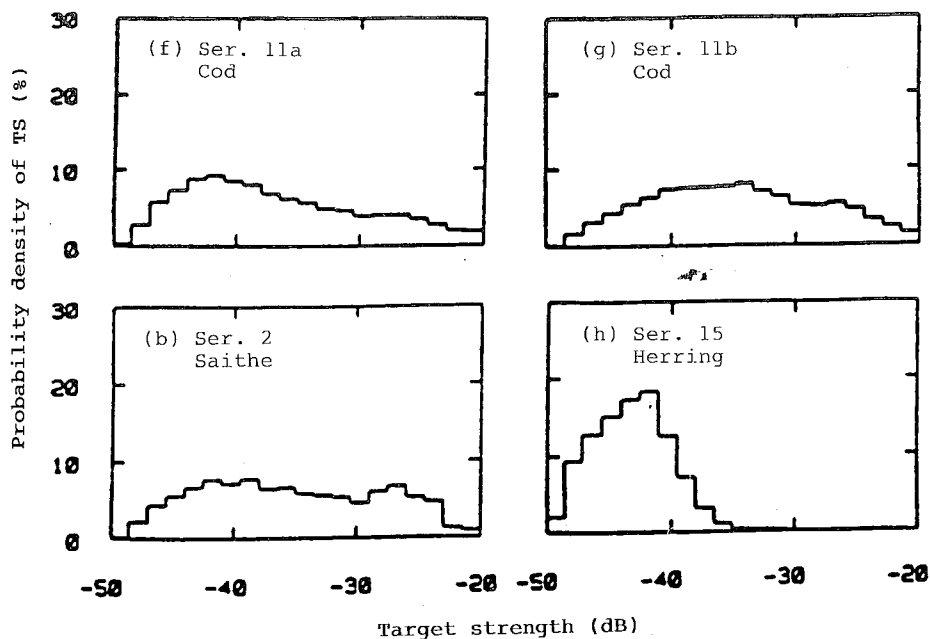

Figure 10. Target-strength histograms of cod, saithe, and herring derived by split-beam echo sounder. From Foote *et al.* (1986).

target strength between saithe and cod in the order of +3 dB, is difficult to explain, unless a difference in tilt-angle distribution is assumed. The distributions of target strengths of cod obtained at different vessel speeds (11.3 knots (f) and 3.3 knots (g)), seem to support earlier observations of a more pronounced avoidance reaction when a vessel passes at faster speed (Olsen *et al.*, 1983a). This may then result in an increased number of small/reduced target strengths (increased descending behaviour).

One method for detecting whether or not descending behaviour of dispersed fish takes place, applicable on board a surveying vessel, has been to study the trace form of expanded single-fish echo traces (Foote, 1981). Olsen (1979) reported trace analyses for herring at 20–60-m depth at night when the vessel ran at different speeds and concluded that about 80% of the herring traces indicated a downward swimming orientation. In a later report (Olsen, 1981), when herring were observed under other conditions, the downward trend was significantly less pronounced, even if the fish were generally avoiding the passing vessel by descending, when recorded on a submerged stationary echo-sounder transducer.

Halldórsson (1983), applying a similar method, observed a trend towards downward orientation in herring in an Icelandic fjord when the research vessel was running at relatively low speeds, but no dramatic descent was indicated. However, in trace analyses of capelin obtained at 140–180-m depth at night, Olsen and Angell (1983) showed a distinct downward migration when the research vessel (RV "G. O. Sars") steamed at 8 knots.

Several possible biasing factors exist in such analyses. Among them are the horizontal orientation and movement of a fish during a recording and the acoustic-target directionality of the fish in relation to observation beam angle. Most critical, however, would be the effect of a detection threshold that only allowed fish in an acoustically favourable spatial orientation to be registered. This could complicate both identification and counting of single-fish echo traces and could greatly bias target-strength distributions.

Several authors have reported that schooling fish, when scared, will typically respond by forming a "tighter" school of more highly polarized fish (Shaw, 1969; Hering, 1968; Olsen, 1969). If descent does not take place, this may increase the mean target strength of the fish significantly (Olsen and Angell, 1983). If a descent of some magnitude does take place, however, increased polarization may result in a more significant drop in the backscattering strength due to increased scattering directionality.

The foregoing emphasizes that when avoidance reactions occur, the precise moment when the echo recording is obtained may be of vital importance for the received echo energy (Figs. 7–9). The magnitude of and dynamics in such a behavioural pattern have been shown to be related to factors such as the speed of the surveying vessel and the depth distribution of the fish (Olsen *et al.*, 1983). The latter suggest, on the basis of empirical data, that functional depth dependence in a reaction pattern is related to noise stimuli generated by the vessel. Such a generalization presents difficulties. For instance, at night, light stimuli from a vessel have been shown to be of importance. Different surveying



conditions in different seasons also have to be considered.

### Vertical migration: changes in acoustic backscattering

When fish with swimbladders are descending, the increased hydrostatic pressure may change both the volume and form of the swimbladder, unless the fish compensate for this by gas secretion. A swimbladder volume less than "normal" will, in addition to a most probable reduction in acoustic-scattering strength, also give the fish a negative buoyancy. In order to avoid sinking, the fish will have to adjust for this by swimming.

Numerous observations by fishermen of fish that are "overbuoyant" when brought to the surface, indicate that species such as cod, saithe, redfish, etc. (physoclists), live in a condition of approximate neutral buoyancy at all depths. When such fish undertake vertical migrations, a fair hypothesis may therefore be that they do not migrate faster than their gas production or gas resorption systems allow.

From experiments it is known that both cod and saithe possess the ability to absorb a quantity of gas greater than their swimbladder volume within some tens of minutes (Lien, 1981; Larsen, 1986). The gas secretion process may be slower, but it is probably well adapted to the life pattern of each species. Consequently, physoclist fish species may be regarded, in general, as having target strengths relatively independent of depth or any prehistory of vertical migration.

Physostomous fish, on the contrary, apparently lack a specialized "gas-gland" for secretion of gas into the swimbladder. It is therefore doubtful if these fish have any ability at all to refill their swimbladders, apart from swallowing air at the surface. Sundnes and Sand (1975) showed, however, that at least one physostome species, the Arctic char (*Salvelinus alpinus*), possesses such an ability, but the process is very slow.

Recent studies by Blaxter and Batty (1984) and Ona (1984), leave few doubts that herring are unable to secrete gas in their swimbladders. On the other hand, one apparently good reason for believing that they nevertheless do so, is the well-known phenomenon of their releasing gas when they ascend. The gas is frequently observed as bubbles on the surface (Sundnes and Bratland, 1972).

Fish species such as herring frequently undertake vertical migrations from 2 to 300-m depth to surface. As the swimbladder may account for 90–95% of the reflected acoustic energy (Foote, 1980b), a compression to 1/20 or less of its normal size would presumably have a great impact on the acoustic backscattering. Although herring are very frequently observed by echo sounders, only one report, by Halldórsson (1983), presents data

obtained *in situ* which indicate the existence of this phenomenon.

Halldórsson (1983) investigated the variation of herring target strengths with depth and also attempted by echo-trace analyses to learn whether any avoidance behaviour took place. If fish avoid a surveying vessel by downward-orientated swimming, this reaction is assumed to diminish with increasing depth. If their swimming then becomes more horizontal, the relative backscattering strength increases (Fig. 8A and B). Target strengths of fish at varying depths may therefore be affected by a combination of these two opposite effects.

Halldórsson demonstrated a weak trend towards descent in the herring, but concluded that there were no significant differences in the behaviour with depth. The target strength, however, showed a strong depth dependence, which he related to the pressure as:

$$TS = 17.9 \log I - 65.5 - 10.3 \log P,$$

P = excess pressure (atm.).

This, for instance, gives a mean TS of a 30-cm herring at 10-m depth of -42.2 dB, and at 100-m depth of -49.8 dB (83% reduction).

Olsen and Angell (1983) reported estimates of echo-integrator "conversion factors" ("C"-values) from capelin at various depths (20–160 m) and found no systematic variation with depth. The capelin in this situation showed moderate avoidance reactions with downward-orientated swimming which, however, tended to be reduced at greater depths.

Traynor and Williamson (1983), when measuring target strengths of walleye pollock (physoclists), observed a significant increase in TS at greater depth during daytime, which they suggested may originate from a stronger avoidance reaction in fish when staying at shallower depths at night (50–100 m).

In investigations of whether or not differences between day and night occurred in the echo abundance of herring, Olsen (1981) reported that the majority of the herring migrated between 10 to 40-m depth at night and towards bottom at 70 to 80-m depth during the day. The discrepancy in echo abundance, about 2.5 times higher at night, may well be explained by a difference in TS as suggested by Halldórsson (3–4 dB).

In order to elucidate the problem of how target strength in fish may change during depth migrations, some introductory experiments have been carried out, applying a specially designed submersible "echo measurement rig" (Fig. 11). The rig permits measurements of the acoustic backscattering strength of fish inside a net cage at a controlled position in the echo-sounder beam during depth excursions. The behaviour of the fish is observed continuously by underwater TV.

When being towed forward at slow speed ( $\leq 0.5$  knots) at a given depth, the rig is designed to keep a stable and approximately horizontal position. This is controlled by streamers attached to the net cage in front

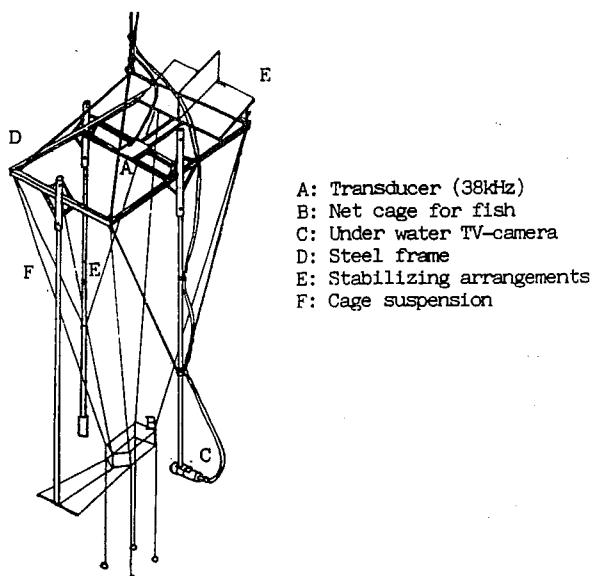

Figure 11. Submersible rig for measuring target strength of fish during depth excursions. Distance between transducer and net cage: 4.5 m. (All solid constructions are hidden in the "minimum zones" in the acoustic beam.)

of the TV camera. During such a tow, a fish inside the cage is assumed to take up a swimming position (tilt angle), which is dependent on its buoyancy and swimming speed.

In an experiment with a group of seven medium-sized herring ( $l = 26$  cm), TS-measurements were obtained at three different depths, 6.5 m, 35 m, and 65 m, respectively. At a speed of 0.3 knots ( $\pm 10\%$ ), the fish took a tilt orientation of  $0-5^\circ$  head up at 6.5-m,  $10-15^\circ$  head up at 35-m, and  $15-20^\circ$  head up at 65-m depth. The spread in tilt appeared to be quite constant. At slower speeds ( $< 0.2$  knots), the tilt, particularly at the greatest depth, increased significantly. The mean TS changed from  $-38$  dB at 6.5-m to  $-40.5$  dB at 35-m, and to  $-47.5$  dB at 65-m depth. An adaptation time of 30 min at 65 m before ascending did not appear to have any effect on either the behaviour or the TS of the fish.

A change in the mean tilt of herring of  $+2.5^\circ$  (head up) compared with the horizontal (s.d. =  $\pm 5^\circ$ ) ought to reduce the mean target strength by about  $-1$  dB; a change of  $+12.5^\circ$  may result in a reduction of about  $-5$  dB; and change of  $-17.5^\circ$  may reduce the mean target strength in the order of  $-8.5$  dB (Table 1). Subtracting these "behaviour effects" from the observed TS seems to indicate that although the swimbladder compression was at least 65% at 35-m depth, it apparently did not add any significant TS reduction to the effect caused by the change in tilt. At 65-m depth where the swimbladder compression was at least 80%, the swimbladder change may have reduced the mean target strength in the order of  $-2$  dB.

The results obtained show a somewhat stronger depth dependence in TS compared with the observations made by Halldórsson, but the lack of precise behaviour observations in the *in situ* material makes a direct comparison difficult.

In a similar depth excursion experiment with one cod in the cage (1–40 cm), the cod also showed some "under buoyancy" behaviour after the descent, but the TS was not significantly changed ( $-1-1.5$  dB). After an adaptation period of two hours at 65-m depth, the fish was lifted to 6.5-m depth for 15 minutes. For a short period of about 2–3 minutes the fish was clearly "over buoyant". When this disappeared the target strength was again found to have stabilized at the former level ( $-35$  dB).

Swimming speeds of 0.3–0.5 knots are comparable with *in situ* UWTV observations of herring in hibernating/feeding situations. The observed acoustic effect due to increasing "under buoyancy" may therefore also be expected to occur under natural conditions. However, if the behaviour is disturbed and the swimming speed increases significantly, the pattern of the behaviour reaction and the possible acoustic effect from compressed/deformed swimbladders will nevertheless be the main determining factors of the acoustic backscattering.

The results of these few experiments seem to support the hypothesis that there is a difference between physostomous and physoclistous fish species with regard to the impact of vertical migration on the acoustic target strength. Whether this difference bears a relation to a necessary time period for depth adaptation of the physostomous fish species, is still not known.

## Conclusions and future work

The available evidence on how fish behaviour may influence acoustic sampling leaves no doubt as to the need for improvement of the methods. Future developments in acoustic methods will most probably depend on both a better understanding of general patterns of behaviour in the different surveying situations, and direct observations of certain behaviour parameters.

Our knowledge today ought to call for efforts to improve the processing routines for collected data. For instance, acoustic sampling of high fish-density aggregations should no longer be carried out without a quantitative correction of echo-abundance losses due to sound attenuation. Averaging of the echo abundance along course tracks complicates such analyses, and a first step in the routine processing of such data may be the separate registration of "high echo-abundance transects" (school registration). A second step should then be the correction of echo abundance based on a model which includes both information obtained *a priori* on sound attenuation in schools and biological/acoustical information collected *in situ*.

Taking into account the observations of behaviour

reactions and the findings of the effect of excess pressure on acoustic backscattering, it seems evident that the common equation for expressing the acoustic target strength of fish:  $TS = a \log l + b$ , where  $l$  is fish length and  $a$  and  $b$  are "species/situation-averaged" constants, is by no means an oversimplification.

The "constant  $a$ " may express some fundamental acoustic/physical relationship to the target size and may not be affected by the above-mentioned factors. The "constant  $b$ ", however, which represents species characteristics and an assumption of an existing and predictable "average" behaviour characteristic in particular fish species, will in future need further precision.

The proposals made by Olsen *et al.* (1983a) to relate "b" also to the magnitude of the behaviour-generating stimuli of the surveying vessel, or by Halldórsson (1983), to add to "b" a direct excess-pressure dependent parameter (including behaviour effects), may still be somewhat premature, but they clearly point to important factors which may be considered for inclusion in an improved model.

It ought to be strongly emphasized that the acoustic target strength of a fish, which may depend on fish species, fish size, physiological conditions, and observation aspects, when observed under laboratory conditions, may differ significantly from the mean target strength of a group of the same fish observed under true surveying conditions. An essential question is therefore how and when this difference becomes of importance in acoustic sampling work.

The recent developments in echo-sounder techniques, both the dual-beam technique and in particular the split-beam technique, offer new possibilities for collecting useful information on fish behaviour when fish are dispersed. Such distributions are, however, not usual in perhaps a majority of surveying situations. This problem then focuses attention on questions such as: are fish "acoustically" similar when dispersed, compared with when they school, and are variations in behaviour of importance in fish which nearly always school?

The considerable evidence confirming that each species has a "natural response pattern", both when dispersed and when schooling, may in many situations be a partial answer to the first question. The eventual responses to a disturbing stimulus are, therefore, more closely related to the biological/surveying situation itself. The observed differences in behaviour between species seem, however, to make arriving at a general conclusion on the second question rather more difficult.

## References

- Aglen, A. 1983. Echo integrator threshold and fish density distribution. *FAO Fish. Rep.*, 300: 35–44.
- Aglen, A. 1985. Sonar observations of the behaviour of herring schools in relation to a fishing vessel. ICES Working Group on Fisheries Acoustics Science and Technology, Tromsø, May 1985.
- Beltestad, A. K. 1974. Feeding, vertical migration and schooling of 0-group herring (*Clupea harengus* L.) in relation to light intensity. Thesis, University of Bergen. 80 pp. (In Norwegian).
- Blaxter, J. H. S., and Batty, R. S. 1984. The herring swimbladder; loss and gain of gas. *J. Mar. Biol. Ass. U.K.*, 64(2): 441–450.
- Bodholt, H., and Olsen, K. 1977. Computer-generated display of an underwater situation: Applications in fish behaviour studies. *Rapp. P.-v. Réun. Cons. Explor. Mer*, 170: 31–35.
- Buerkle, U. 1983. First look at herring distributions with a bottom referencing underwater towed instrumentation vehicle "Brutiv". *FAO Fish. Rep.*, 300: 125–130.
- Clay, C. S., and Medwin, H. 1977. *Acoustical oceanography: Principles and applications*. John Wiley, New York, 544 pp.
- Dalen, J., and Smedstad, O. 1983. Abundance estimation of demersal fish in the Barents Sea by an extended acoustic method. *FAO Fish. Rep.*, 300: 232–239.
- Diner, N. 1986. Observations du comportement des bancs grâce à un sonar omnidirectionnel. ICES Working Group on Fisheries Acoustic Science and Technology, Hull, England, May 1986.
- Fedotova, T. A., and Shatoba, O. E. 1983. Acoustic backscattering cross section of cod averaged by sizes and inclination of fish. *FAO Fish. Rep.*, 300: 63–68.
- Foote, K. G. 1978. Analysis of empirical observations on the scattering of sound by encaged aggregations of fish. *Fisk. Dir. Skr., Ser. Havunders*, 16: 423–456.
- Foote, K. G. 1980a. Averaging of fish target strength functions. *J. acoust. Soc. Am.*, 67: 504–515.
- Foote, K. G. 1980b. Importance of the swimbladder in acoustic scattering by fish: A comparison of gadoid and mackerel target strengths. *J. acoust. Soc. Am.*, 67: 2084–2089.
- Foote, K. G. 1980c. Effect of fish behaviour on echo energy: the need for measurements of orientation distributions of fish. *J. Cons. int. Explor. Mer*, 39(2): 193–201.
- Foote, K. G. 1981. Acoustic investigation of fish behaviour apropos avoidance reaction. *ICES CM 1981/B:21*, 13 pp.
- Foote, K. G. 1982. Linearities of fisheries acoustics, with addition theorems. ICES/FAO Symposium on Fisheries Acoustics, Bergen, Norway, 21–24 June 1982. Doc. no. 43.
- Foote, K. G., Aglen, A., and Nakken, O. 1986. Measurement of fish target strength with a split-beam echo sounder. *J. acoust. Soc. Am.*, 80(2): 612–621.
- Foote, K. G., and Nakken, O. 1978. Dorsal aspect target strength functions of six fishes at two ultrasonic frequencies. *Fisken Hav. Ser. B.*, 1978(3): 96 pp.
- Forbes, S. T., and Nakken, O. 1972. Manual of methods for fisheries resource survey and appraisal. Part 2. The use of acoustic instruments for fish detection and abundance estimates. *FAO Man. Fish. Sci.*, 5: 138 pp.
- Furisawa, M., Ishii, K., and Miyanozana, Y. 1982. Simultaneous calibration method for precise measurements of target strength of fish and attenuation of sound by schooled fish. ICES/FAO Symposium on Fisheries Acoustics, Bergen, Norway, 21–24 June 1982. Doc. no. 25.
- Hall, S. J., Wardle, C. S., and MacLennan, O. N. 1986. Predator evasion in a fish school: test of a model for the fountain effect. *Mar. Biol.*, 91: 143–148.
- Halldórsson, O. 1983. On the behaviour of the Icelandic summer spawning herring (*Clupea harengus* L.) during echo surveying and depth dependence of acoustic target strength *in situ*. *ICES CM 1983/H:36*, 35 pp.
- Hering, G. 1968. Avoidance of acoustic stimuli by herring. *ICES CM 1968/H:18*.
- Jakobsson, J. 1983. Echo surveying of the Icelandic summer spawning herring 1973–82. *FAO Fish. Rep.*, 300: 240–248.
- Larsen, R. 1986. Fish selection and mortality in seine fishery. Project report (NFFR), University of Tromsø. (In Norwegian).

- Lien, K. 1981. Damage and mortality of live stored saithe (*Pollachius virens* L.) caused by handling. Thesis, University of Tromsø, Norway.
- Lytle, D. W., and Maxwell, D. R. 1982. Hydroacoustic assessment in high density fish schools. *FAO Fish. Rep.*, 300: 157-171.
- Misund, O. R. 1986. Observations of behaviour obtained by sonar during purse seining for herring. Thesis, University of Bergen, Norway. 115 pp. (In Norwegian).
- Mohr, H. 1971. Behaviour patterns of different herring stocks in relation to ship and midwater trawl. In *Modern fishing gear of the world*, 3, pp. 368-371. Ed. by H. Kristjansson. Fishing News Books Ltd, Farnham, Surrey, England.
- Nakken, O., and Olsen, K. 1977. Target strength measurements of fish. *Rapp. P.-v. Réunion. Cons. int. Explor. Mer*, 170: 52-69.
- Nakken, O., and Rorvik, C. J. 1979. Distribution and abundance estimation of 0-group Norway pout and haddock in the North Sea in July-August 1978. *ICES CM 1979/G:50*, 10 pp.
- Olsen, K. 1969. Directional responses in herring to sound and noise stimuli. *ICES CM 1969/B:20*, 8 pp.
- Olsen, K. 1971. Orientation measurements of cod in Lofoten obtained from underwater photography and their relation to target strength. *ICES CM 1971/B:17*, 8 pp.
- Olsen, K. 1979. Observed avoidance behavior in herring in relation to passage of an echo survey vessel. *ICES CM 1979/B:18*, 9 pp. + figures.
- Olsen, K. 1980. Echo surveying and fish behaviour. *ICES Fish Reaction Working Group Meeting*, Reykjavik, Iceland, May 1980. 20 pp. + 9 figures.
- Olsen, K. 1981. The significance of fish behaviour in the evaluation of hydroacoustic survey data. *ICES CM 1981/B:22*, 25 pp.
- Olsen, K. 1986. Sound attenuation within schools of herring. *ICES CM 1986/B:44*, 15 pp.
- Olsen, K., and Angell, J. 1983. A comparison of different echo abundance conversion methods. *ICES CM 1983/B:17*.
- Olsen, K., Angell, J., and Løvik, A. 1983a. Quantitative estimations of the influence of fish behaviour on acoustically determined fish abundance. Selected papers of the ICES/FAO Symposium on Fisheries Acoustics, Bergen, Norway, 21-24 June 1982. *FAO Fish. Rep.*, 300: 139-149.
- Olsen, K., Angell, J., Pettersen, F., and Løvik, A. 1983b. Observed fish reactions to a surveying vessel with special reference to herring, cod, capelin and polar cod. *FAO Fish. Rep.*, 300: 131-138.
- Ona, E. 1984. *In situ* observation of swimbladder compression in herring. *ICES CM 1984/B:18*, 15 pp.
- Pitcher, T. J., and Partridge, B. L. 1979. Fish school density and volume. *Mar. Biol.*, 54(4): 383-394.
- Røttingen, I. 1976. On the relation between echo intensity and fish density. *FiskDir. Skr. Ser. HavUnders.*, 16(9): 301-314.
- Shaw, E. 1969. Some new thoughts on the schooling of fishes. *FAO Fish. Rep.*, 62(2): 217-232.
- Sundnes, G., and Bratland, P. 1972. Notes on the gas content and neutral buoyancy in physostome fish. *FiskDir. Skr. Ser. HavUnders.*, 16: 89-97.
- Sundnes, G., and Sand, O. 1975. Studies of a physostome swimbladder by resonance frequency analysis. *J. Cons. int. Explor. Mer*, 36(2): 176-182.
- Traynor, J. J., and Williamson, N. J. 1983. Target strength measurements of walleye pollock (*Theragra chalcogramma*) and a simulation study of the dual beam method. *FAO Fish. Rep.*, 300: 112-125.
- Thorne, R. E. 1983. Application of hydroacoustic techniques to three lakes with contrasting fish distributions. *FAO Fish. Rep.*, 300: 269-277.
- Weimer, R. T., and Ehrenberg, J. E. 1975. Analysis of threshold-induced bias inherent in acoustic scattering cross-section estimates of individual fish. *J. Fish. Res. Bd Can.*, 32: 2547-2551.