

**REPORT OF THE SUB-GROUP ON THE SELECTION OF A DEMERSAL SAMPLING  
TRAWL FOR THE BALTIC SEA**

# ICES - Baltic Survey Trawl

## Intermediate subgroup report by the chairman

---

### Introduction

During the summer of 1996 a subgroup was established under the ICES Working Group on Fishing Technology and Fish Behaviour. The subgroup have the following composition:

- DIFTA, Denmark, Ulrik Jes Hansen, chairman of the subgroup
- DIFRES, Denmark, Klaus Lehmann
- Havs fiskelaboratoriet, Sweden, P.O. Larsson
- Bundesforschungsanstalt für Fischerei, Germany, Erdmann Dahm
- Sea Fisheries Institute, Poland, Jan Netzel
- Kaliningrad Fishery Institute, Russia, Valery Feldmann
- Fishery Research Laboratory, Lithuania, Šarūnas Tuliušis
- Latvian Fisheries Research Institute, Latvia, Maris Pliksh
- Estonian Marine Institute, Estonia, Arthur Hjörvik
- Finnish Game and Fisheries Research Institute, Finland, Eero Aro.

The group have made the preliminary contact by correspondence.

### Terms of reference

The terms of reference is given in ICES Council Resolution 1995, 2:16:

- .. advice the Baltic International Survey Assessment Working Group and the Baltic Fish Committee on a standard multispecies survey bottom trawl to be used for resource assessment in the Baltic Sea.

The resolution is justified by the following comment:

- Request from the Baltic Fish Committee. At present various standard trawl fitted to national research vessels are in use for resource assessment in the Baltic Sea. Two problems can be identified in relation to the use of a single standard gear. Firstly, national research vessels differ in size, engine, rigging, etc. Secondly, the variations in bottom topography and depth of the Baltic Sea restrict the use of presently employed trawls to specific parts of the Baltic. In their 1995 report the Study Group on Assessment-Related Activities Relevant to the Baltic Fish Resources concluded that measures to introduce new standard trawls should include expert advice on gear design and asked an appropriate Group under the Fish Capture Committee to advice on which standard trawl to use in the Baltic International Trawl Survey.

The Chairman of the Fish Technology and Fish Behaviour Working Group have furthermore requested that the subgroup: -

- .. consider the minimalist solution to selecting a survey trawl. i.e. to set a performance specification (towing speed, net and door spread, headline height, door and groundgear type, and floatation)

The problems the subgroup are asked to address are more specifically described in: ICES CM 1985/J:5, ICES CM 1995/J:1, and ICES CM 1996/J:1.

### **Tasks carried out**

Information about the present situation at the various institutes around the Baltic Sea have been collected, but is not yet complete. The type of information, which the institutes have been asked to deliver, comprise:

- Research vessels: length, engine power, layout of deck, special constraints or requirements,
- Trawls in use for stock assessment in the Baltic: design (complete net specification)
- Rigging: doors, sweeps, bridles, footrope, floatation,
- Mode of operation, towing speed, wire length,
- Topographic information about the investigated areas,
- All other information important for the selection of a new survey trawl, constraints and requirements.

### **Preliminary results**

#### *Vessels and gear*

The complexity of the problem is well illustrated by the material collected so far. In appendix 1 a scheme collects the information about the vessels and trawls used. In appendix 2 the design and relative size of 8 different trawls are given (the trawls are here drawn to the same scale).

The range of vessel sizes goes from 180 HP to more than 2000 making it very difficult to specify a trawl which is suitable for all research vessels due to the different towing power of the vessels. Moreover it seems that more than 8 different trawls have been used in the past for bottom trawl surveys in the Baltic. From the information collected it also appears that some of the institutes have used different types of bottom trawl in search of a trawl able to perform the wanted tasks.

A number of commercial trawl manufacturers have been contacted. They have been asked to give information about the nets which are used by the commercial fleet in the Baltic. Also they have given valuable information about the advantages and disadvantages of types of different ground gear for the bottom trawls. So far there are indications, but no direct evidence that there are fishermen who possess experience from using a rock-hopper ground gear.

#### *Stock assessment requirements*

In order to collect as much information as possible from one trawl the survey trawl must be able to provide:

- estimates of indices of the abundance and distributions of recruiting year-classes of cod
- estimates of indices of SSB (standing stock biomass) for cod,
- estimates of indices of SSB, distribution and recruitment of herring and sprat
- estimates of indices of SSB, distribution and recruitment of flatfishes.

Considering the present assessment problems for the Baltic cod stocks the BIFS Working Group (Baltic International Fisheries Surveys) recommends that priorities are given to the sampling of cod.

Furthermore it is preferred that the net can be used on all participating research vessels and can be used all over the Baltic Sea, despite different bottom conditions.

#### *Problems arising from stock assessment requirements*

To catch all sizes of cod a low opening trawl with a light footrope is preferred, but with this net, it will not be possible to exploit all areas of the Baltic Sea. In fact, maybe as little as 25% of the area where cod is distributed can be trawled with light gears. The fishermen and research vessels exploiting areas with very soft ground or very hard ground are mainly using 200 mm Ø or 300 mm

○ plastic bobbins. This type of groundgear are known to let a large fraction of the small fish escape in the opening between the fishing line and the seabed.

In the spring time the cod can be found in mid-water in the deeper parts of the Baltic Sea. The fishermen are then using high opening semi-pelagic trawls with large meshes in the front part. Although some of these nets have plastic bobbins as ground gear, such nets cannot be used for sampling of cod in shallower areas, and for sampling flatfish. They are however the trawls needed for a reliable sampling of herring and sprat.

Most likely it will not be possible to find a trawl in one specific size which can be towed by the smallest vessels, and which at the same time can give reliable results on the large vessels. A very small trawl used on a large vessel is difficult to handle and are not likely to give useful results.

#### **Future work of the subgroup**

The subgroup will continue the work by correspondence and - when all the information is collected - hold a meeting, - most likely in Poland or one of the Baltic States.

Due to the contrasting requirements for the new trawl it will be necessary to set up different options. The most obvious is to select two new designs of trawls, one low opening bottom trawl with small meshes for the sampling of cod in shallow water and sampling of flatfishes, and one high opening semi-pelagic trawl for sampling cod in midwater, herring and sprat. Another possibility is restricting the participating research vessels to the medium sized vessels.

The task will be to select one or more bottom trawl designs which are best suited for the tasks. The selection of the footrope is among the most important parameters to be discussed. In this context it will be considered whether a rock-hopper gear can be used in the Baltic.

The result of the work will be delivered to ICES and upon accept of the selection a manual will be worked out for the particular trawl.

Furthermore the possibility will be investigated to demonstrate the new sampling trawl in the North Sea Centre Flume Tank for biologists and research vessel crews.

Appendix 1

Research vessel				Trawl		Rigging			Doors
Nation	Name	Size M	HP	Name	Size	Footrope/ gear	Floats	Bridles/ sweeps/backstop	Type
Denmark	Dana	78	2 x 2320	Granton Expo (Startrawl, G.O.V.)		Rubber discs Plastic bobbins			Perfect 4.75 m <sup>2</sup> V-doors
Denmark	Havfisken	13	180	TV3	500 mesh in 40 mm halfmesh	Rubber gass tubes and 4" discs	13 pcs 4l	9,1 m + 36,6 m	Munkebo type 66"
Denmark	Havkatten	11	160	TV3	420 meshes in 40 mm halfmesh			9,1 m + 36,6 m	Munkebo V-doors
Germany	Solea	37	800	Sonderburg-trawl HG 20/25 Aalzeese Dorschzeese		See attached drawings			
Sweden	Argos	61.25	2 x 900	G.O.V.	acc. to ICES manual (c.m. 1992/H:I)	acc. to ICES manual except kite		-/100m	Hålså
Poland	Baltica	41	1400	HG 20/25					
Lithuania	Darius	22,44	390	For cod	29,4/34,3m		Ø300, 7-11 depends of bottomtype, floatation 10.8kg per pcs		
Latvia	Baltijas Petnieks	54,8	1160	Latvian bottom trawl,	28/33.6 m	336 # in 50 mm halfmesh			5 m <sup>2</sup>
Estonia									
Russia									
Finland	Commmer- cial vessels	15-28	350-900	Variable, depending on vessel available. German "Krabben kurre"-trawl used for 0-grong cod in early and mid 1980's (a small beam trawl).					

Large Granton, Denmark

Mesh Twine stretch Knots  
mm length sa vedge

70.0 4 11.2 4

70.0 4 8.40 4  
70.0 4 8.35 4

70.0 4 8.40 4  
70.0 4 8.40 4

70.0 4 8.40 4  
70.0 4 8.10 4

60.0 4n 8.10 4  
60.0 4n 9.00 4

60.0 6 6.00 4  
60.0 6 6.00 4

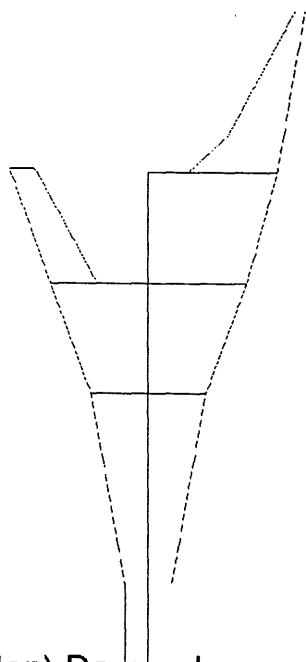

TV3, (Havfisken) Denmark

Mesh Twine stretch Knots  
mm length sa vedge

120 3/2 8.20 1

80 3/2 8.20 1

40 3/2 1.20 4

40 3/2 2.00 4

40 3/2 1.50 4

40 3/2 2.00 4

40 3/2 7.20 4

40 3/2 8.00 4

40 3/2 4.00 4

40 3/2 4.00 4

40 3/2 3.20 4

40 3/2 4.00 4

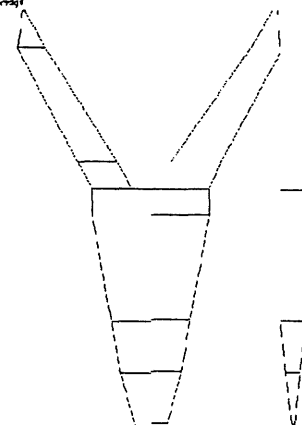

TV3, (Havkatten) Denmark

Mesh Twine stretch Knots  
mm length sa vedge

100.0 3/2 2.00 1

100.0 3/2 2.00 1

100.0 3/2 7.20 4

100.0 3/2 6.00 4

100.0 3/2 1.20 4

100.0 3/2 1.20 4

100.0 3/2 7.20 4

100.0 3/2 7.20 4

100.0 3/2 3.00 4

100.0 3/2 3.00 4

100.0 3/2 1.20 4

100.0 3/2 1.20 4

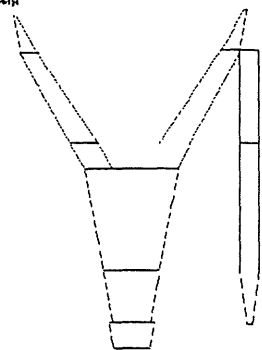

G.O.V. (IBTS survey trawl)  
Denmark, Sweden

Mesh Twine stretch Knots  
mm length sa vedge

100.0 40 nyl 8.40 1

100.0 60 nyl 8.70 1

100.0 40 nyl 7.20 4

100.0 60 nyl 7.20 4

100.0 40 nyl 6.00 4

100.0 60 nyl 6.00 4

100.0 40 nyl 2.00 4

100.0 40 nyl 2.00 4

30.0 40 ny 6.40 4

30.0 40 ny 6.10 4

60.0 32 ny 6.00 4

60.0 32 ny 6.00 4

40.0 40 ny 6.00 4

40.0 40 ny 6.00 4

25.0 32 ny 9.00 4

25.0 32 ny 9.00 4

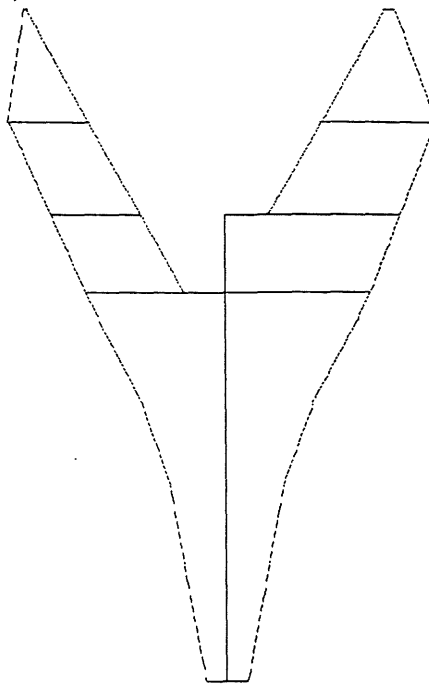

# HG 20/25 Rostock Germany Poland

Mesh Trawl stretch Knots

Mesh mm	Trawl stretch length	Knots sewedge
60.0	210/10	6.05 4
60.0	210/10	6.0 4
60.0	210/10	7.02 7
40.0	210/45	6.0 4
40.0	210/45	6.0 4
20.0	210/15	8.02 7
20.0	210/15	8.02 7
16.0	210/30	5.9 7
16.0	210/30	5.9 4

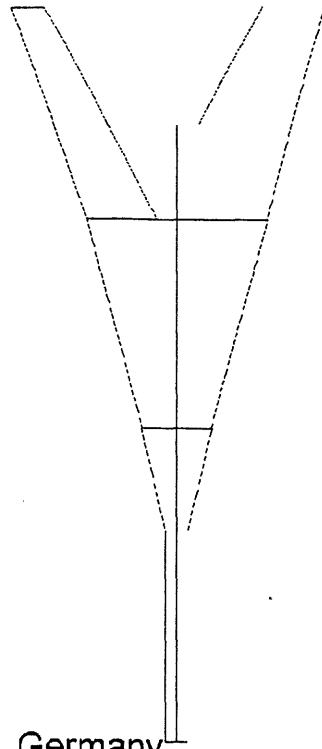

# Sonderburg, Germany, Poland

Mesh Trawl stretch Knots

Mesh mm	Trawl stretch length	Knots sewedge
60.0	210/10	6.05 4
60.0	210/10	6.0 4
60.0	210/10	7.02 7
40.0	210/45	6.0 4
40.0	210/45	6.0 4
20.0	210/15	8.02 7
20.0	210/15	8.02 7
16.0	210/30	5.9 7
16.0	210/30	5.9 4

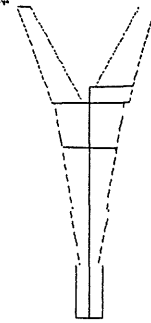

# Dorschzeese, Germany

Mesh Trawl stretch Knots

Mesh mm	Trawl stretch length	Knots sewedge
60.0	1200	7.20 4
60.0	1200	7.20 4
60.0	1200	7.20 1
60.0	1200	7.20 1
60.0	1200	7.20 4
60.0	1200	7.20 4
60.0	1200	12.2 4
60.0	1200	12.2 4
60.0	1200	13.5 4
60.0	1200	13.5 4

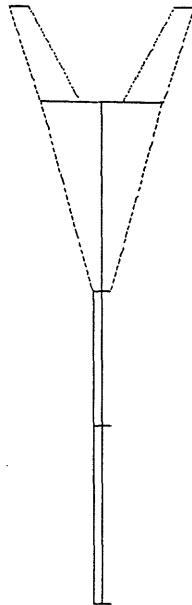

# Latvian Bottom Trawl, Latvia

Mesh Trawl stretch Knots

Mesh mm	Trawl stretch length	Knots sewedge
200.0	187-4	5.00 1
100.0	187-4	2.40 1
200.0	187-4	8.40 4
100.0	187-4	1.50 4
200.0	187-4	6.40 4
100.0	187-4	5.20 4
100.0	187-4	5.20 4
60.0	187-4	5.76 1
60.0	187-4	5.76 1
60.0	187-4	5.02 4
60.0	187-4	5.02 1
30.0	187-4	6.17 1
30.0	187-4	6.17 4

