

# ADDENDUM 1 : IBTS MANUAL - REVISION VIII

## Manual for the International Bottom Trawl Surveys

Revision VIII

The International Bottom Trawl Survey Working Group



**ICES**

International Council for  
the Exploration of the Sea

**CIEM**

Conseil International pour  
l'Exploration de la Mer

**International Council for the Exploration of the Sea  
Conseil International pour l'Exploration de la Mer**

H. C. Andersens Boulevard 44-46  
DK-1553 Copenhagen V  
Denmark  
Telephone (+45) 33 38 67 00  
Telefax (+45) 33 93 42 15  
[www.ices.dk](http://www.ices.dk)  
[info@ices.dk](mailto:info@ices.dk)

## Contents

---

<b>1</b>	<b>Introduction</b> .....	<b>1</b>
<b>2</b>	<b>IBTS Survey</b> .....	<b>2</b>
2.1	Current Objectives.....	2
2.2	History of the Survey.....	3
2.3	History of the Survey Gear.....	4
2.4	Survey Design.....	5
2.5	GOV-Trawl Construction.....	14
2.6	GOV Trawl Rigging.....	14
2.7	Standard Fishing Method.....	16
2.8	Monitoring net geometry.....	18
2.9	Fishing Positions.....	20
<b>3</b>	<b>Sampling of GOV-Trawl Catches</b> .....	<b>28</b>
3.1	Catch sorting and sampling.....	28
3.2	Length composition.....	31
3.3	Sampling for Age, Sex and Maturity.....	31
3.4	Measurement types for deep-water species.....	35
3.4.1	Smoothheads and Searsids (Alepocephalidae and Searsidae).....	35
3.4.2	Grenadiers (Macrouridae)- PAFL – Pre Anal Fin Length.....	36
3.4.3	Chimaeridae (Rabbitfish) – PSCFL – Pre Supra Caudal Fin Length.....	37
<b>4</b>	<b>Methot Isaac Kidd Net</b> .....	<b>37</b>
4.1	Construction and Rigging.....	37
4.2	Fishing Method.....	37
4.3	Sample and Data Treatment.....	38
4.4	Calibration of the Flowmeter.....	39
4.5	Allocation of Rectangles.....	39
<b>5</b>	<b>Environmental data</b> .....	<b>43</b>
<b>6</b>	<b>Exchange specifications for IBTS data</b> .....	<b>43</b>
	<b>Appendix Ia: Chronology of the International Bottom Trawl Survey</b> .....	<b>51</b>
	<b>Appendix Ib: History of the North Sea IBTS Surveys</b> .....	<b>53</b>
	<b>Appendix II: IBTS Standard Gear Check sheet 1</b> .....	<b>55</b>
	<b>Appendix III: IBTS Standard Gear Check sheet 2</b> .....	<b>56</b>
	<b>Appendix IV: IBTS Standard Gear Check sheet 3</b> .....	<b>57</b>

Appendix Va: IBTS Standard Gear Check sheet 4 – Ground Gear A.....	58
Appendix Vb: IBTS Standard Gear Check sheet 4 – Ground Gear B.....	59
Appendix VI: Catch sampling summary for North Sea IBTS quarter 1 surveys .....	60
Appendix VII: Catch sampling summary for North Sea IBTS quarter 3 surveys .....	61
Appendix VIII: Finfish Maturity Key .....	62
Appendix IX: Four Stage Maturity Key for Skates and Rays ( <i>Rajidae</i> ) .....	64
Appendix X: Haul Information.....	65
Appendix XI: Length Frequency Information.....	67
Appendix XII: SMALK.....	68
Appendix XIII: Area Type Codes: Sampling Areas and Standard Areas for the Calculation of Abundance Indices .....	69
Appendix XIV: Length Splits Used to Provide Preliminary Numbers at-age.....	69

## 1 Introduction

The International Bottom Trawl Survey Working Group, formerly known as the International Young Fish Survey Working Group, has the responsibility of coordinating various research vessel surveys conducted within certain ICES areas. The first survey to be coordinated was the International Young Fish Survey (IYFS) that was conducted in the North Sea and Skagerrak/Kattegat in February of each year starting in the late 1960's. A procedural manual was produced for the use of scientists involved in this survey and subsequently two revised editions were produced as international cooperation developed. In 1991 this co-operative programme was expanded to include the three other quarters in the North Sea and Skagerrak/Kattegat. This necessitated major alterations to the manual and the revised edition was published as ICES CM 1992/H:3.

During the Annual Science Conference in St John's, Newfoundland in 1994 the recommendation was made that the International Bottom Trawl Survey Working Group should also incorporate the coordination of bottom-trawl surveys in ICES Sub-Areas VI, VII and VIII and Division IXa (these areas are designated as the western and southern areas).

In 1995 the manual was revised for a fifth time in order to clarify certain aspects of the surveys in the North Sea and Skagerrak/Kattegat. At the same time the opportunity was taken to review the manual to establish whether the same procedures could be applied to Sub-Areas VI, VII and VIII and Division IXa. It was decided that some aspects of the manual applied equally to all areas but some procedures required dedicated text. At the same time it was decided that a manual for the western and southern areas required further discussion and input from countries closely associated with these areas but who were unable to attend the meeting. Consequently procedures unique to the western and southern areas were provided in Appendix XI, of the fifth revision, as a draft awaiting approval by all participants.

At the IBTS Working Group meeting in 1999 (Lisbon 7–10 April) it became apparent that a single manual covering such an extensive area was inappropriate. As corrections and amendments were outstanding for the North Sea IBTS Manual, the opportunity was taken to revise the document (the sixth revision).

A separate manual for the western and southern waters was originally produced for the IBTS meeting in Dublin, in 2002, but has been updated in 2010 and is available separately. Also during 2002 other major revisions were required to the North Sea manual (the seventh revision) and these were completed in 2004. Table 1.1 gives the history of the survey manual creation for the IBTS North Sea surveys.

**Table 1.1 History of North Sea Survey Manuals revisions.**

YEAR OF PUBLICATION	VERSION	SURVEY NAME	REFERENCE
1978	I	North Sea Young Fish Surveys	Manual for the ICES North Sea Young Fish Surveys, 1. edition. A. Corten (Ref. #/ citation unknown)
1981	II	International Young Fish Survey (IYFS)	Manual for the International Young Fish Surveys in the North Sea, Skagerrak and Kattegat. ICES CM 1981/H:9
1986	III	IYFS	Manual of the International Young Fish Survey in the North Sea, Skagerrak and Kattegat, third revision. ICES CM 1986/H:2

YEAR OF PUBLICATION	VERSION	SURVEY NAME	REFERENCE
1992	IV	IBTS	Manual for the International Bottom Trawl Surveys. Revision IV, Addendum to ICES CM 1992/H: 3
1996	V	IBTS	Manual for the International Bottom Trawl Surveys. Revision V, Addendum to ICES CM 1996/H:1
1999	VI	IBTS	Manual for the International Bottom Trawl Surveys. Revision VI, ICES CM 1999/D:2
2004	VII	IBTS	Manual for the International Bottom Trawl Surveys. Revision VII, ICES CM 2006/RMC:03
2010	VIII	IBTS	Manual for the International Bottom Trawl Surveys. Revision VIII # citation not yet available

This manual seeks to describe the survey and its history, paying particular attention to the current gears and practises in place. Description of gears, areas covered and data collected is described in detail along with information helpful to anyone participating in the surveys or interested in them.

## 2 IBTS Survey

### 2.1 Current Objectives

IBTSWG coordinates fishery-independent multi-species bottom-trawl surveys within the ICES area. These surveys aim to provide ICES assessment and science groups with consistent and standardized data for examining spatial and temporal changes in (a) the distribution and relative abundance of fish and fish assemblages; and (b) of the biological parameters of commercial fish species for stock assessment purposes.

In terms of groundfish surveys coordinated by IBTS, the main objectives are to:

- 1) To determine the distribution and relative abundance of pre-recruits of the main commercial species with a view of deriving recruitment indices;
- 2) To monitor changes in the stocks of commercial fish species independently of commercial fisheries data;
- 3) To monitor the distribution and relative abundance of all fish species and selected invertebrates;
- 4) To collect data for the determination of biological parameters for selected species;
- 5) To collect hydrographical and environmental information;
- 6) To determine the abundance and distribution of late herring larvae (February North Sea survey).

For a survey to be considered to be coordinated under IBTSWG it should fulfil the following criteria:

- a) To be carried out in the ICES areas IIIa, or IV-IX.
- b) A brief outline of the management need/context for the survey should be provided by an ICES assessment working group;
- c) It is an otter trawl survey, but noting that there may be other working groups better placed to coordinate some bottom trawl surveys;
- d) The survey either has appropriate sampling methods and protocols (including gear descriptions) that conform to the standards encouraged by the IBTSWG, or that can be improved after joining IBTSWG;

- e) The survey should aim to enhance existing IBTS surveys and improve data collection for important stocks. For example, proposed surveys for inclusion within IBTSWG should (i) overlap and extend existing survey areas using a comparable gear, or (ii) operate on more specific grounds/times of year with a gear more appropriate for the target species;
- f) Store their data in the DATRAS database, and participate in data quality checking;
- g) Attend and present data at the annual meetings of IBTSWG;
- h) Assessment working groups should confirm (e.g. after a five year period) that any surveys targeting specific stocks and not using gears used in the standard IBTS surveys are still providing data of high quality that are used for assessment and provision of advice.

## 2.2 History of the Survey

The following account has been adapted from Heessen *et al.* (1997).

In spring and autumn of the years 1960 and 1961 a series of four large international research vessel trawl surveys were organized under the auspices of ICES, to map the distribution of juvenile herring *Clupea harengus* in the North Sea and to investigate the links between herring nursery grounds and the adult populations (ICES, 1963).

In the following years most of the countries participating in the former exercise continued similar surveys. From 1966 onwards these surveys were conducted annually with the objective of obtaining annual recruitment indices for the combined North Sea herring stocks. Gradually more countries started to participate in the survey, which was named the International Young Herring Survey (IYHS). For the first few years, sampling was restricted to the southern and central North Sea and, beginning in 1969, the Skagerrak and Kattegat.

Although the emphasis from the start of the surveys focused mainly on herring, data collected for whiting *Merlangius merlangus* were also analysed. In the course of the 1970s it was realized that the IYHS could provide recruitment indices not only for herring, but also for roundfish species such as cod *Gadus morhua*, haddock *Melanogrammus aeglefinus* and whiting. This growing interest resulted in a northwards extension of the survey area to cover the entire distribution of juvenile haddock in the North Sea, and also that of Norway pout *Trisopterus esmarki*. The whole North Sea, Skagerrak and Kattegat have been surveyed since 1974.

In 1981 the survey was renamed the International Young Fish Survey (IYFS), the first manual was produced (ICES, 1981b), and in 1984 the ICES 'Working Group on Young Herring Surveys' and the 'Gadoid 1-Group Working Group' were combined to form the International Young Fish Survey Working Group.

In 1990 the IYFS Working Group evaluated the usefulness of a number of bottom-trawl surveys in the North Sea, Skagerrak and Kattegat (ICES, 1990). Apart from the international IYFS, these surveys were comprised of at least seven national surveys. The IYFS WG proposed to combine the IYFS and the national surveys in Quarterly Coordinated Surveys in the North Sea, Skagerrak and Kattegat, which were to be called the International Bottom Trawl Surveys (IBTS). It was recommended that quarterly surveys should run for a period of five years. These surveys should provide a full description of the seasonal distribution of the stocks sampled, which was considered urgently necessary for the further improvement of multispecies assessments and the development of spatially disaggregated assessment models.

This proposal resulted in a series of six years with quarterly surveys, which, with a few exceptions, covered the whole survey area in the North Sea, Skagerrak and Kattegat (ICES, 1996a). Subsequently, it has proven impossible to maintain these high levels of research vessel effort, especially as research budgets have decreased in most countries and, from 1997, the majority of countries have only carried out a survey twice a year; a first quarter survey (January-February) and a third quarter survey (August-September).

Appendix Ia shows the timeline of significant events in the history of the IBTS and appendix Ib shows the history of the how the surveys have been carried out.

Having evolved from a herring survey, when only pelagic data were collected, the IBTS survey dataset is now made up of data collected on all finfish species. However, this current level of sampling has evolved gradually. In the manual revision VI, sampling was defined by two groups, 'standard' and 'closed bycatch'. Because all participants now sample all finfish species in one way or another, these have not been defined in this revision.

Coverage of the whole survey area was almost complete from every quarter of the years 1991-1996. In quarters 2 and 4 in 1997, however, the total effort was at a much lower level and limited to the contributions of a few nations. Since 1997, the surveys have been conducted in quarters 1 and 3, only.

Starting in 2006, the French in quarter 1 started to carry out additional tows in the Eastern English Channel as part of the standard IBTS survey. This proved successful and starting in 2007 the RV 'Thalassa' carried out 8 GOV trawls and 20 MIK stations. During the IBTSWG in 2009, Roundfish Area 10 was created to cover these new stations fished by France and the Netherlands.

Since the beginning of the century, a number of countries have noted that the gear parameter tables within the historical North Sea IBTS survey manuals had been difficult to adhere to when trawling. Between 2007 and 2010, analysis has been carried out to assess whether new tables or a new definition of the standard parameters for towing were needed. Ultimately during the 2010 working group it was decided that the standard tow would be re-defined in terms of achievable gear parameters. In this revision of the manual the old warp out to headline height and doorspread plots should be used as a guide for optimum gear geometry (Figures 2.10, 2.11 and 2.11).

### **2.3 History of the Survey Gear**

Before the IBTS was coordinated fully, there were many survey gears used. In 1960 the Netherlands used a Dutch Herring Trawl; in 1966 Germany started a survey in the North Sea and used a Herring Trawl. In 1967, UK (England) and UK (Scotland) join in and used the Dutch herring Trawl. By 1969, three different rigged Dutch Herring trawls and one Herring Trawl were being used in the North Sea to carry out the herring surveys. As the surveys moved away from concentrating on just herring, there was a move away from the herring trawls to a more multipurpose gear. In 1976 six different survey gears were being used by eight different nations. Then, in 1978, one multipurpose gear started to be used by more and more nations, and by 1983 all nations participating in the quarter 1 IYFS were using the GOV 36/47, albeit with slightly different rigging configurations of the sweep lengths. Since then, the GOV has been the recommended standard gear of the IBTS. By 1992, the GOV was used in all quarters of the IBTS.



## 2.4 Survey Design

The stratification of the survey grid has always been based on ICES statistical rectangles of roughly 30 x 30 nautical miles (one degree longitude x 0.5 degree latitude). Each rectangle is usually fished by the ships of two different countries, so that typically, at least two hauls are taken per rectangle.

The design of the quarter 1 survey has gradually changed over the years. In 1974 the survey was still very much a herring survey (ICES, 1974). In that year the IYHS WG decided to use three strata, which depended on the amount of herring caught in the former years. This would result in all 214 hauls. After some years this system was dropped and for several years four hauls per rectangle were made in the south-eastern North Sea, the most important area for juvenile herring (between 50°30' and 57°N, and 4° and 8°E), and two hauls per rectangle in the remaining area. In 1991, at the start of the quarterly surveys, part of the research vessel effort from quarter 1 was shifted to the other quarters and from that year on the target was to make at least two hauls per rectangle over the whole survey area.

The allocation of stations to IBTS participants has changed slightly over the years. The latest main reallocation occurred in 1991, but it was then tried to keep at least one vessel in every subarea, which had fished there over the most recent years. A typical allocation of the different vessels during the quarter 1 survey is shown in Figure 2.1, and quarter 3 surveys in Figure 2.2.1 to 2.2.7.

For the other quarters three different grids were introduced (ICES, 1990): the 'coarse' grid based on the routine in the English Groundfish Surveys which covers half of the rectangles in the North Sea, the 'complementary coarse grid' covers the other half, and a grid that consists of all the neighbouring rectangles in a certain area (as used for example in the Scottish Groundfish Surveys). The idea was that in every quarter at least 4 vessels should participate: one vessel should fish the coarse grid, one the complementary coarse grid; one should fish all the rectangles in the southern half of the North Sea and one in the Northern half. In this way all rectangles should be fished twice, by two different vessels. As discussed above, only the quarter 3 surveys have had this coverage since 1997.

Initially one-hour hauls were made, but in 1976 with gadoid outburst contributing to increased catches and in order to allow for the opportunity to carry out more hauls in a day some participants changed to 30-minute tows. This was then made a recommendation at the Working Group in 1977 and all countries (with the exception of Scotland) reduced the standard haul duration to 30 minutes during the surveys in 1978. The Scottish institute continued to make one-hour hauls until 1998 when they changed to a new vessel and standardized to 30 minutes.

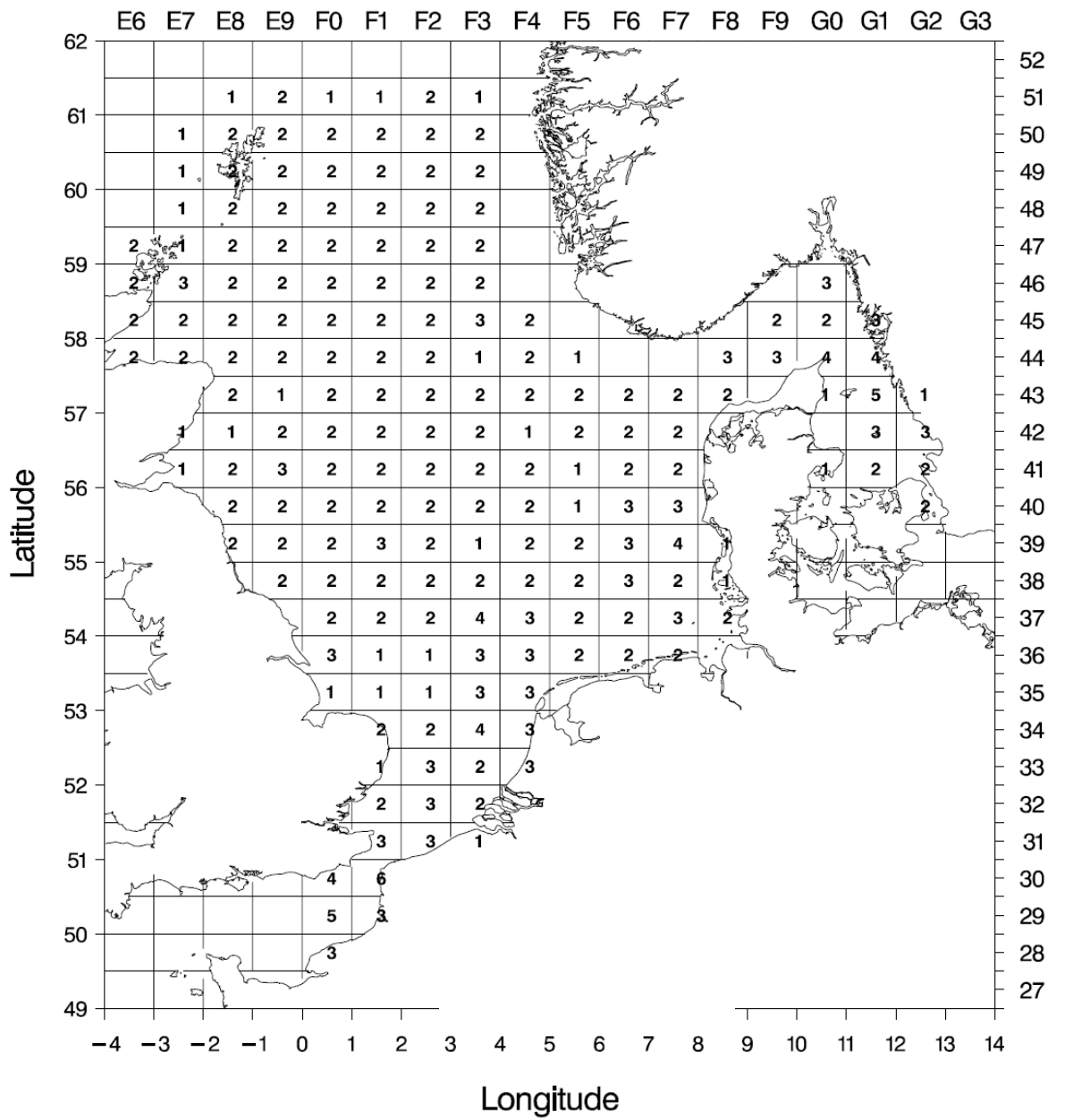

Figure 2.1. IBTS Quarter 1 Proposed Survey Grid All Participants.

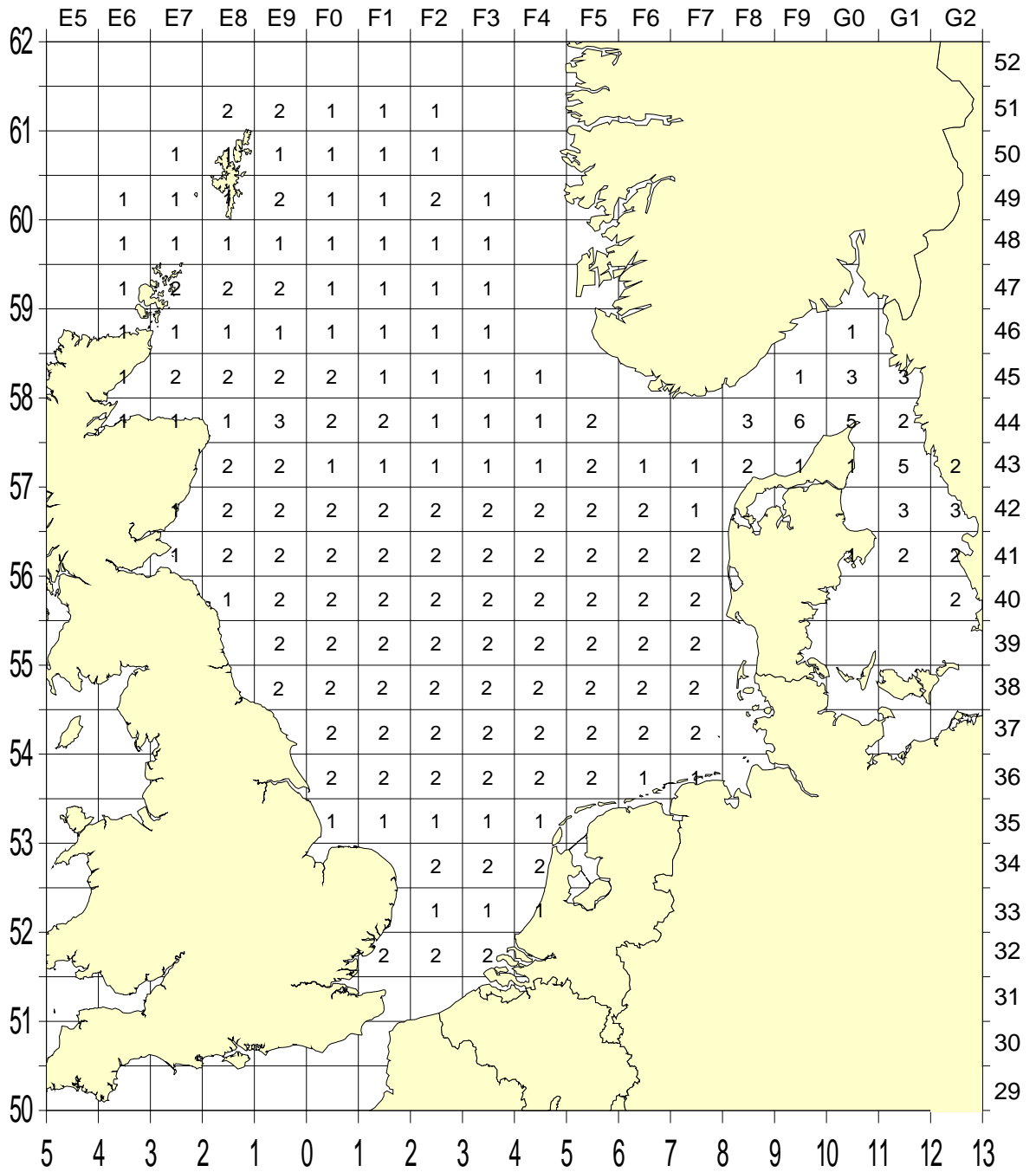

Figure 2.2.1. IBTS Quarter 3 Proposed Survey Grid All Participants.

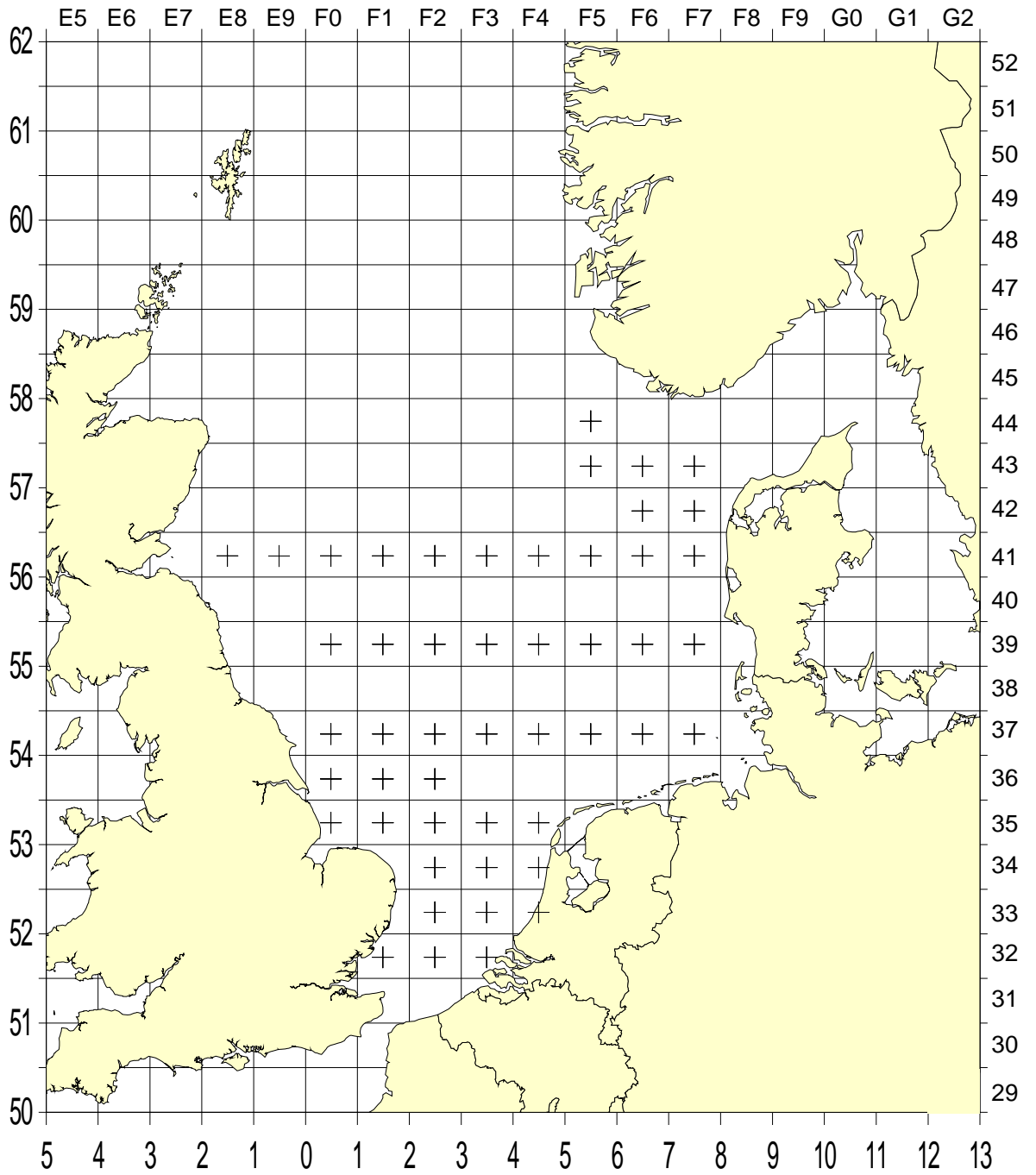

Figure 2.2.2. IBTS Quarter 3 Proposed Survey Grid – Denmark.

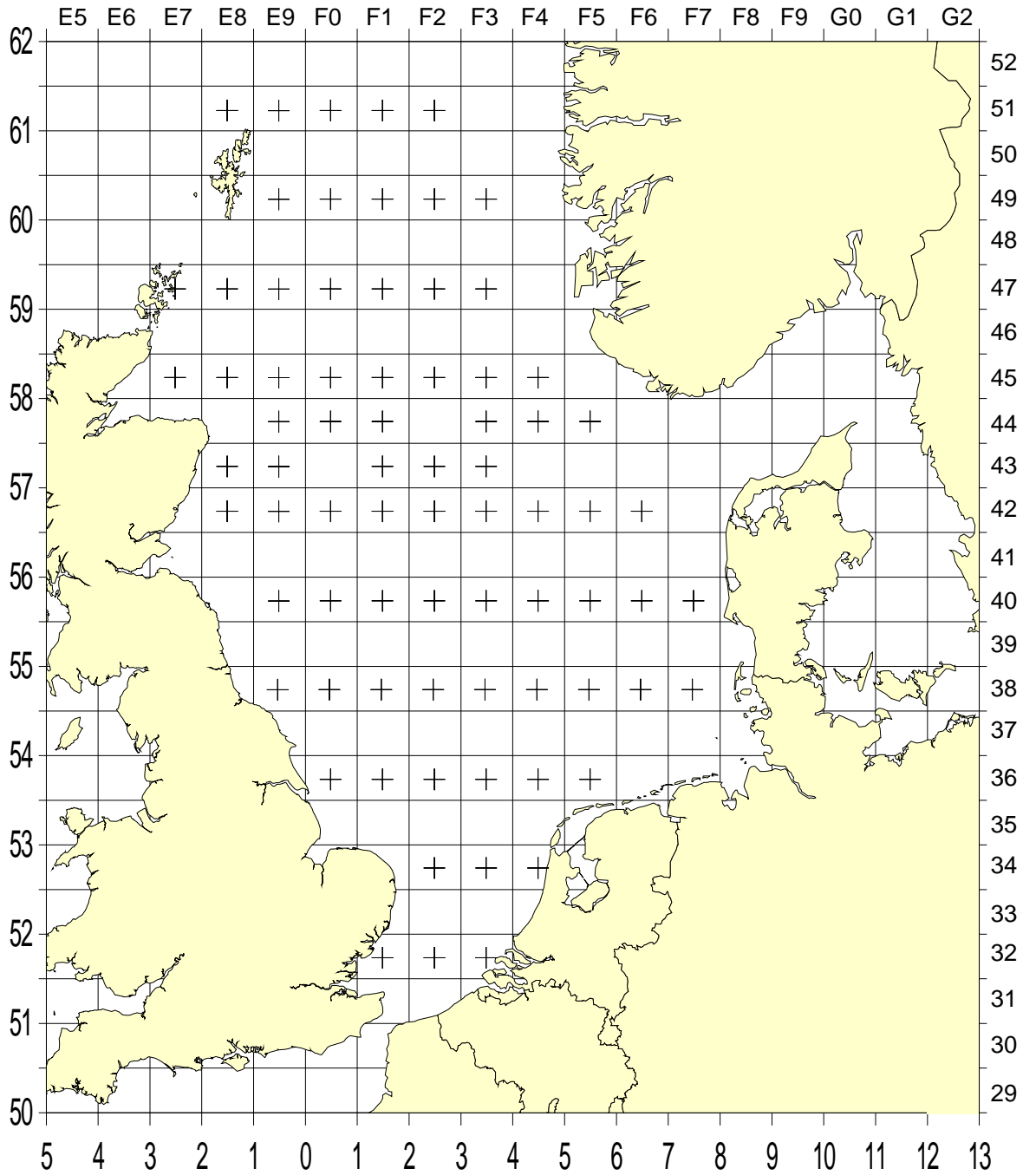

Figure 2.2.3. IBTS Quarter 3 Proposed Survey Grid – England.

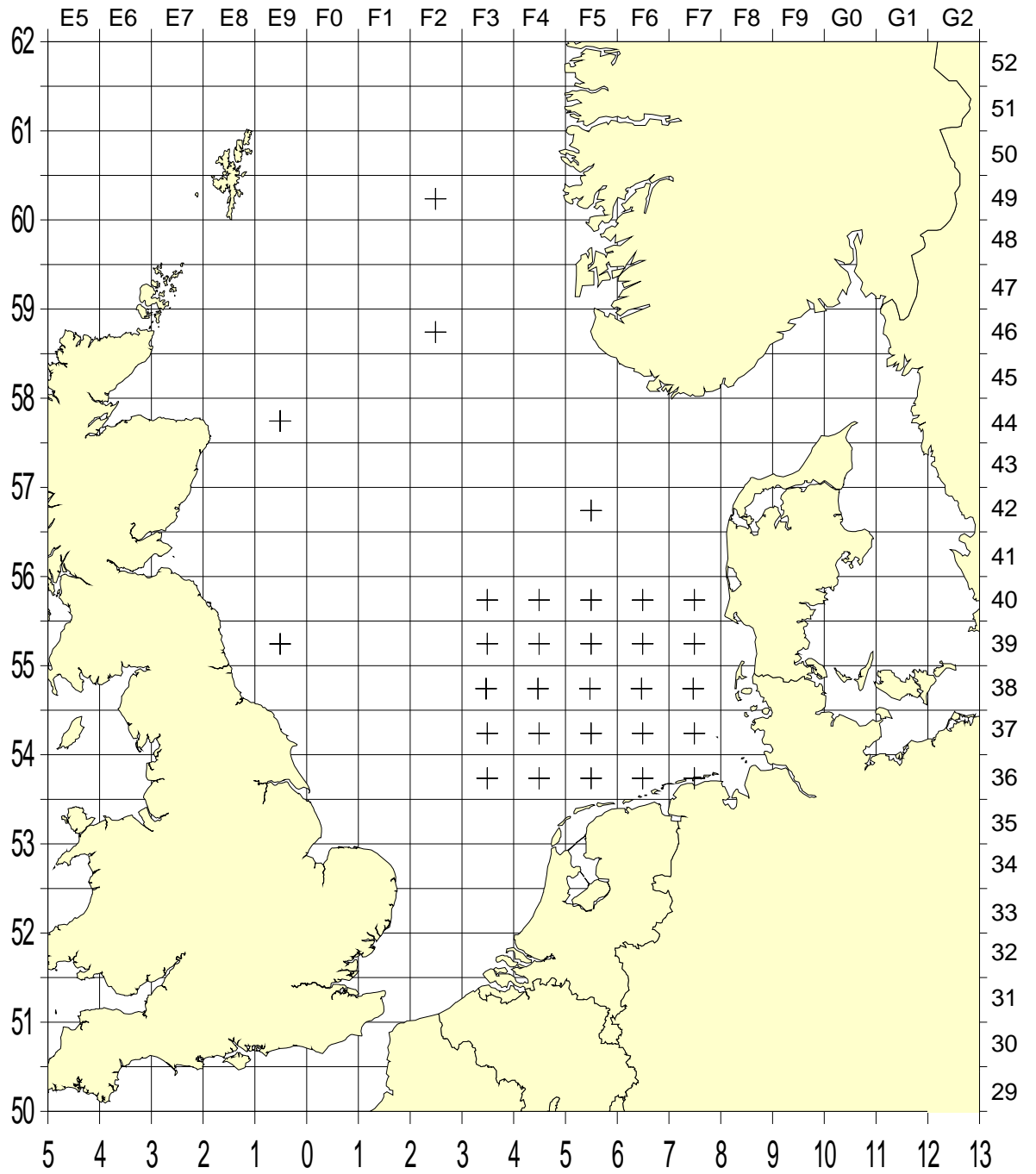

Figure 2.2.4. IBTS Quarter 3 Proposed Survey Grid – Germany.

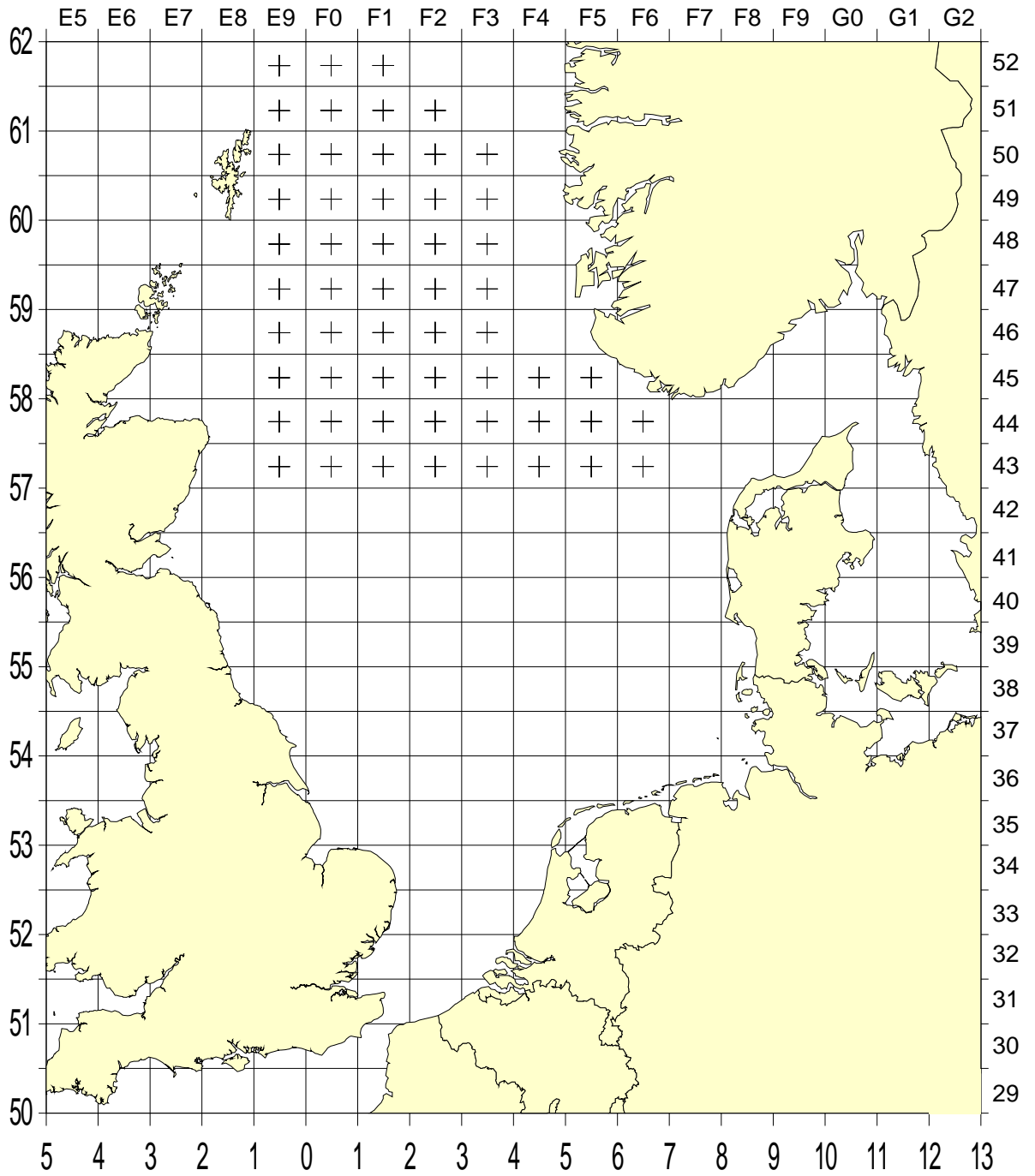

Figure 2.2.5. IBTS Quarter 3 Proposed Survey Grid – Norway.

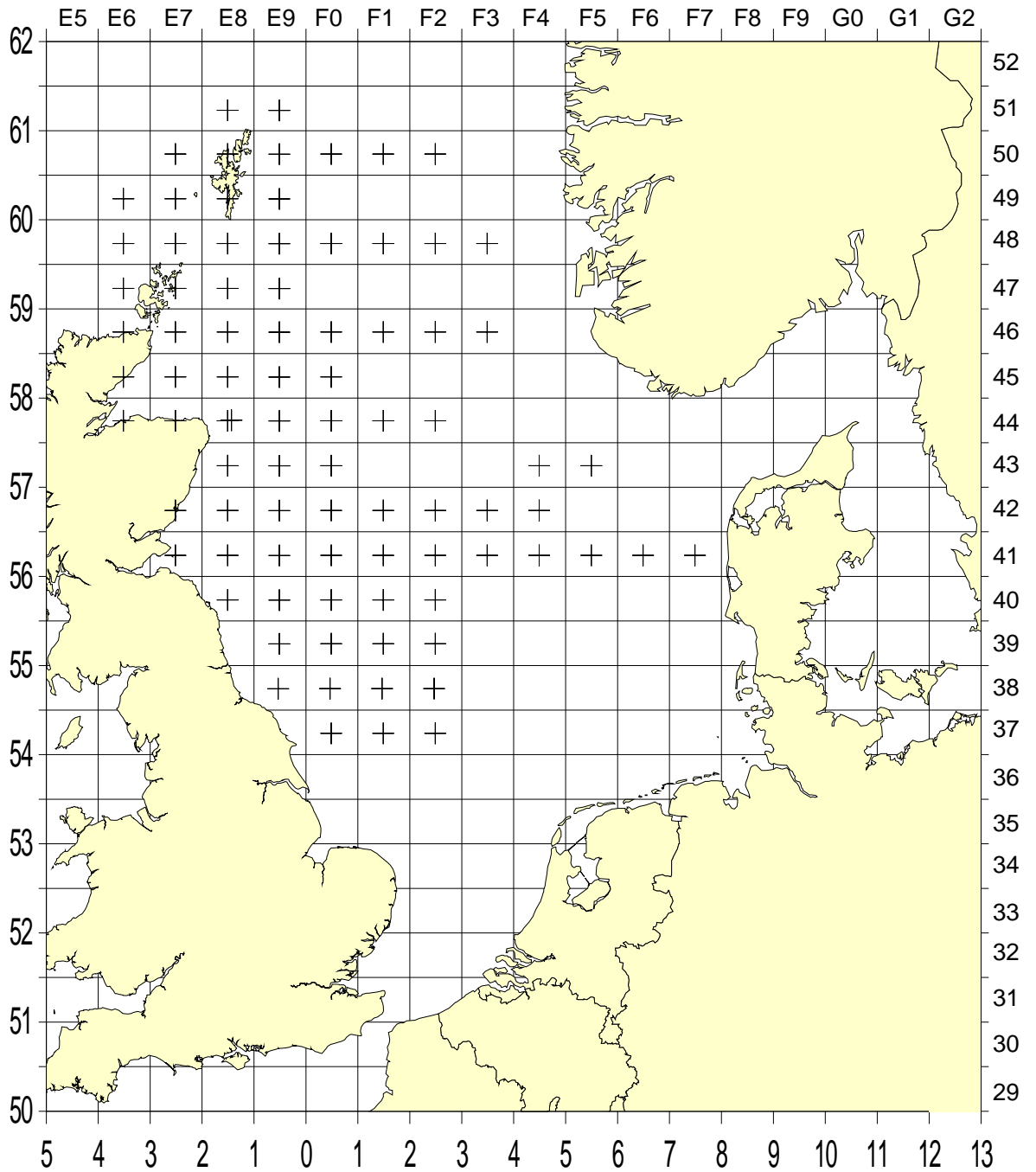

Figure 2.2.6. IBTS Quarter 3 2004 Proposed Survey Grid – Scotland.



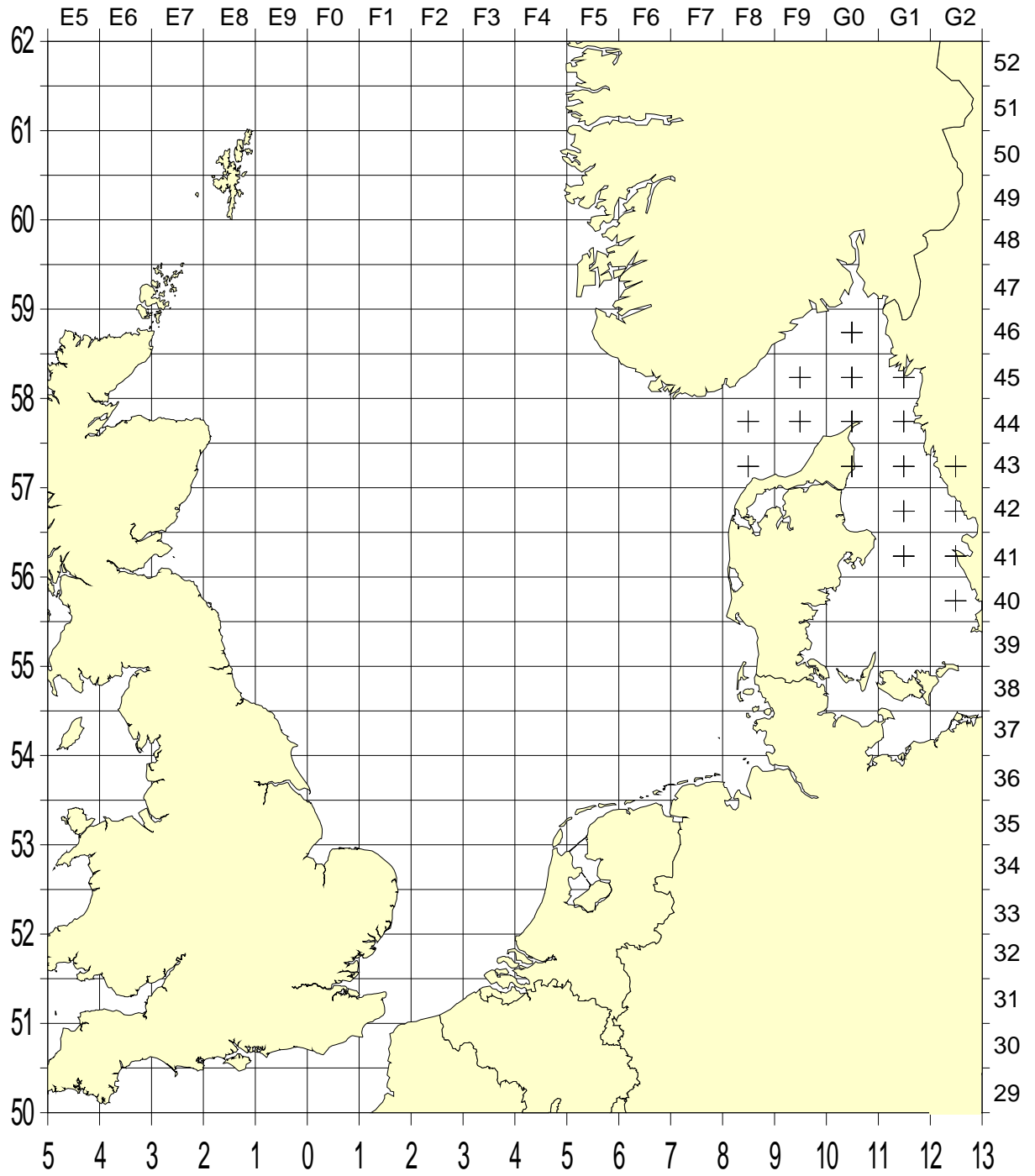

Figure 2.2.6. IBTS Quarter 3 2004 Proposed Survey Grid – Sweden.

## 2.5 GOV-Trawl Construction

The construction of the 36/47 GOV-trawl is shown in Figure 2.5. A set of check sheets should be used to maintain a standard rigged GOV. These should be used to check all dimensions of the GOV and to ensure that it is rigged correctly on the vessel. When a new net is delivered check sheets 1 (Appendix II) and 2 (Appendix III) should be filled in to ensure that the net is manufactured to the correct specification.

Special attention is drawn to the lining of the codend. This lining should consist of 400 stretched meshes of 20 mm each, giving a total length of 8m. The total circumference of the lining should be 600 meshes.

Details of the "Exocet" kite and suggestions how to attach the kite to the trawl are shown in Figure 2.6. Five floats with a buoyancy of 2.9 kg each should be attached to the kite. If a kite other than the recommended one is used then the lift of this kite should be the same as of the "Exocet" kite so that the configuration of the net conforms to expected parameters. Figures 2.11 and 2.12 illustrate the expected warp out / headline height ratio and the warp out / door spread ratio.

Total buoyancy of the floats on the net should be 172 kg. The floats should be spread as evenly as possible over the wings and the square.

## 2.6 GOV Trawl Rigging

The rigging is given in Figure 2.7. On board the vessel when attaching the trawl to the bridles and doors, check sheet 3 (Appendix IV) should be used.

Historically during the first quarter survey the length of the sweeps should have depended on the bottom depth:

- 60m sweeps (including back-strops) are used in water depths less than 70 m,
- 110m sweeps (including back-strops) are used in deeper waters.

However in Q1 not all countries are carrying out these changes. It should be noted that the most important consideration is that the **net geometry is within the acceptable limits** for the depth of water.

In Q3, a sweep length of 60 m (including back-strops) is used throughout the survey area. The different sweep lengths in Q1 were kept for reasons of consistency over the time-series. The effect of the different sweep lengths was, however, doubted and therefore not copied when the quarterly surveys started in 1991.

The standard groundrope with rubber discs (groundgear 'A') as shown in Figure 2.8 should be used throughout the survey area. However, since 1985 Scotland have used a hard groundgear 'B' on all stations north of 57° 30" North (Figure 2.9). Again a check sheet (Appendix Va and Vb) should be used to ensure the groundgear is to specification. The extra weights in the groundrope are 70 kg in the square, 35 kg in each quarter and 35 kg in each forward wing-end. These weights should be evenly spread over the appropriate length of groundrope and this can be achieved by wrapping chain externally around the groundrope or, preferably, by interspersing the groundrope rubber discs with steel discs of the same diameter. Approximate weight in air is given for each section of the groundrope.

It is very important to achieve good bottom contact over the whole groundrope and this should be checked regularly. A proper contact of the net could be indicated by acoustic devices, wearing on chains and presence of benthic organisms and flatfish in

the catch. The contact of the net with the bottom can also be greatly influenced by changing the length of the adjustment chain between the lower leg and the bumper bobbin. The normal length of this chain is 2 metres but on rough ground it can be shortened to 1.7 metres; if the gear is fishing too light it can be lengthened to 2.2 metres.

For a proper performance of the net it is essential that the four upper bridles are of identical length, and regular checks should be made to ensure this. It is also recommended that a total check of the trawl is carried out prior to the survey.

When checking the GOV mesh sizes, either during construction or on rigging the net, either an Omega net gauge or another standard net gauge should be used, measuring the stretched mesh (see figure below).

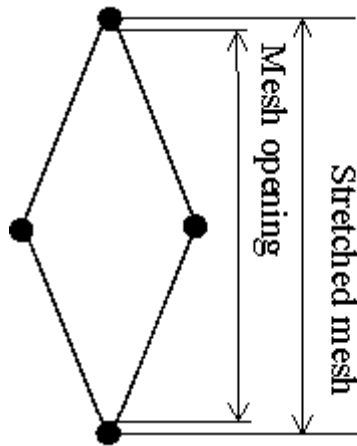

During measuring a 5% tolerance is allowed. When using the Omega Gauge, please follow the manufacturers' instructions for correct use, as overstretching could be an issue. The net can be measured either wet or dry. This is a summary of the information taken from the working document presented at IBTSWG in 2008 (WD1: Mahé, J.C., Mortreux, S. 2008 – Review of measurement protocols for mesh size and effect of intensive use on the initial characteristics).

The following flow diagram (Figure 2.3) can be used to describe the procedure for the preparation of the GOV trawl prior to the survey and each haul.

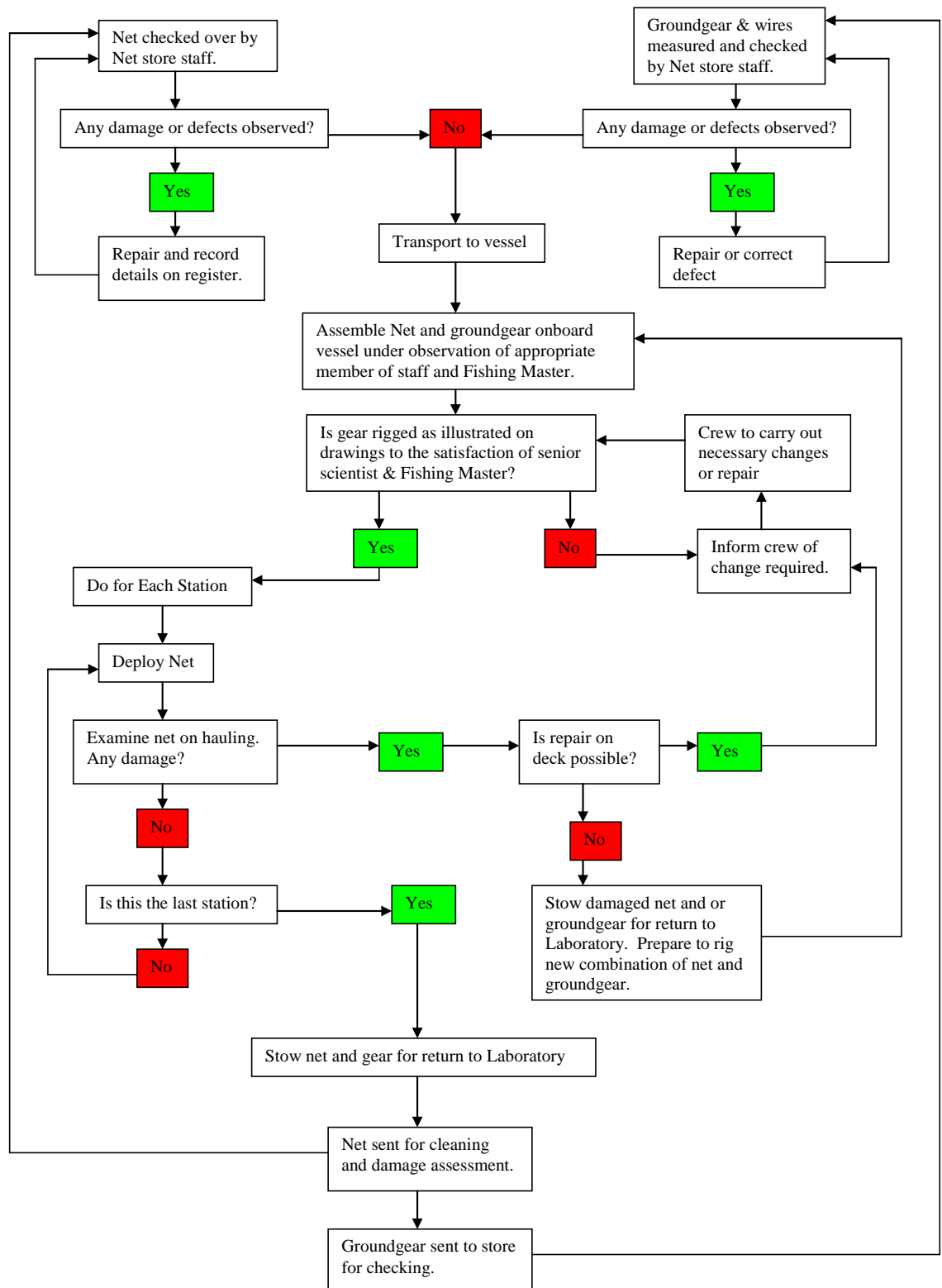

Figure 2.3. IBTS GOV preparation flow diagram.

## 2.7 Standard Fishing Method

It is suggested that all nations undertaking standardized surveys allocate some of the survey time to carrying out additional hauls at the start of the survey with the specific aim of ensuring that all standard elements of the groundfish survey are working correctly. This should include:

- Gear deployment: is the gear rigged correctly and being deployed and retrieved appropriately by the crew? Is the deck machinery all functioning?
- Ground contact: do the groundgear and doors indicate that the net is on the bottom and fishing correctly?
- Trawl sensors and CTDs: are all electronic equipment functioning correctly, and collecting meaningful data?
- Catch processing: are all elements of catch processing and data inputting functioning?

Though there are good reasons for having these additional hauls in the main survey area, for practical reasons they should be undertaken near the port of departure. This would then allow additional staff (including a gear technologist) to be present to fully check the gear and electronics, and would also save time in case something requires further attention.

Standard fishing speed is 4 knots measured as trawl speed over the ground. The recommended speed is set as a target and actual (ground) speed and distance towed should be monitored and reported. With tide and weather effecting the average speed of a vessel, as a guide the minimum trawl speed should not go below 3.5 knots and the maximum should not exceed 4.5 knots with the average for the entire tow being as close to 4 knots as possible. It is also recommended that if possible, the speed of the trawl through the water should be monitored and reported.

A standard tow should be fished for 30 minutes. Start time is defined as the moment when the vertical net opening and doorspread are stable. Stop time is defined as the start of the winches hauling the net back in. It may be acceptable to fish for less than this i.e. haul early for safety reasons or for very large catches, however any tow under 15 minutes should be either invalid or tagged as non-standard and reasons given for it.

As a minimum, vertical net opening and doorspread should be monitored at 30-second intervals and after appropriate filtering for invalid values the mean values should be reported. It is recommended that wingspread is also measured. In order to ensure that the gear performs correctly the net geometry should be within tolerances set out in Section 2.8.

It is preferable to only conduct trawling operations during daylight hours although it is recognized that some institutes may wish to trawl both during the day and night. Night-time hauls need to be entered as such and should not be used as standard IBTS hauls for direct comparison with daylight hauls. It is further strongly recommended that during the February survey the trawling in the old herring standard area (see Figure 6.4) is carried out during daytime only. In the morning the net should not be shot earlier than 15 minutes before sunrise. At the end of the day, the net must be hauled within 15 minutes after the time of sunset. A software package that calculates sunrise and sunset, called "RiseAndSet", is available from IMARES, but many other are available and may be used. In order to make a quick calculation, the daylight hours for various periods can be calculated with reference to current latitude and the text table below:

Daylight period in UTC at 0 degrees longitude:

Dates		South of 57° 30' N			North of 57° 30' N		
		Sunrise		Sunset	Sunrise		Sunset
01-10	Jan	08.09	-	15.58	08.45	-	15.25
10-20	Jan	08.01	-	16.17	08.31	-	15.45
21-31	Jan	07.47	-	16.35	08.15	-	16.07
01-10	Feb	07.29	-	16.58	07.49	-	16.36
11-20	Feb	07.08	-	17.20	07.23	-	17.05
21-28	Feb	06.47	-	17.41	06.55	-	17.30
01-10	Mar	06.27	-	17.57	06.32	-	17.50
11-20	Mar	06.03	-	18.18	06.05	-	18.15
21-31	Mar	05.35	-	18.38	05.32	-	18.39
01-10	Jul	03.15	-	20.55	02.28	-	21.40
11-20	Jul	03.26	-	20.47	02.49	-	21.24
21-31	Jul	03.41	-	20.33	03.08	-	21.03
01-10	Aug	04.00	-	20.12	03.34	-	20.38
11-20	Aug	04.19	-	19.50	03.59	-	20.09
21-31	Aug	04.37	-	19.26	04.23	-	19.42
01-10	Sep	04.57	-	19.00	04.48	-	19.09
11-20	Sep	05.16	-	18.34	05.12	-	18.38
21-30	Sep	05.35	-	18.08	05.35	-	18.08

Source: 'The Times Atlas' 1972, p 33.

For each degree longitude west, 4 minutes should be added and for each degree longitude east, 4 minutes should be subtracted.

## 2.8 Monitoring net geometry

All countries should use electronic equipment to monitor net geometry (e.g. SCANMAR). On all IBTS hauls, headline height and door spread should be recorded. The sensor manual should be referred to for the correct method for attaching the units to the gear. In order to ensure a valid tow, gear stability is crucial. In the first instance, the new warp out to depth ratios should be used to control net geometry. **During the tow it is imperative that net geometry is measured and kept within the acceptable limits** (Figure 2.10, Figure 2.11 and Figure 2.12 should be used as a guide until new updated plots can be produced). The user should continuously monitor net performance during a tow and if needed adjust the trawling conditions to return to accepted limits (e.g. by changing warp length). If the readings remain outside the recommended values for an unacceptable period of time it could mean that the gear has become fouled or damaged and should be hauled in.

It is recommended that the entire data stream, including all the net sensor parameters that are recorded, is saved to allow mean values to be calculated properly and entered into the individual institutes' databases. These values should be calculated from the time the gear has stabilized on the bottom to the time the gear is hauled. Data screening should also be carried out, and the 2009 SGSTS report Section 4.2.1, gives guidance on how to carry this out.

The following flow diagram (Figure 2.4) can be used to help in the process of using software for net performance sensors and units during a GOV haul.

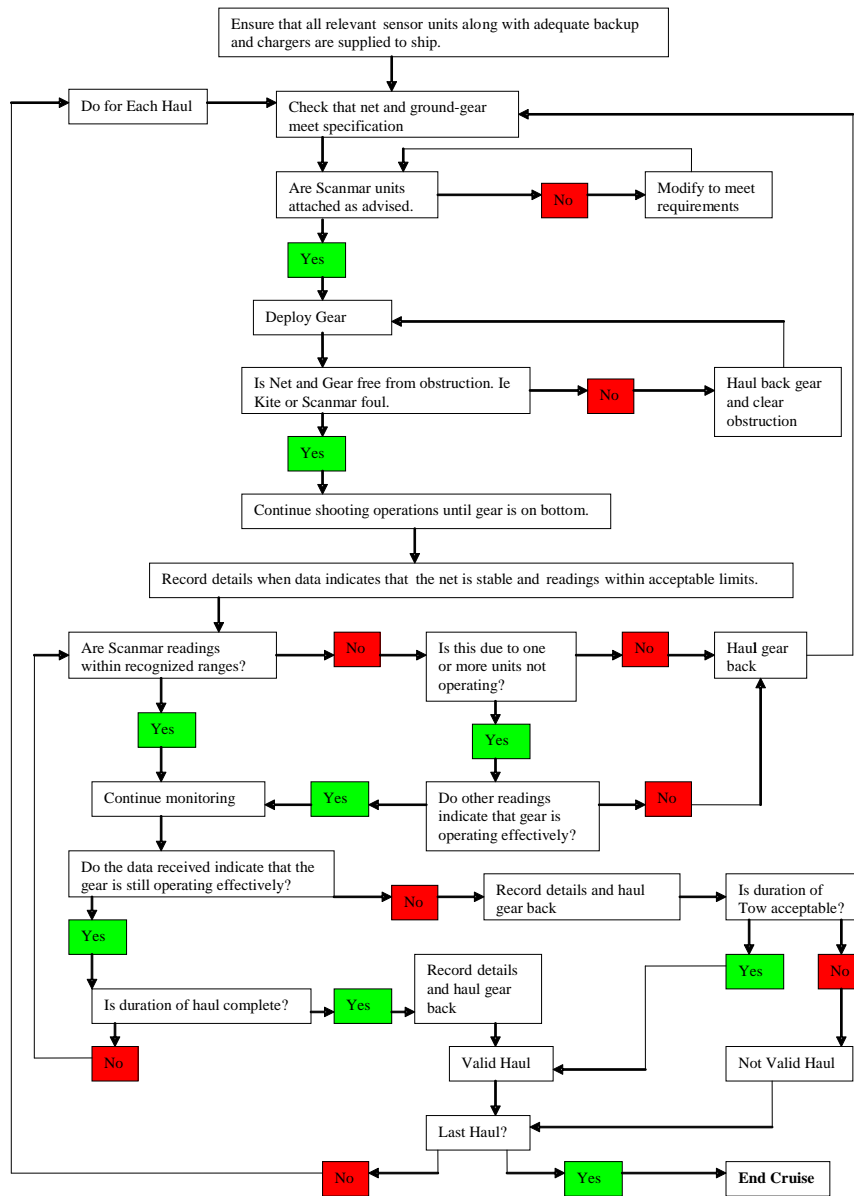

Figure 2.4. IBTS flow diagram for use of data from net performance sensors.

## 2.9 Fishing Positions

Most statistical rectangles contain a number of possible tows that are deemed to be free of obstruction. In some rectangles sampling may be further stratified due to significant changes in seabed depth, which may, in turn, cause variations in the fish population. Vessels are free to choose any positions in the rectangles that they are surveying if hauls are sufficiently far apart from each other: In rectangles or strata that are to be sampled more than once by the same vessel it is recommended that valid hauls are separated by at least one day or by at least 10 miles wherever this is possible. Tows in adjacent rectangles should also be separated by at least 10 miles. DATRAS holds all the station data for historical surveys and could be used to help identify clear tows. Extra care should be taken if fishing using this information taken from the DATRAS database as some comments on obstructions at start and end of tows may not be available in the system.

Fish shoals located by sonar or echosounder should not influence fishing locations.



Construction of the 36/47 GOV trawl (adapted from drawings of the Institute des Peches Maritimes, Boulogne/Mer)

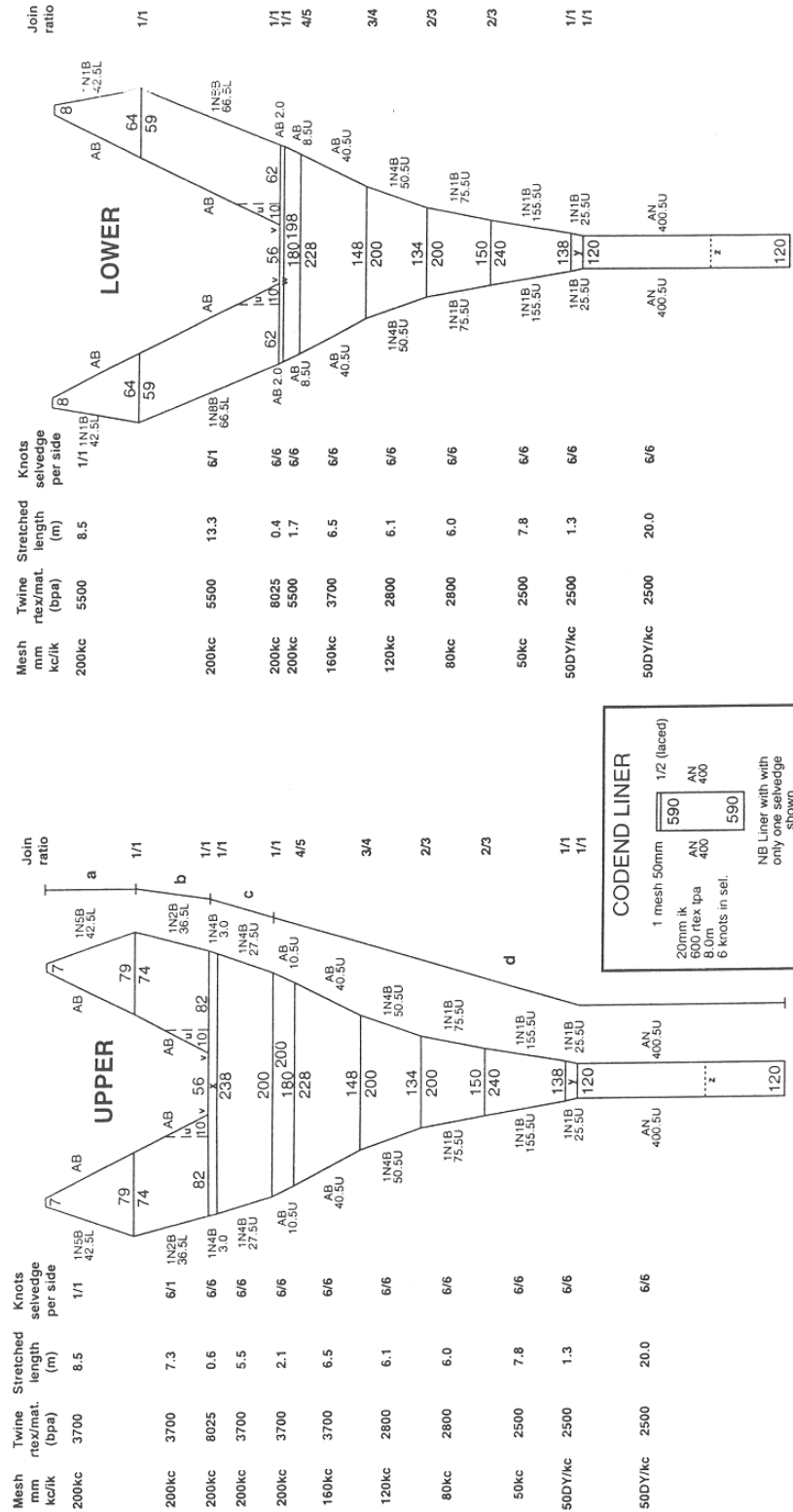

**Headline** : 36m (15.50 + 5.00 + 15.50) x 14mm  $\phi$  wire (f/c) served (6/19 - 12/6/1 65.8kg/100m).  
**Fishingline** : 47.20m (21.10 + 5.00 + 21.10) x 22mm  $\phi$  combination wire 6 strand/steel core 54.6kg/100m).  
**Winglines** : Upper 8.2m, Lower 8.2m x 20mm  $\phi$  combination wire (6 strand/steel core 54.6kg/100m)

a - 7.1m x 14mm  $\phi$  wire (6/19 - 12/6/1 - 65.8kg/100m)  
 b - 6.7m x 20mm  $\phi$  combination wire (6 strand/steel core - 54.4kg/100m)  
 c - 5.55m x 20mm  $\phi$  combination wire (6 strand/steel core - 54.4kg/100m)  
 d - length for length x 22mm  $\phi$  nylon (3 strand - 28kg/100m)

**NOTE TO NETMAKERS**  
 The numbers of meshes shown for netting panel widths do NOT include selvedge meshes. Five meshes (six knots) per selvedge must be added where indicated. Conversely to obtain panel depths one row (1/2 mesh) must be subtracted from each panel as the joining row is included in the number of meshes deep. The total numbers of meshes (width and depth) for each individual panel are set out in GOV 36/47 Groundfish Survey Trawl Checklist (Page 2 of 5)

**Legend:**  
 kc = knot centre to knot centre  
 ik = inside knot; measurement  
 tpa = polyamide twine/twisted  
 bpa = polyamide twine/brided  
 dy = double yarn  
 Method of join used; sewing.  
 Type of knot, weavers knot.

**Abbreviations:**  
 u - Gussets 6025rtex  
 v - 4 meshes gathered at quarters  
 w - 200 198  
 x - 240 238  
 y - 138 120  
 z - Joining position for Liner

Figure 2.5. Construction of the 36/47 GOV Trawl.

GOV 36/47 GROUND FISH SURVEY TRAWL : "Exocet" kite rigging

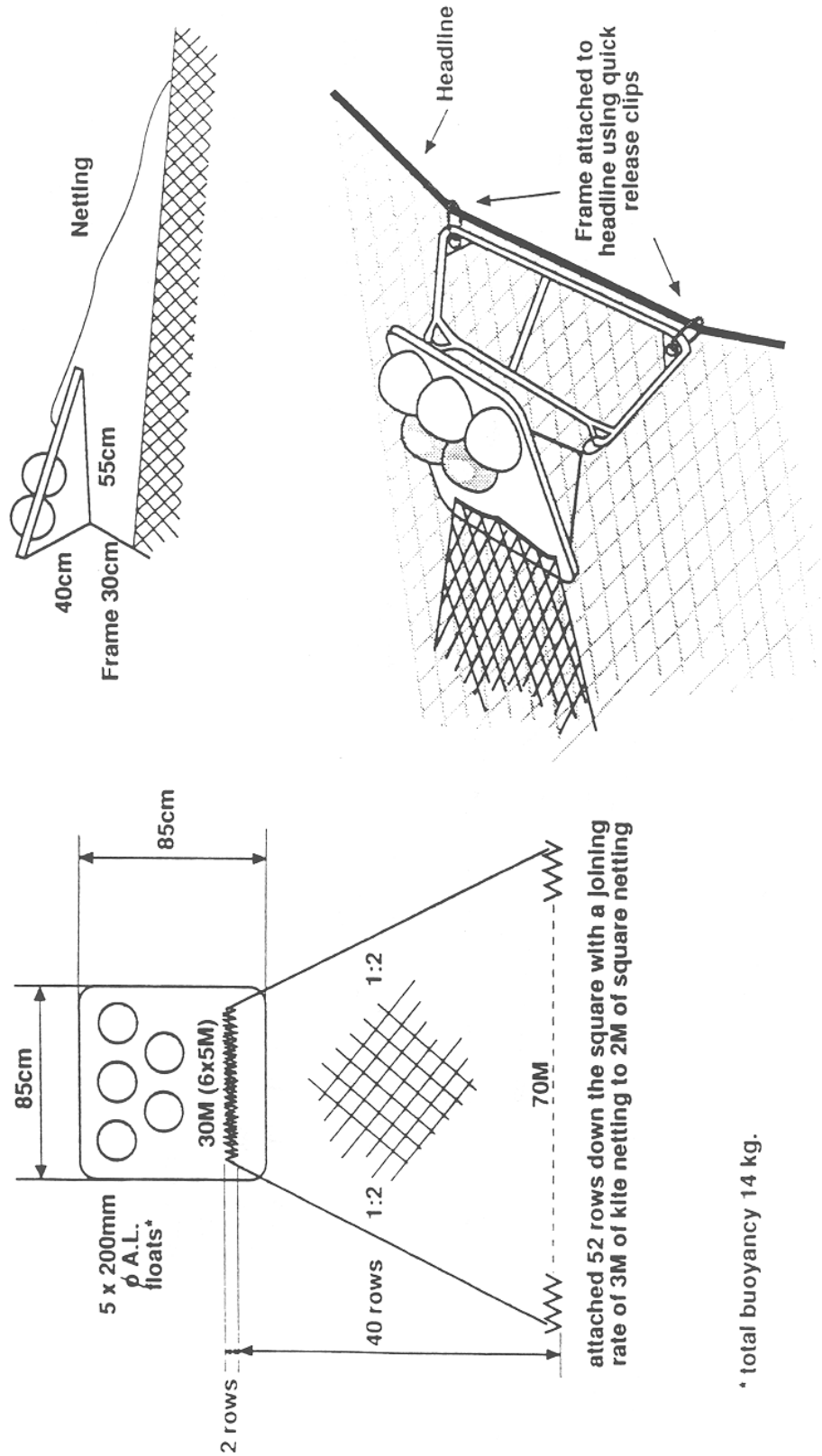

Figure 2.6. "Exocet" Kite for the 36/47 GOV Trawl.

GOV 36/47 GROUND FISH SURVEY TRAWL : Overall rigging diagram

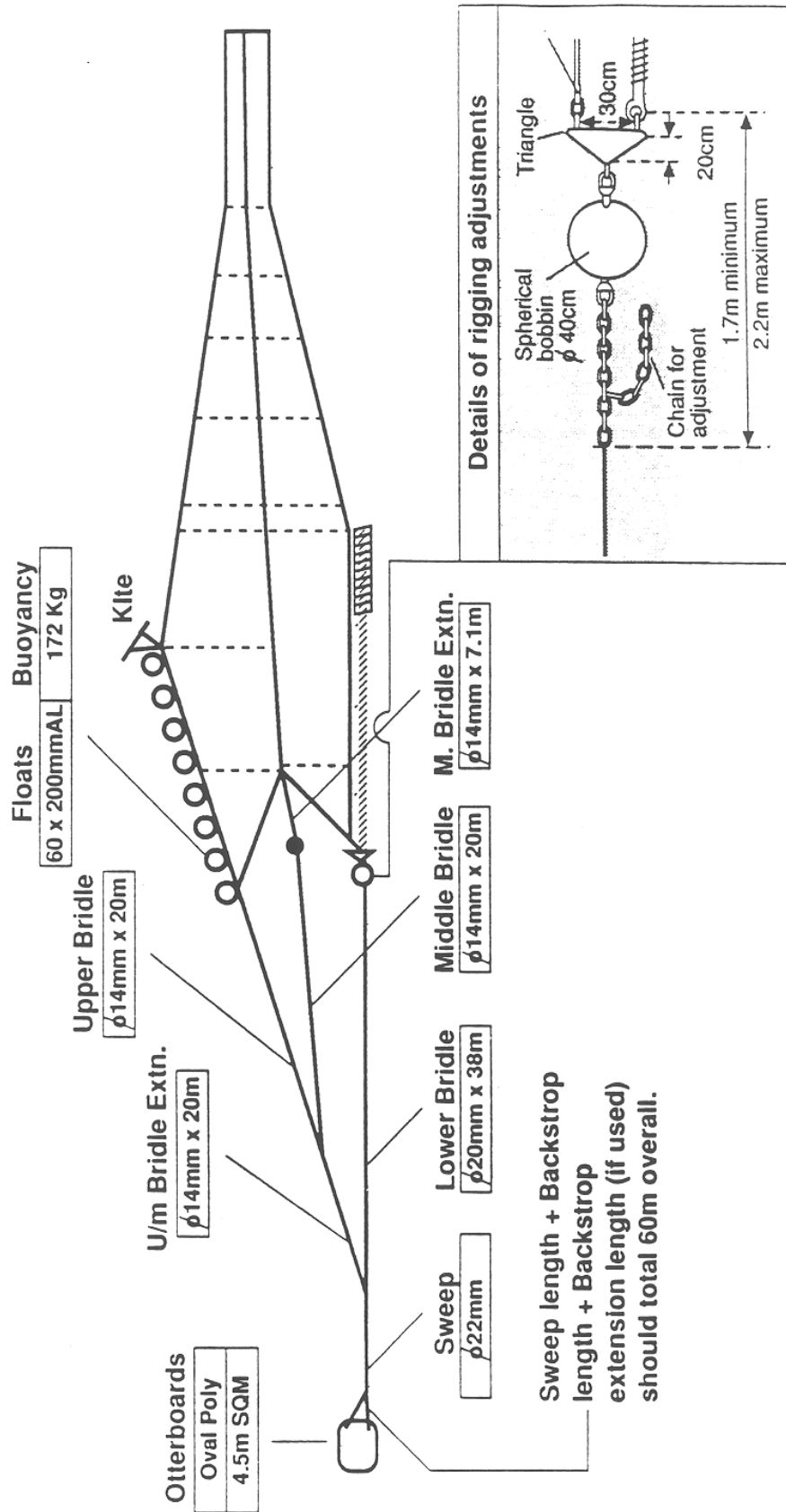

Figure 2.7. Rigging of the 36/47 GOV Trawl.

GOV 36/47 GROUND FISH SURVEY TRAWL : Ground gear rigging (Ground gear A)

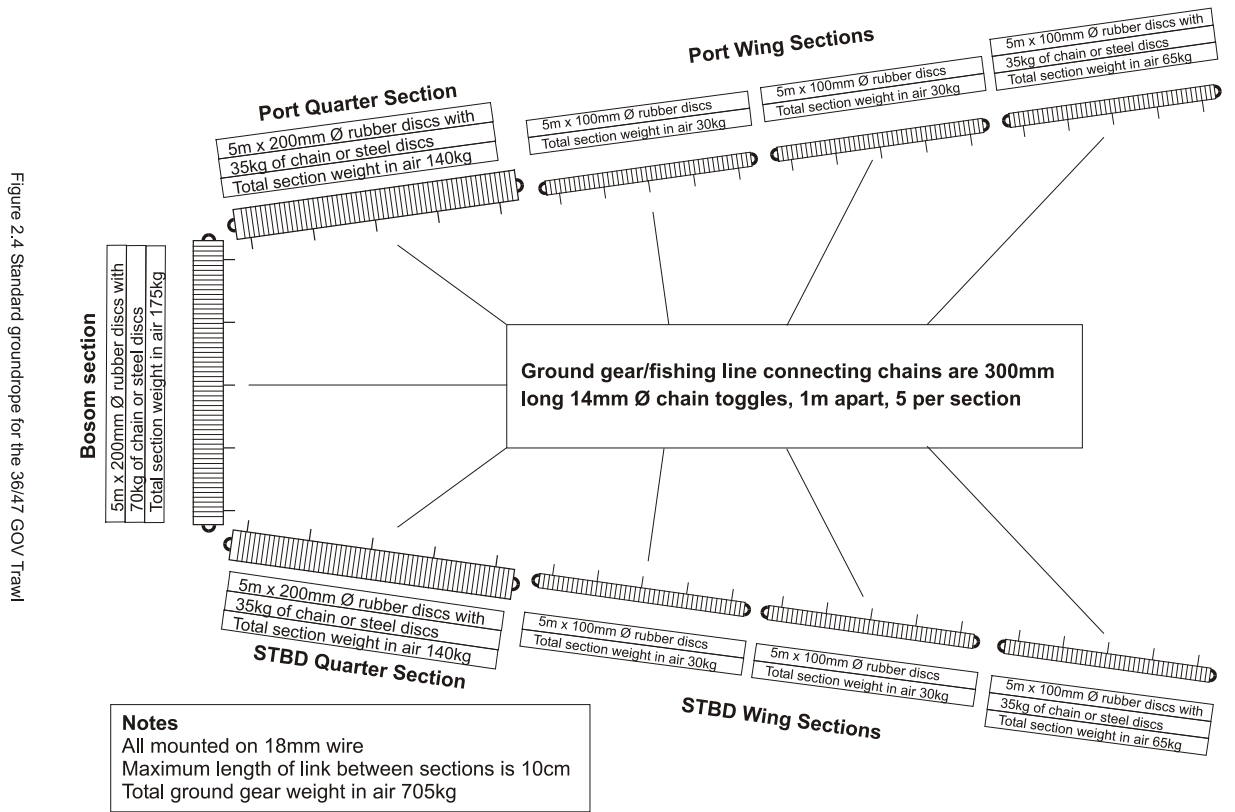
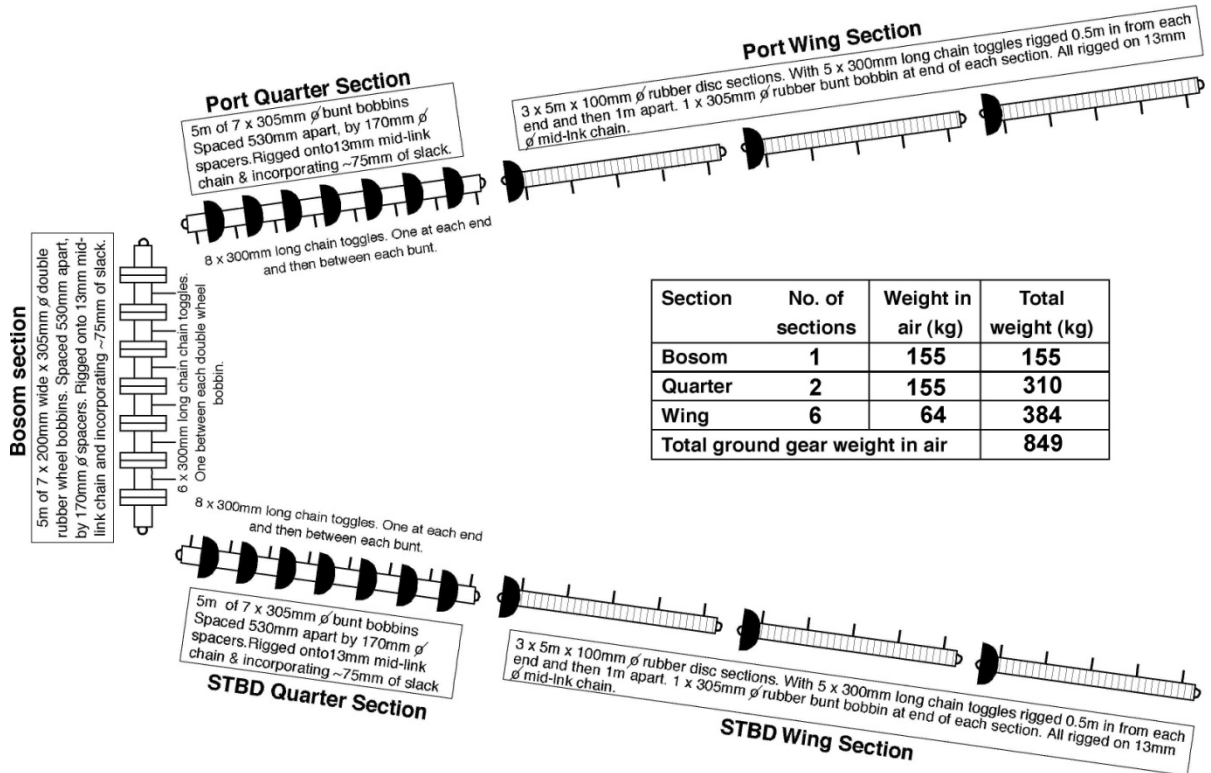

Figure 2.4 Standard groundrope for the 36/47 GOV Trawl

Figure 2.8. Standard groundrope for the 36/47 GOV trawl groundgear 'A'.

GOV 36/47 GROUND FISH SURVEY TRAWL : Ground gear rigging (Ground gear B)  
(Specification as from Jan 05 includes new toggles)



Notes : Each 5m long section includes the length of a hammerlock connector.

Figure 2.9. Standard groundrope for the 36/47 GOV trawl groundgear 'B'.

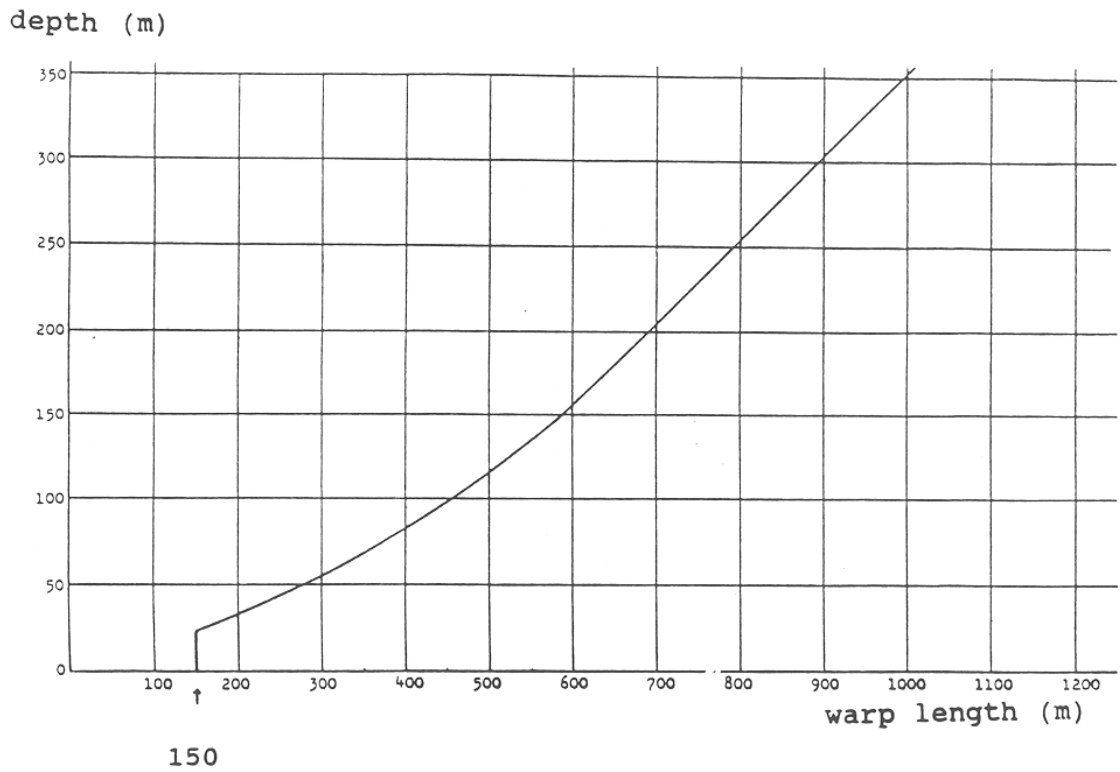

Figure 2.10. Warp out to depth ratio. To be used as a guide in consultation with Figures 2.11 and 2.12 to decide on correct gear parameters for towing the standard GOV.

For example, if fishing in 100 meters of water, the old recommendation was to deploy 450 meters of warp. With that amount of warp out the headline height and doorspread should be approximately 4.8m and 83m respectively. At this depth the warp out should be adjusted until these approximate figures are obtained. New plots will be produced once enough data has been collected.

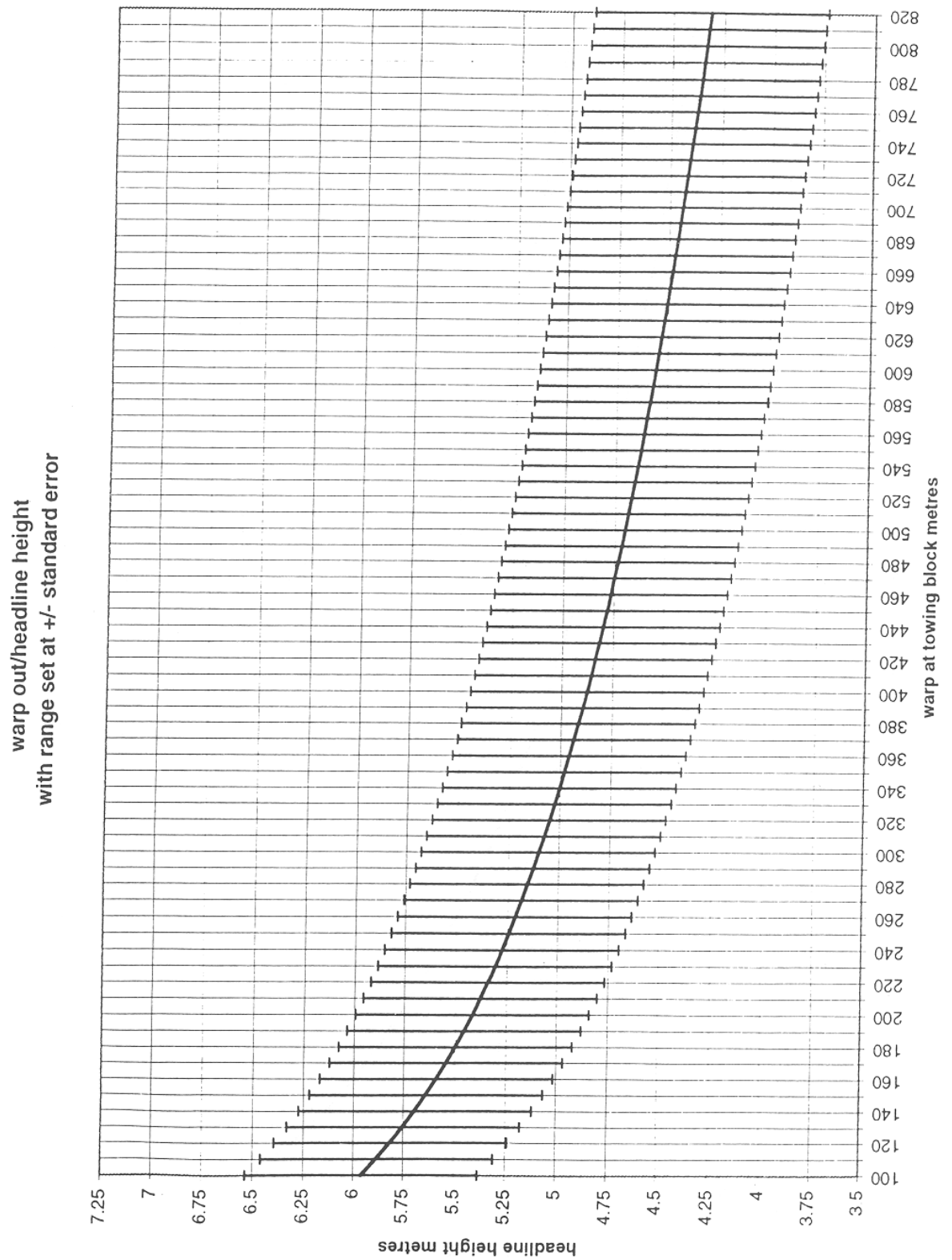

Figure 2.11. Expected warp out / headline height ratio.

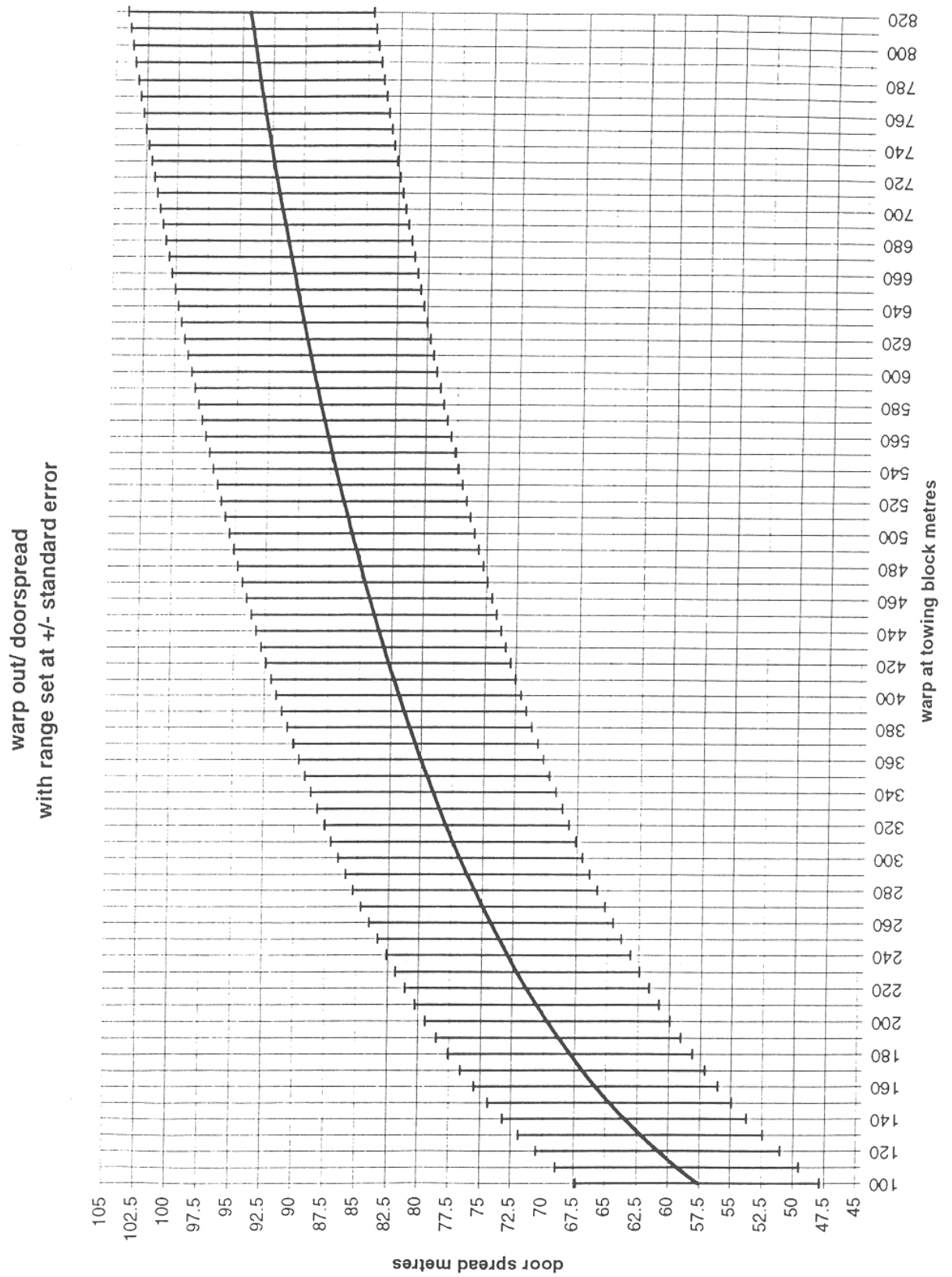

Figure 2.12. Expected warp out/door spread ratio.

### **3 Sampling of GOV-Trawl Catches**

---

#### **3.1 Catch sorting and sampling**

It is recommended that the catch from all valid hauls be sorted fully where practicable. Wherever possible, the entire catch is sorted, with fish and shellfish species identified to the lowest taxonomic level possible. For larger catches a selection of species/size categories of species may be identified as being sufficiently abundant that they can be subsampled, appropriately. If the entire catch cannot be sorted through then the data should be flagged accordingly when submitted to the DATRAS database. Appendices VI and VII show tables of catch processing procedures (from Report of the International Bottom Trawl Survey Working Group, ICES 2002).

Although standardized data collection for fish is well established in IBTS protocols, and these data are submitted to DATRAS, there is no standardized approach to the submission of data on the catches and size distribution of cephalopods and shellfish. Some national laboratories record other invertebrate species ("benthos"), though no agreed protocols for the collection and submission of data exist, as the levels of taxonomic expertise on board vessels can be variable. The GOV is not an effective gear for catching benthos for quantitative sampling it can be used for some crude distribution information, remembering the limitation of the gear, given the groundgear set up and the size of the meshes within the net make-up. This data can be collected as presence/absence or to more sophisticated means (weights/numbers). It is at the discretion of the institute collecting the data to decide what means is most appropriate. Hence, national laboratories collecting information on benthos should continue to do so, though such data should not be reported to DATRAS until rigorous quality assurance and reporting procedures are in place, so as to ensure that data are of high quality.



Table 3.1 Shellfish and cephalopods to be recorded during surveys.

TSN CODE	COMMON NAME	SCIENTIFIC NAME	RECORDING	MEASUREMENT	UNIT
<b>CRUSTACEANS</b>					
98682	Golden crab	<i>Cancer bellaninus</i>	Male/Female	Carapace width	mm below
98681	Edible crab	<i>Cancer pagurus</i>	Male/Female	Carapace width	mm below
98908	Deep-water red crab	<i>Geryon affinis</i>	Male/Female	Carapace width	mm below
97315	European lobster	<i>Homarus gammarus</i>	Male/Female	Carapace length	mm below
97657	Crawfish/spiny lobster	<i>Palinurus elephas</i>	Male/Female	Carapace length	mm below
552966	Pink spiny lobster	<i>Palinurus mauritanicus</i>	Male/Female	Carapace length	mm below
199961	Spider crab	<i>Maja (Maia) squinado</i>	Male/Female	Carapace length	mm below
97317	Norway lobster	<i>Nephrops norvegicus</i>	Male/Female	Carapace length	mm below
97943	Stone crab	<i>Lithodes maja</i>	Male/Female	Carapace length	mm below
<b>BIVALVES</b>					
79683	Edible scallop	<i>Pecten maximus</i>	Sexes combined	-	-
79716	Queen scallops	<i>Aequipecten opercularis</i>	Sexes combined	-	-
79885	Common oyster	<i>Ostrea edulis</i>	Sexes combined	-	-
<b>CEPHALOPODS</b>					
82363	Cuttlefish	<i>Sepia officinalis</i>	Sexes combined	Mantle length	cm below
82362	Cuttlefish	<i>Sepia elegans</i>	Sexes combined	Mantle length	cm below
82364	Cuttlefish	<i>Sepia orbignyana</i>	Sexes combined	Mantle length	cm below
-	Squids	<i>Teuthoidea*</i>	Sexes combined	Mantle length	cm below
82646	Lesser octopus	<i>Eledone cirrhosa</i>	Sexes combined	-	-
82603	Octopus	<i>Octopus vulgaris</i>	Sexes combined	-	-
-	Bobtail squids etc. *	<i>Sepioida/Rossia/Sepietta</i>	Sexes combined	-	-

\* to species level where possible, though juveniles may need to be aggregated

The following flow diagram (Figure 3.1) can be used as a guide to dealing with the catch.

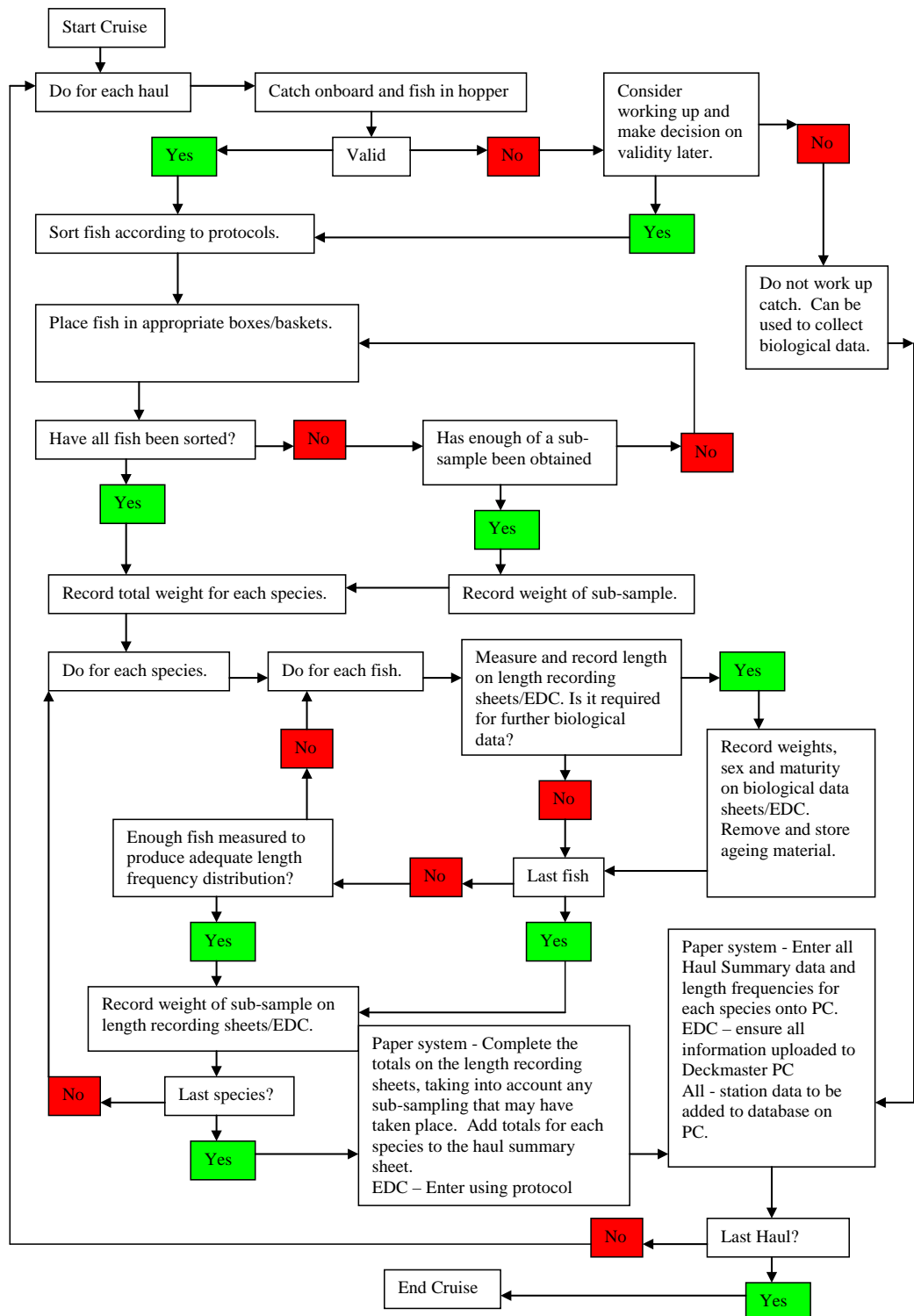

Figure 3.1. IBTS catch processing flow diagram.

### 3.2 Length composition

Length distributions are recorded for **all fish species caught**. Length is defined as total length, measured from tip of snout to tip of caudal fin, for all fish species other than those described in Section 3.4. Length is measured to 0.1cm below for shellfish, to 0.5 cm below for herring and sprat, and to 1 cm below for all other species. When measuring shellfish species, Figures 3.2 to 3.5 should be consulted to ensure the correct carapace measurement is taken. When measuring cephalopods the mantle length should be used, Figure 3.6.

It is recommended that elasmobranchs and shellfish should be measured and weighed by sex.

After sorting the catch into species or species/sex, we need to obtain a length distribution for each catch category that accurately represents the length distribution. Where the numbers of individuals are too large for them all to be measured, a representative subsample is selected of at least 75 fish, although sampling a very limited length range could be adequately achieved with less. A proper representation of the given length distribution is key.

In the event that a truly representative subsample cannot be selected, it will be necessary to further sort the species into two or more size grades or categories. The following two examples are used to describe incidences when grading or categorization may be required but are by no means exhaustive.

Example 1 - A catch element consists of 999 fish in the length range 18 - 26cm and one fish at 40cm. It is evident that a single subsample of 100 fish when raised up will give either 10 or zero fish at 40cm. The correct approach is to remove the one large fish and measure it separately, treating that sample as category 1, and take a subsample from the remaining 999 fish (category 2). When measured and raised this provides an accurate assessment of the numbers caught at each length for this element of the catch.

Example 2 - A catch element consists of 994 fish in the length range 18-26cm and 3 fish in the length range 10-12cm and 3 fish in the length range 38-40cm. It is evident that a single raised subsample of 100 fish could give anything between zero and 10 fish in the length ranges 10-12cm and 38-40cm. The correct approach is to remove the small and large fish and measure them as category 1, then take a subsample from the remaining 994 fish (category 2). When measured and raised this provides an accurate assessment of the numbers caught in each length group for this element of the catch

In case of large catches ( $n > 1000$ ) of any species, it is recommended that the minimum sample size given above should be doubled. This will help to ensure that any extremes of the length range are covered.

Fish should be identified to the species level. Only if this proves impossible may some be grouped by genus or larger taxonomic group (e.g. *Pomatoschistus*, *Ammodytidae*).

### 3.3 Sampling for Age, Sex and Maturity

Otolith samples are to be collected within 10 specified sampling areas as illustrated in Figure 6.2. For all species the same areas are used but care should be taken not to extract otoliths from fish that exhibit length deformities.

For the target species the following minimum sampling levels should be maintained for each sampling area:

SPECIES	MINIMUM NUMBER OF OTOLITHS TO BE TAKEN PER ROUND FISH AREA
herring :	8 otoliths per 1/2 cm group
sprat :	16 otoliths per 1/2 cm group 8.0-11.0cm
	12 otoliths per 1/2 cm group >11.0cm
mackerel :	8 otoliths per 1 cm group
cod :	8 otoliths per 1 cm group
haddock :	8 otoliths per 1 cm group
whiting :	8 otoliths per 1 cm group
Norway pout :	8 otoliths per 1 cm group
saithe :	8 otoliths per 1 cm group

For the smallest size groups, that presumably contain only one age group, the number of otoliths per length class may be reduced. Conversely, more otoliths per length group are required for the larger length classes.

Participants are encouraged to collect age samples also from other commercially important species such as plaice, IIIa sole lemon sole and any other species deemed important to the EU Data Collection Framework (DCF), or specified by the IBTS working group.

**Sex, maturity and weight** data should be reported for all the target species for which age data are collected. Maturity stages should be reported according to the maturity scales given in Appendix VIII and IX. When institutes are assigning biological targets for their surveys consideration should be taken to ensure that data are collected from the entire survey area.

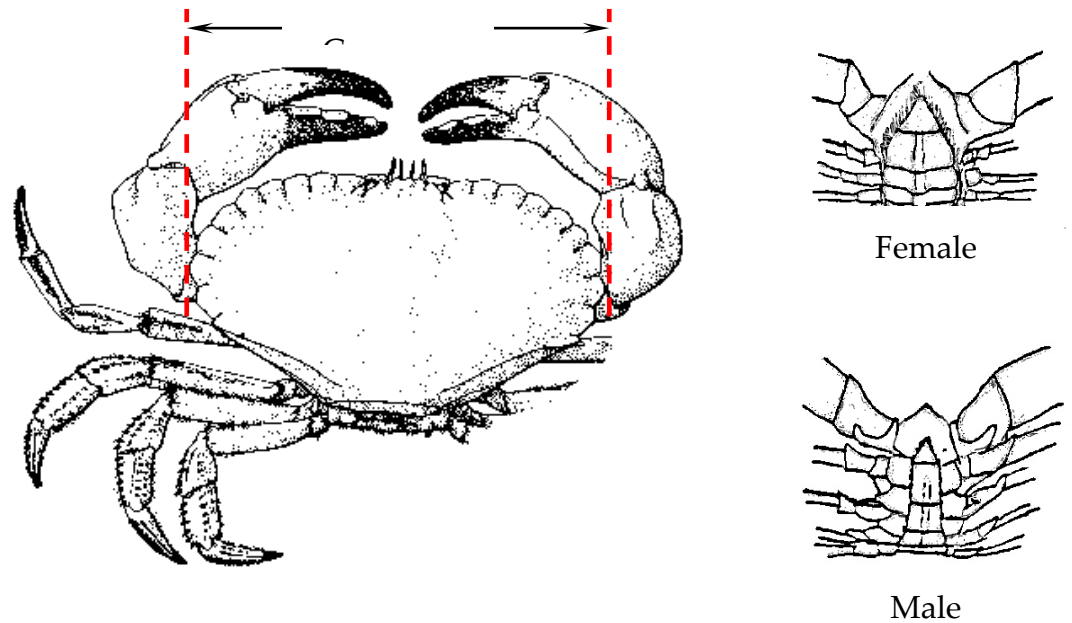

Figure 3.2. Measurement and sexing of *Cancer pagurus*. Size to be measured to the lower mm.

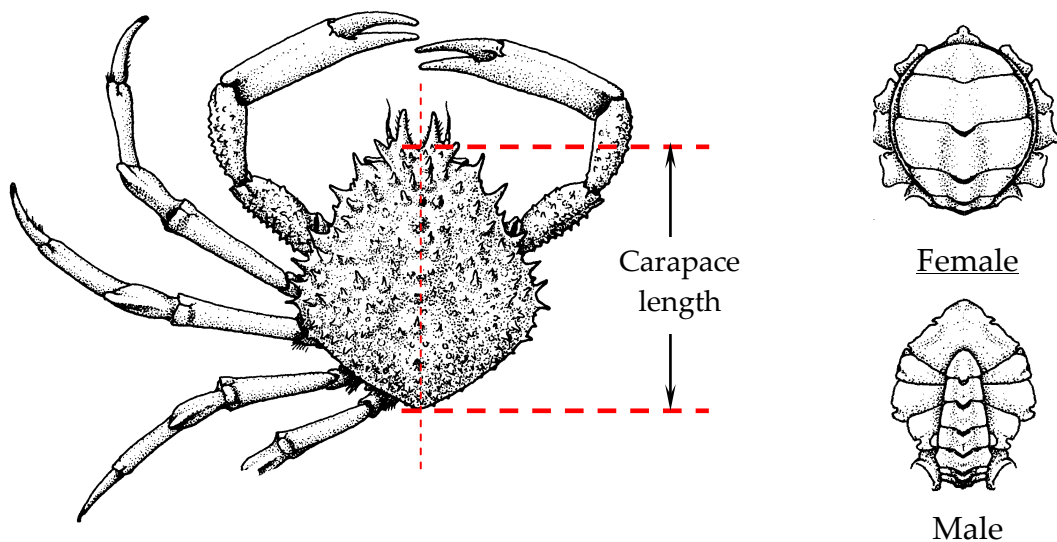

Figure 3.3. Measurement and sexing of *Maia squinado*. Size to be measured to the lower mm. *Lithodes maja* measured across same carapace position.

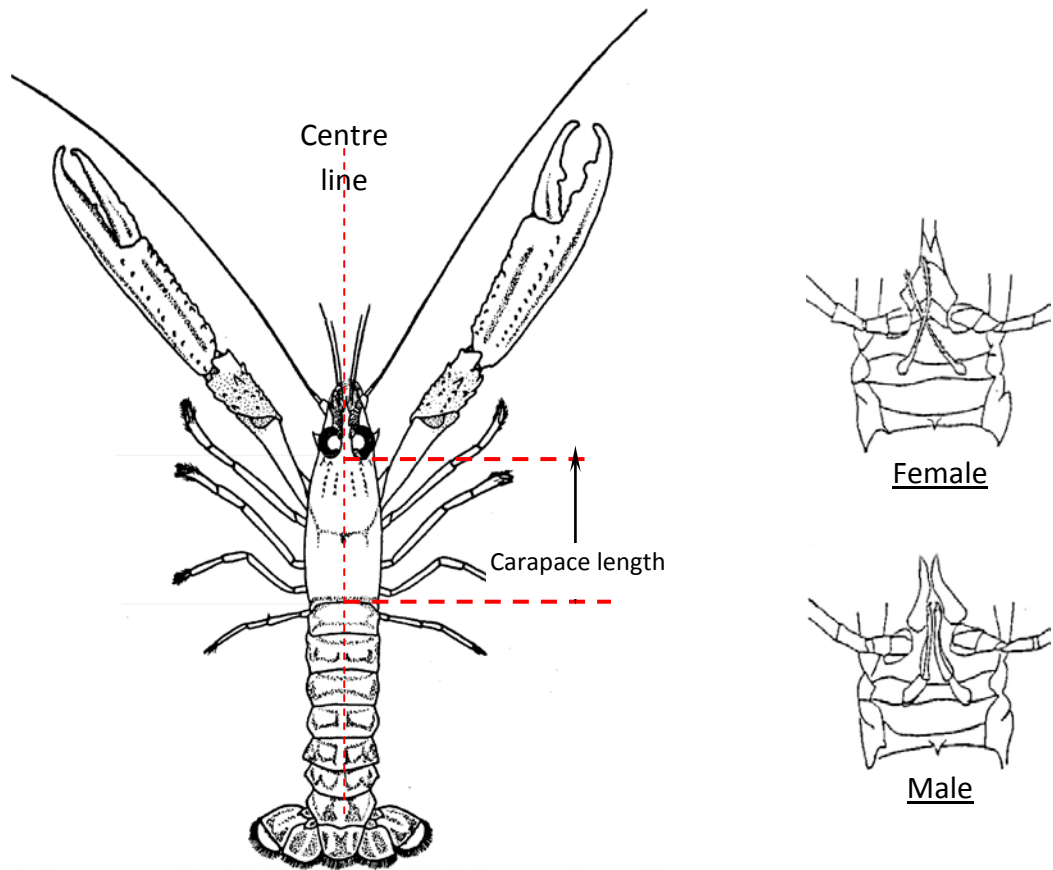

Figure 3.4. Measurement and sexing of *Nephrops norvegicus* and *Homarus gammarus* Size to be measured to the lower mm.

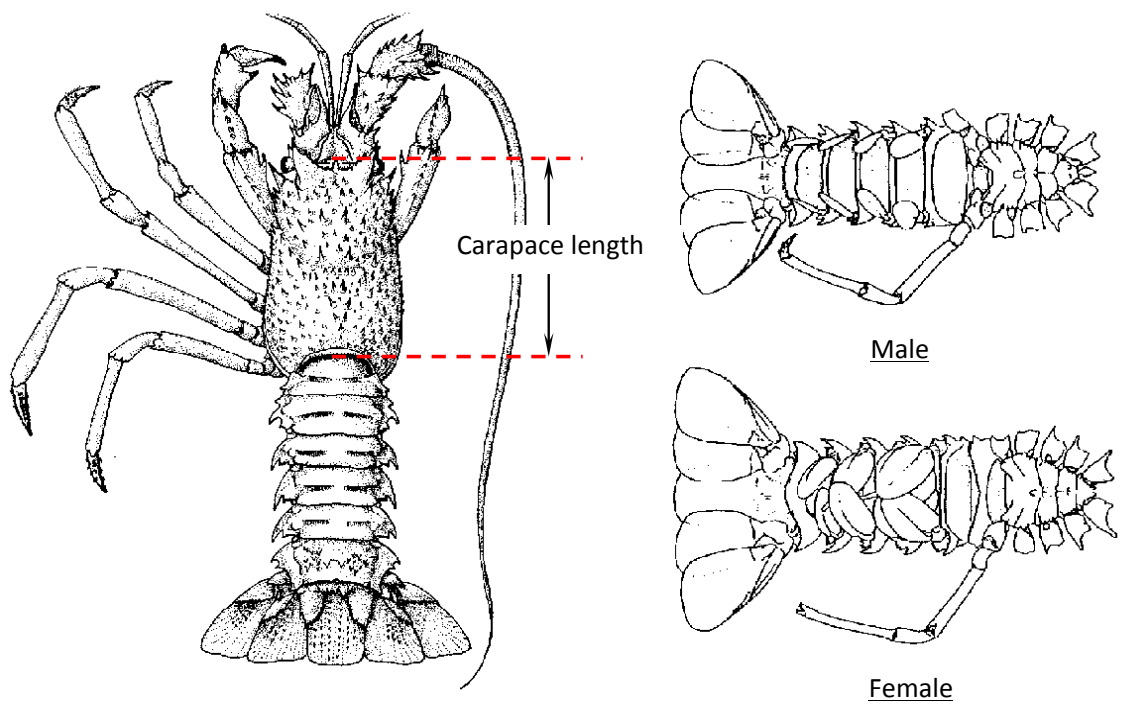

Figure 3.5. Measurement and sexing of *Palinurus* spp Size to be measured to the lower mm.

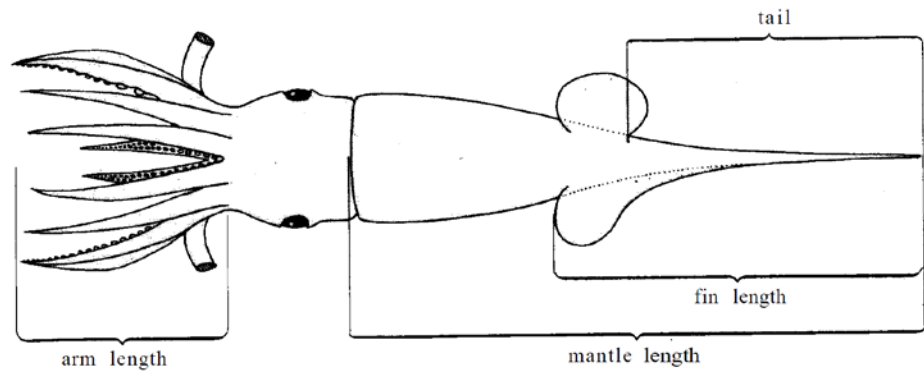
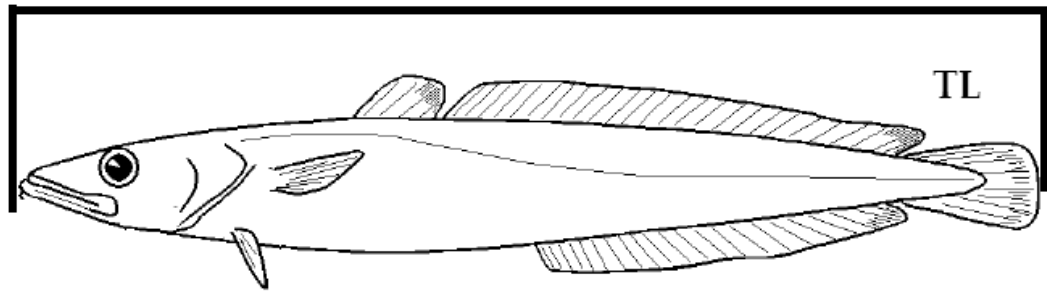

Figure 3.6. Measurement of Cephalopods. Mantle length to be measured to lower mm.

### 3.4 Measurement types for deep-water species



The majority of species encountered during the deep-water surveys are measured to the centimetre below using total length as the length qualifier (**TL**; see diagram directly above). There are however some exceptions. Due to the great variety of body shapes of deep-water fish species and the fragility of their tails and fins some species are not measured to total length. Listed below are the respective taxa with details of the length measurements to be collected for each.

#### 3.4.1 Smoothheads and Searsids (*Alepocephalidae* and *Searsidae*)

**SL** - Standard length measurement taken from the tip of snout/anterior point of head to the end of the fleshy caudal peduncle. Not to be confused with **TL** which includes the caudal fin rays. All smoothheads and searsids are measured to the nearest whole cm below.

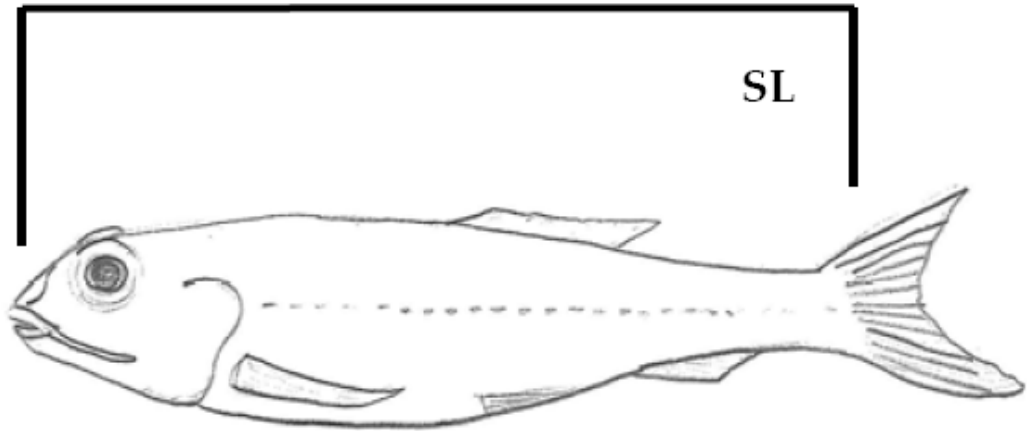

**3.4.2 Grenadiers (*Macrouridae*)- PAFL – Pre Anal Fin Length**

Measurement taken from the tip of the snout to the first anal fin ray. (See diagram below). All grenadiers are measured to the nearest 0.5cm below.

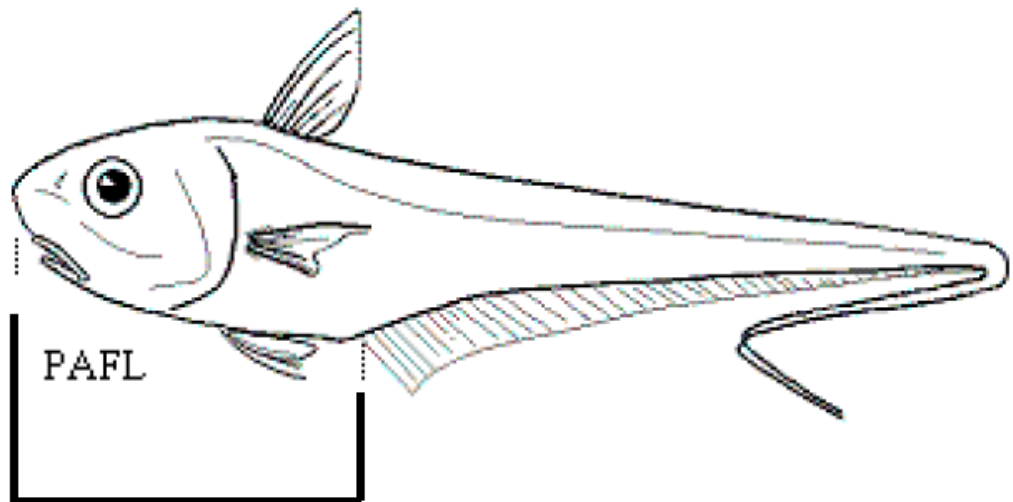



### 3.4.3 Chimaeridae (Rabbitfish) – PSCFL – Pre Supra Caudal Fin Length

Applies to all **Rabbitfish** except Rhinochimaeridae. (See diagram below). Measured from the tip of the snout to the point just before the start of the supra caudal fin.

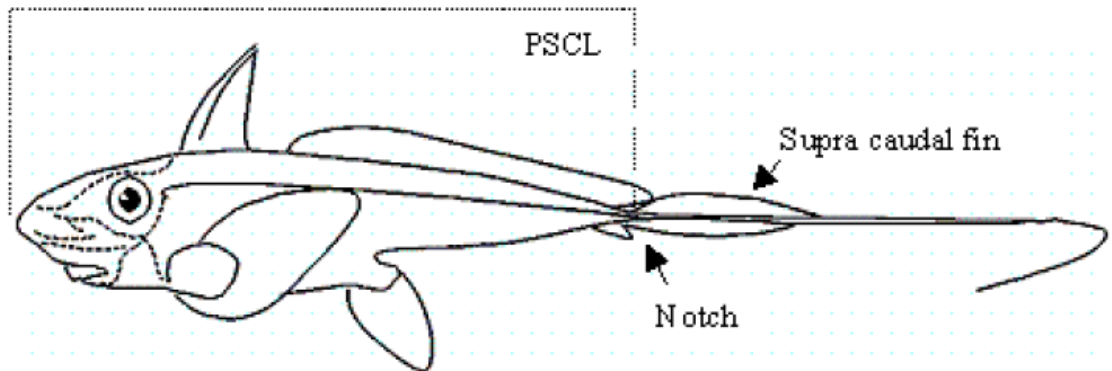

## 4 Methot Isaac Kidd Net

### 4.1 Construction and Rigging

The Methot Isaac Kidd (MIK) net is a midwater ring trawl and is the standard gear for the sampling of fish larvae during the International Bottom Trawl Survey in the first quarter.

The parts of the gear, as shown in Figures 4.1 and 4.2 are:

- a) Ring of 2 meter diameter
- b) Black net of 1.6 mm pore, 13 meter long, strengthened by nylon straps. In the last meter of the net a 500 mm net is inserted (b1)
- c) Bolts for mounting the net on the ring
- d) Saddle shaped weight of 25kg approx; weight dependent on weight of the 2m ring.
- e) Pair of 10 meter long bridles to the gear
- f) Pair of 3.0 meter long bridles to the weight
- g) Bucket (Ø 11 cm) for collection of the plankton sample
- h) Flow meter mounted on a string crossing the ring, positioned in the centre of the ring

### 4.2 Fishing Method

Because of the length of the bridles it is necessary to haul them through the block; thus a strong block is necessary, and the connection between bridle and hauling wire ought to be relatively small.

In order to monitor the distance of the gear to the bottom an echosounder should be mounted, optionally wireless echo and/or depth sounder (e.g. SCANMAR) should be used. This should be placed in the lower part of the ring.

If no wireless sounder is available the transmitting cable could be relieved by use of a second, 9-10 meter long, pair of bridles as shown in Figure 4.3.

When the gear is put out the net should float freely, and the weight should be underwater before the ring is lowered underwater.

The following procedures should be used at all times and no deviation from these should be allowed.

- 1) Hauls should only be made during the period between 30 minutes past sunset to 30 minutes before sunrise (see table in Section 2.3 for the definition of sunrise and sunset). If there is no cloud cover, i.e. the daylight period has been extended, then fishing should not begin until 60 minutes after sunset and cease 60 minutes before sunrise.
- 2) Fishing speed is 3 knots through the water.
- 3) The haul profile is oblique to 5 meter above the bottom (i.e. measured from the lower part of the ring). Maximum depth of tow should, however, be 100 meter. If the haul duration of a single oblique haul is less than 10 minutes a double oblique haul must be made.
- 4) The wire is paid out at a speed of 25 meter per minute and retrieved at 15 m/min.
- 5) The flowmeter is read before and after each haul.
- 6) The duration and distance towed must be recorded.
- 7) All hauls should be a minimum of 10nm apart.
- 8) The position of sampling is the shooting position.
- 9) On deck the hindmost part of the net (the 500 mm netting) is washed into the bucket.

Once these procedures have been completed the next section is to be followed.

### 4.3 Sample and Data Treatment

The samples should be preserved in either 4% formalin in freshwater or in 96% ethanol. Type of preservation should be indicated on the standard form (Figure 4.4).

It is recommended that lengths of larvae are measured after preservation. If measurements are made before preservation this should be indicated on the standard form (Figure 4.4).

Herring and sprat larvae should be identified, and their standard length (see Figure 4.5) measured to the millimetre below. If larvae are preserved in ethanol, approximately 30 minutes in freshwater will soften them, making measuring easier.

Catches of eel and volume of krill should also be indicated on the standard form. Optionally other species may be reported.

Preferably samples are processed and reported within one month after termination of the survey. The immediate reporting of herring and sprat catches (for the use of the Herring Assessment Working Group Meeting) should be made using the standard spreadsheet e-mailed to Peter Munk ([pm@dfu.min.dk](mailto:pm@dfu.min.dk)). Subsequently the standard forms (Figure 4.4) should be mailed to Peter Munk, Danish Institute for Fisheries DIFRES, Charlottenlund Castle, DK-2920 Charlottenlund, Denmark.

The data will be included in a database at DIFRES. A revised copy of the data will be available at the ICES Secretariat.

The standard area for which the abundance of herring larvae is calculated is shown in Figure 6.5. Figure 6.6 shows a plot of the North Sea with the weightings given to all rectangles for calculation of the larval index in quarter 1.

#### 4.4 Calibration of the Flowmeter

The flowmeter used in the survey should be calibrated to revolutions per meter. One method is to tow the MIK (without the bucket) at a depth of about 10 meter for a known distance and make at least two measurements in opposite directions.

#### 4.5 Allocation of Rectangles

At least 2 hauls per ship per rectangle are made within each standard rectangle and the distance between hauls within and between rectangles is at least 10 nm. In the Southern Bight abundance of herring larvae is very variable. Intensified sampling should therefore be carried out in this area.

If possible, more than 2 hauls per ship per rectangle should be made in the following rectangles: 30F1, 32F2, 32F3, 33F2, and 33F3.

Each year, the first quarter coordinator announces the allocation of rectangles to all participants.

During the survey the status of MIK-sampling should be reported to the coordinating vessel. If there is any risk that rectangles will be left unsampled then initiatives should be taken to reallocate sampling between participants.

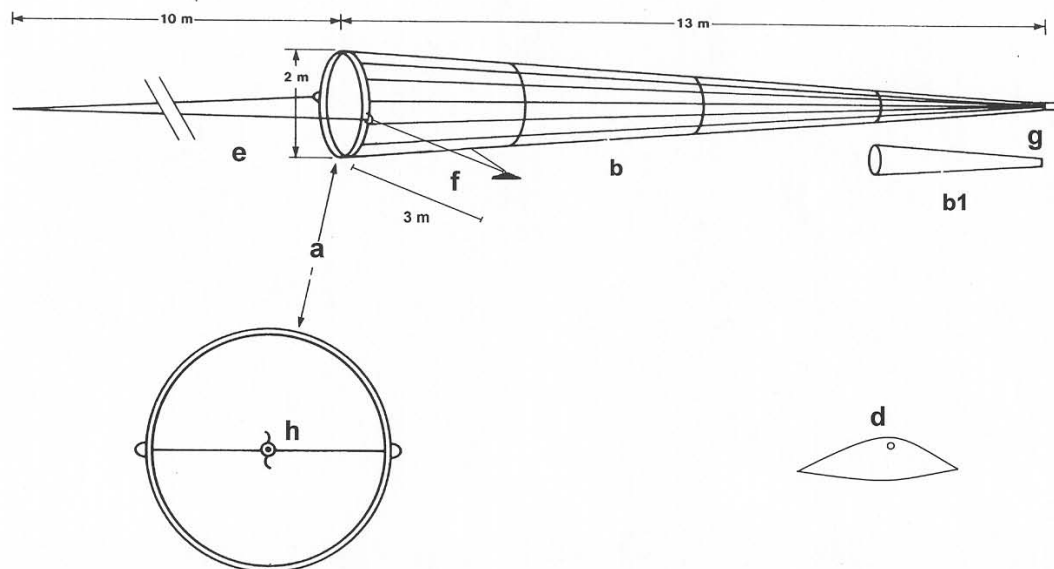

Figure 4.1. Construction and rigging of the MIK trawl. Letters refer to description in the text.

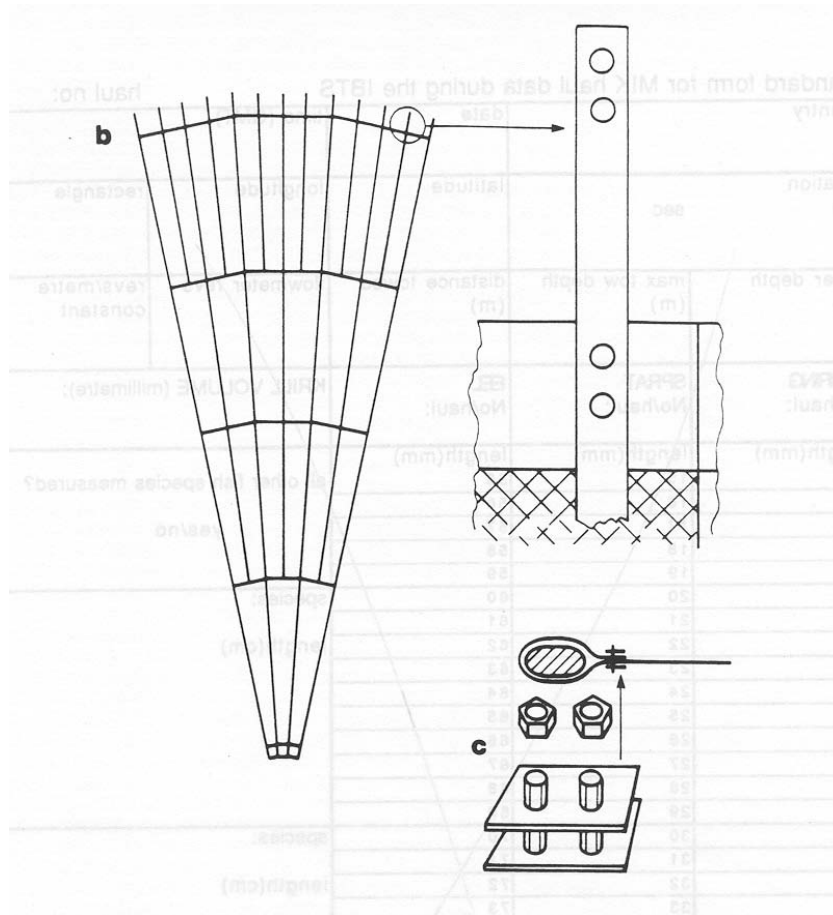

Figure 4.2. Unfolded net of the MIK midwater trawl and illustration of net attachment.

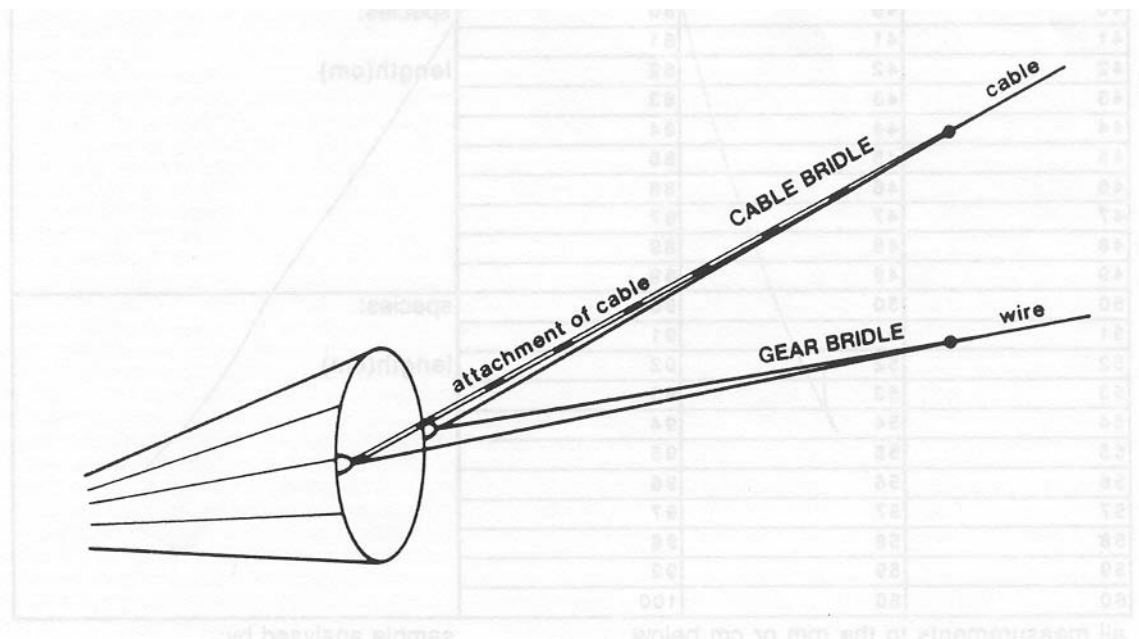

Figure 4.3. Proposed rigging of transmitting cable.

Standard form for MIK haul data during the IBTS

haul no:

country		date	time (GMT)	
duration min	sec	latitude	longitude	rectangle
water depth (m)	max tow depth (m)	distance towed (m)	flowmeter revs	revs/metre constant
HERRING No/haul:	SPRAT No/haul:	EEL No/haul:	KRILL VOLUME (millilitre)	
length (mm) 15	length (mm) 25	length (mm) 55	measured to millimetre below: yes / no	
16	26	56		
17	27	57		
18	28	58	preserved in ethanol:           yes / no	
19	29	59		
20	30	60		
21	31	61	species: length (cm)	
22	32	62		
23	33	63		
24	34	64		
25	35	65		
26	36	66		
27	37	67		
28	38	68		
29	39	69		
30	40	70		
31	41	71	species: length (cm)	
32	42	72		
33	43	73		
34	44	74		
35	45	75		
36	46	76		
37	47	77		
38	48	78		
39	49	79		
40	50	80		
41	51	81	species: length (cm)	
42	52	82		
43	53	83		
44	54	84		
45	55	85		
46	56	86		
47	57	87		
48	58	88		
49	59	89		
50	60	90		
51	61	91	species: length (cm)	
52	62	92		
53	63	93		
54	64	94		
55	65	95		
56	66	96		
57	67	97		
58	68	98		
59	69	99		
60	70	100		

all measurements to the mm or cm below  
see IBTS Manual for guidelines

sample analysed by:

Figure 4.4. Standard form for MIK haul data.

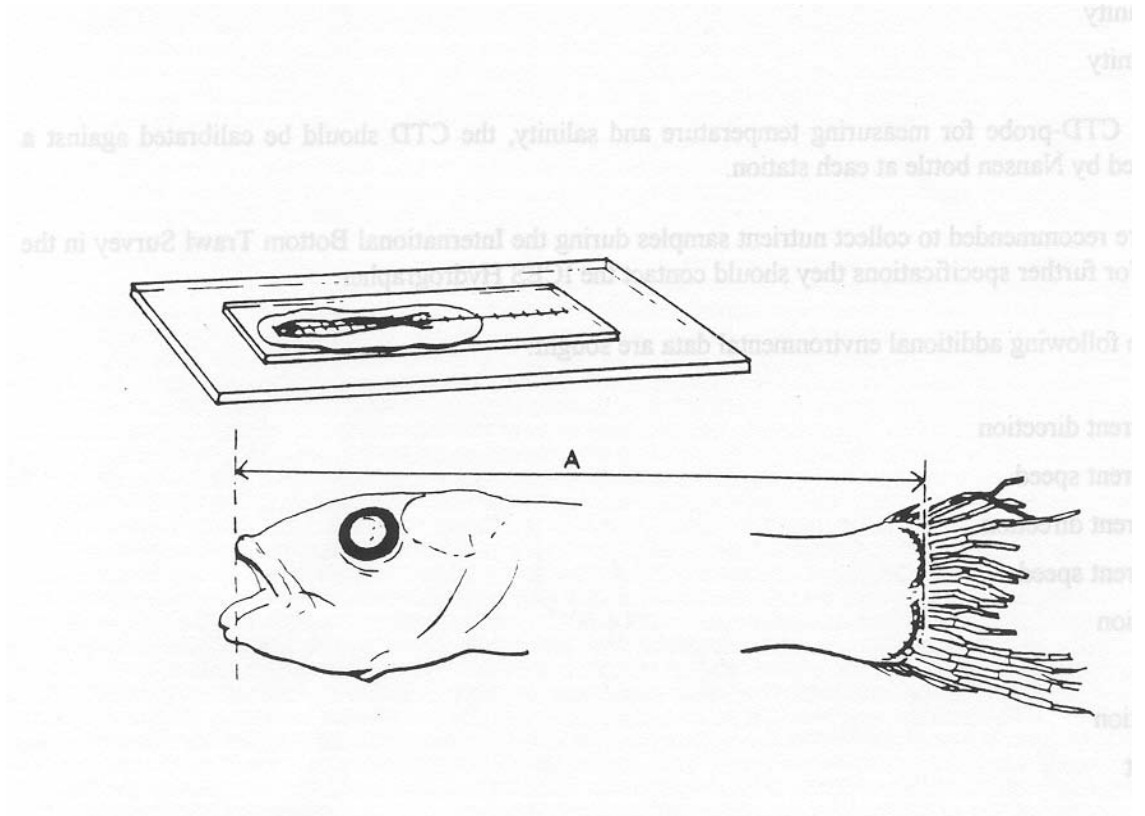

Figure 4.5. Measurement of standard length of herring and sprat larvae (to the millimetre below).

## 5 Environmental data

---

Either before or after each haul with the GOV trawl, the following minimum hydrographical data are collected:

- surface temperature
- bottom temperature
- surface salinity
- bottom salinity

When using a CTD-probe for measuring temperature and salinity, an appropriate calibration should be undertaken.

Participants are recommended to collect nutrient samples during the International Bottom Trawl Survey in the first quarter. For further specifications they should contact the ICES Data Centre.

Since 1992 the following additional environmental data are sought:

- surface current direction
- surface current speed
- bottom current direction
- bottom current speed
- wind direction
- windspeed
- swell direction
- swell height

The above parameters should be reported in the 'Haul Information file HH' (Appendix IX).

## 6 Exchange specifications for IBTS data

---

Three distinct types of computer records have been defined for standard storage of the IBTS data:

Type 1: HH - Record with detailed haul information (Appendix X)

Type 2: HL -Length frequency data (Appendix XI)

Type 3: CA - Sex-maturity-age-length keys (SMALK; Appendix XII)

The summaries of the formats of these record types are given in the appendices given above, and detailed descriptions can also be found at the ICES web page: <http://www.ices.dk/datacentre/datsu/selrep.asp>.

Provisional data obtained from the North Sea and Skagerrak/Kattegat should be submitted to the quarterly coordinator as soon as possible after completion of the cruise. Appendix XIII lists the sampling areas and standard areas for the calculation of abundance indices (using Figures 6.1 to 6.5 for guidance) and appendix XIV lists the length splits for the various target species. Final data should only be submitted to the ICES Data Centre after the national institute has checked the data using official checking programs issued by ICES.

**NB:**

Details of environmental data should be submitted to the ICES Data Centre according to established procedures. The national hydrographic station number must be reported in Record Type 1 to enable the link to be made between haul data and environmental data.

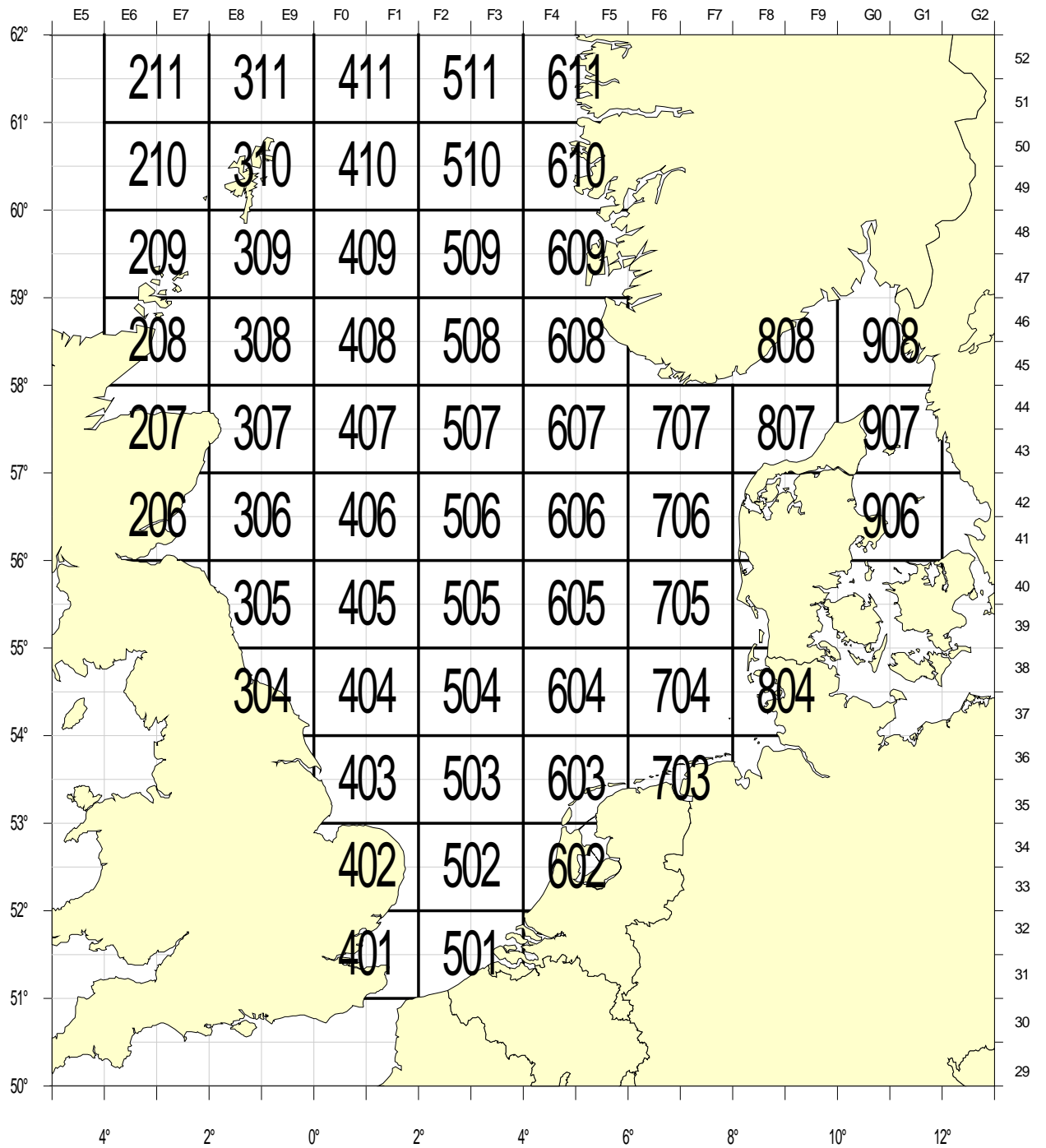

**Figure 6.1. Four Statistical Rectangles: used for sampling roundfish otoliths up to and including 1979, for herring up to and including 1982.**



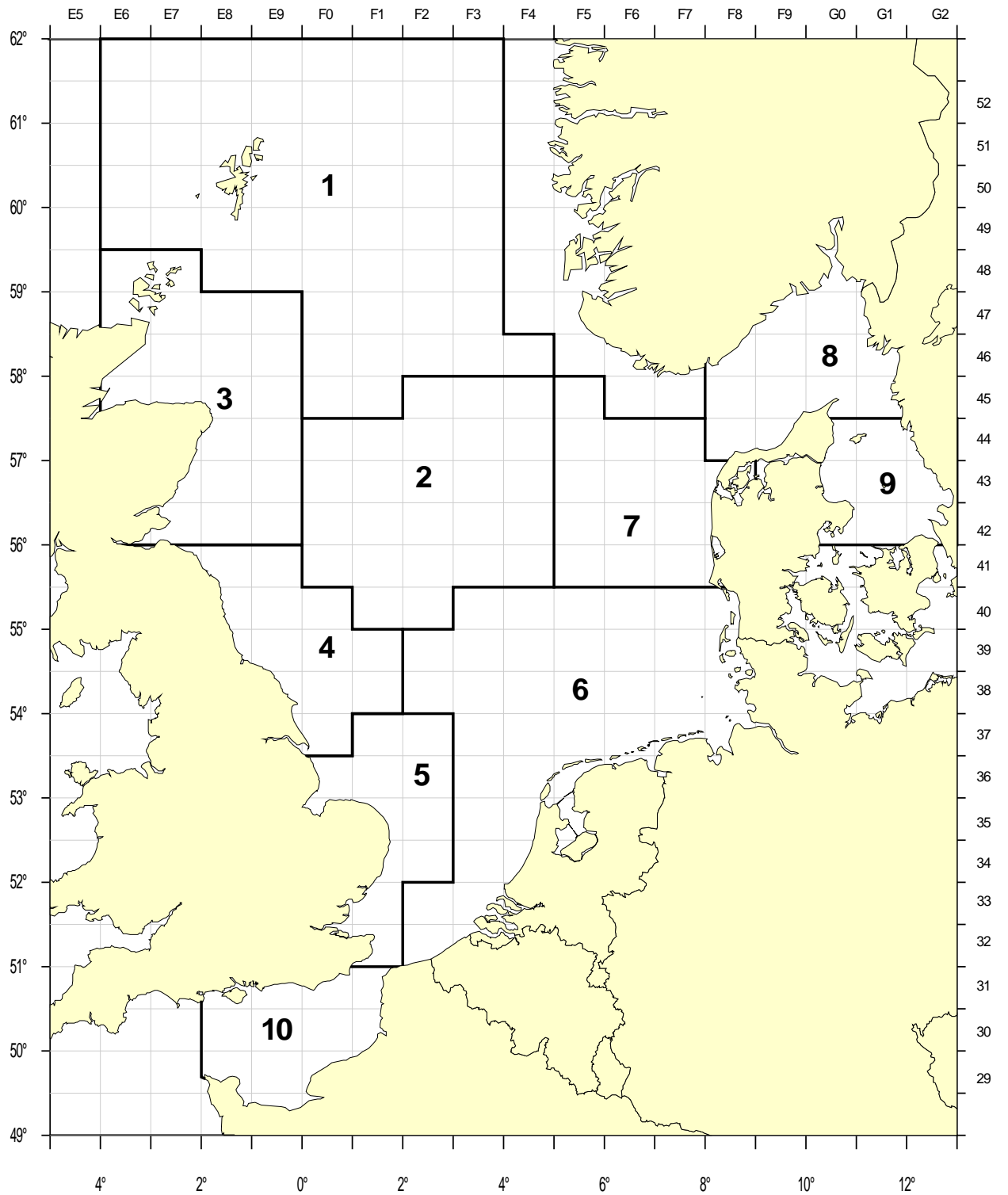

**Figure 6.2. Standard Roundfish Areas: used for roundfish since 1980, for all standard species since 1991. Additional RFA 10 added in 2009.**

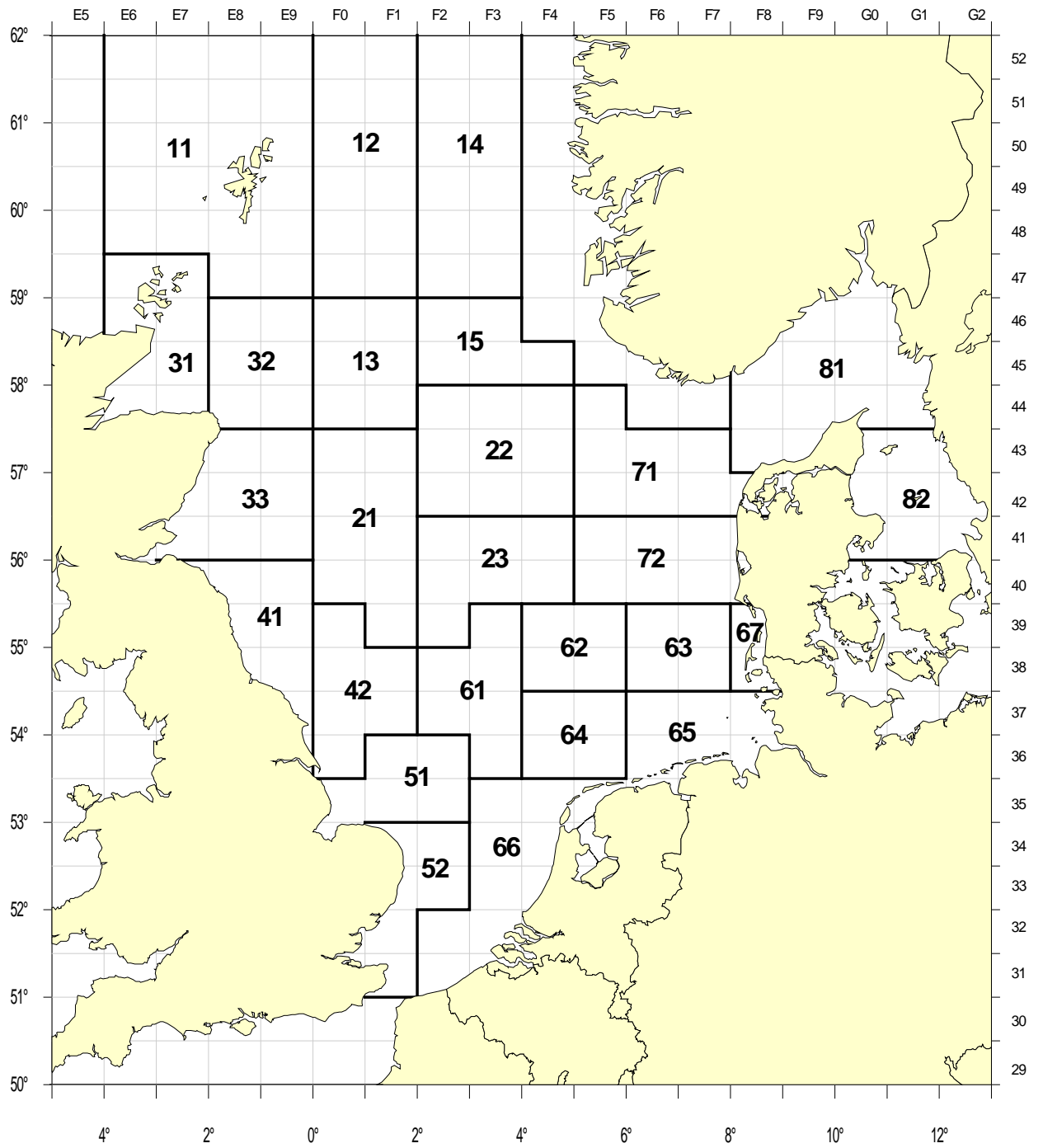

Figure 6.3. Herring Sampling Areas: used in the period 1983–1990.

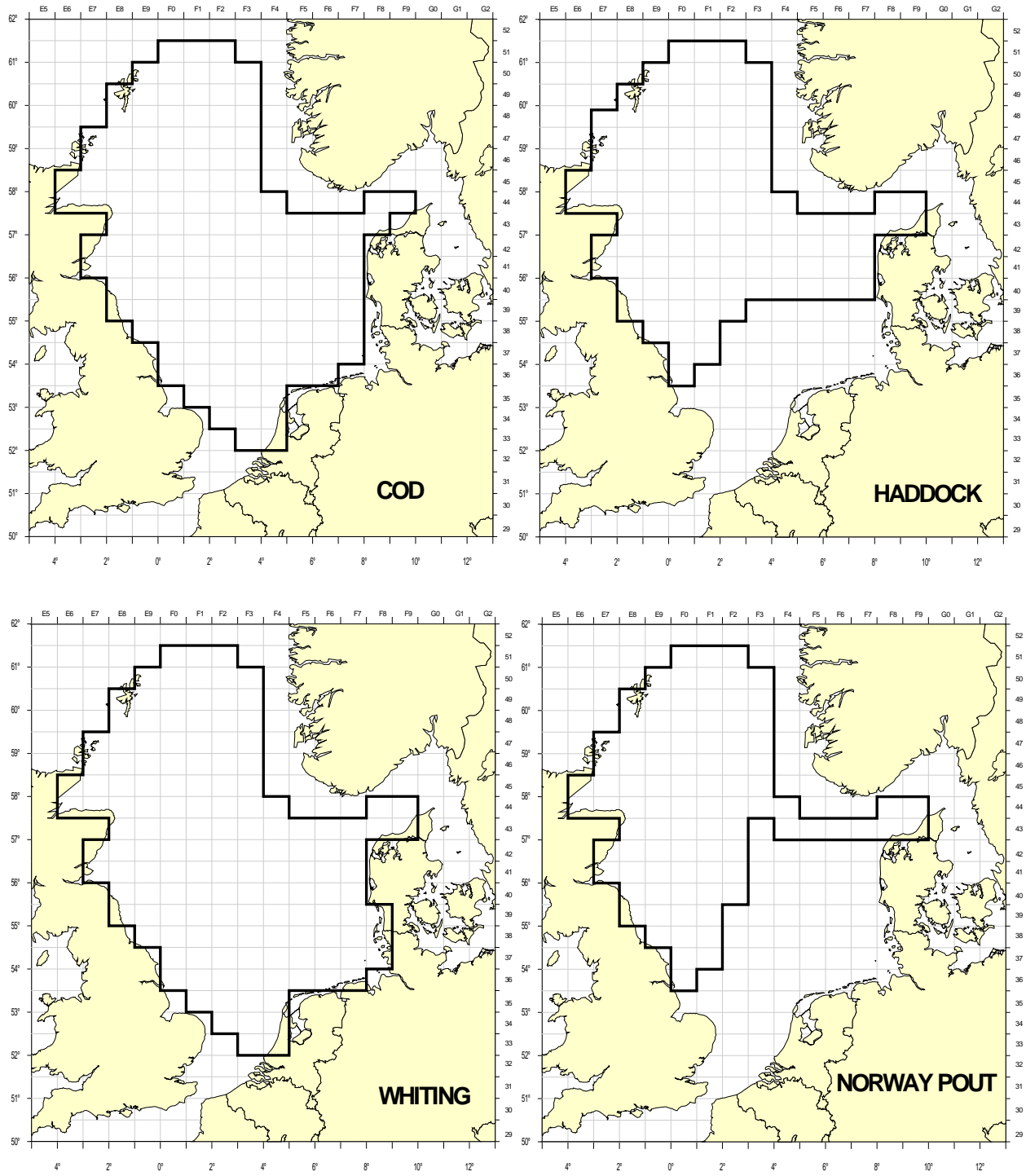

Figure 6.4. Standard areas for the calculation of the IBTS abundance indices. Information obtained from DATRAS database at ICES.

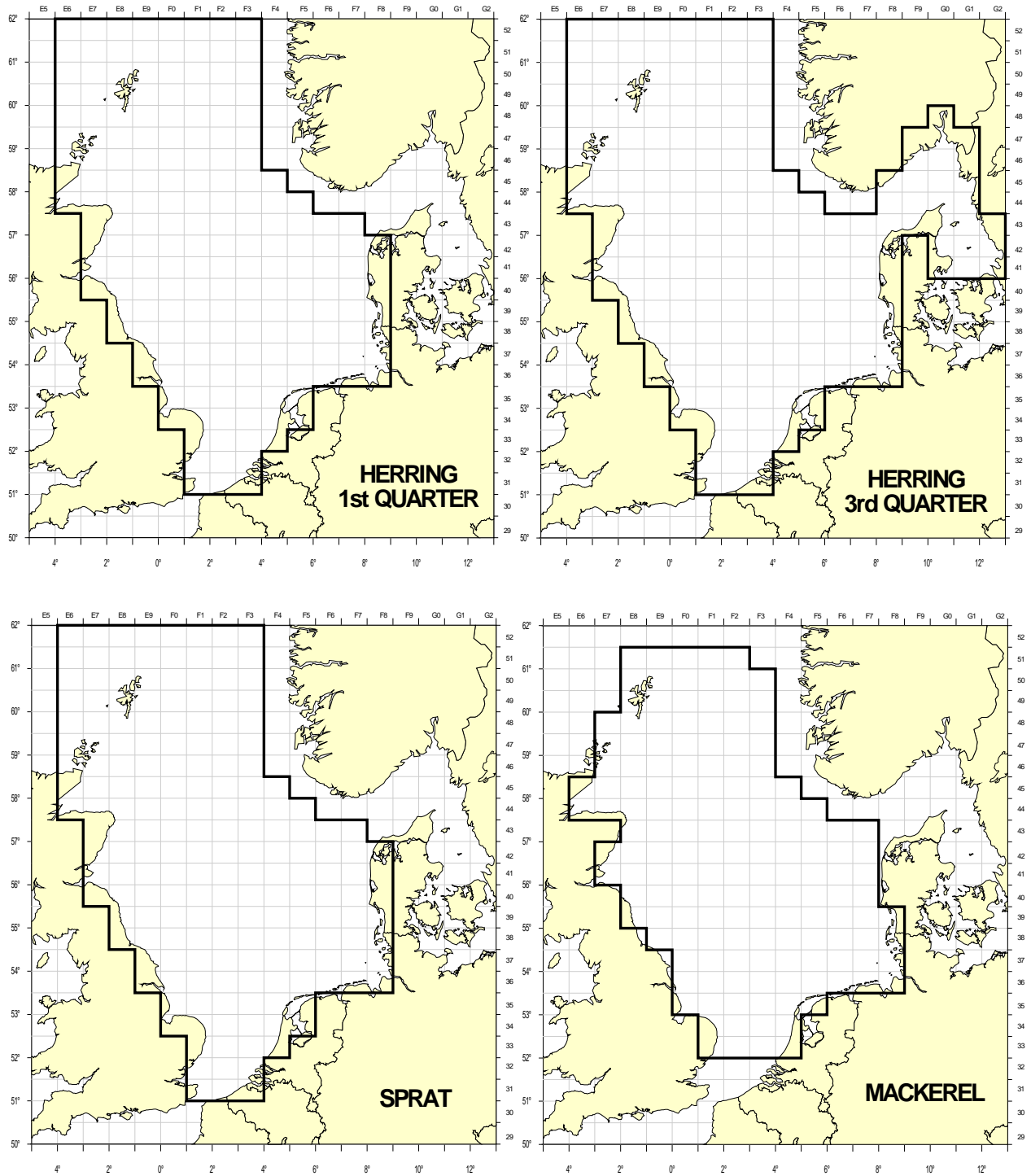

Figure 6.4 Continued.

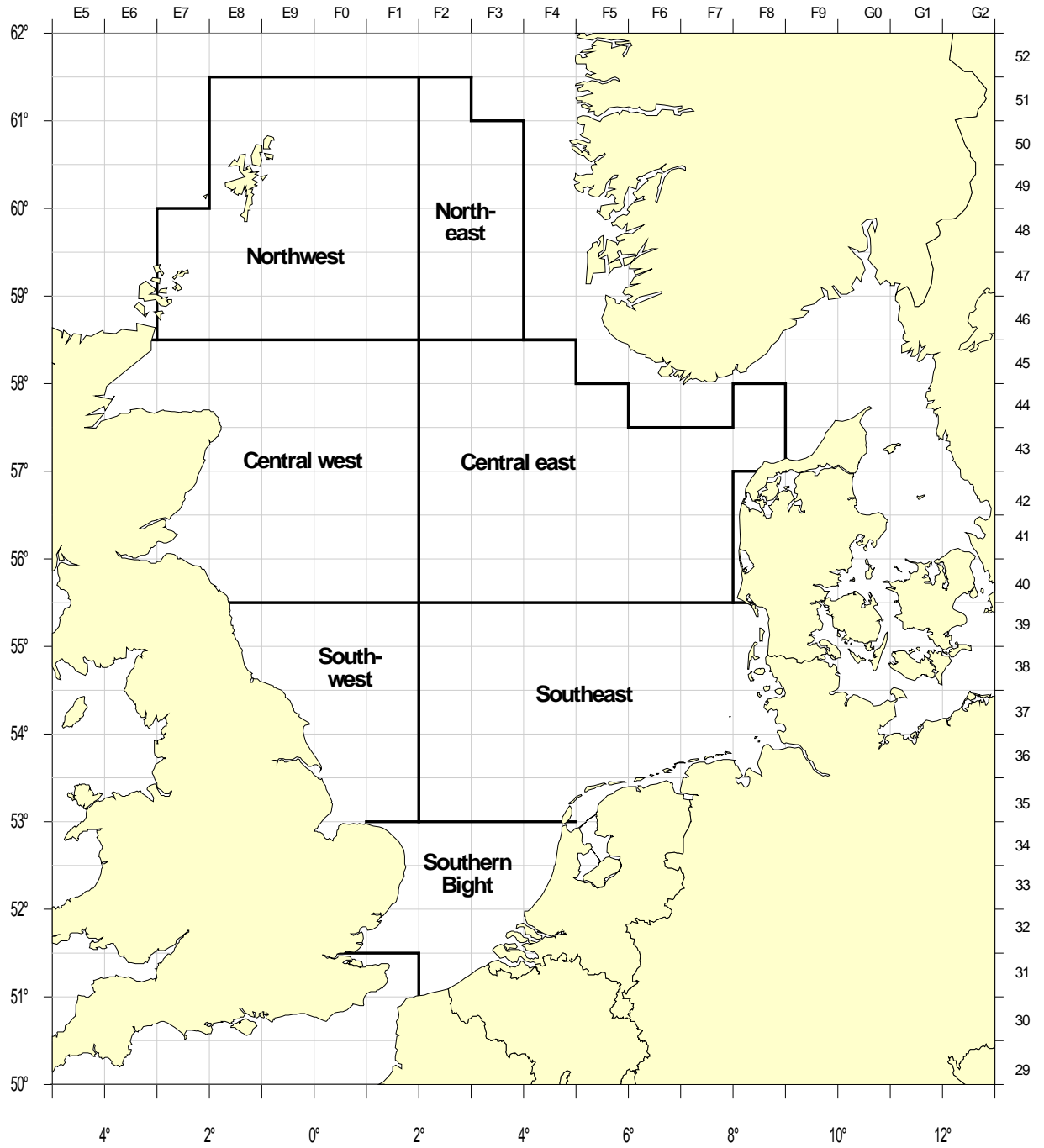

Figure 6.5. Subareas used for the calculation of abundance indices of herring larvae.

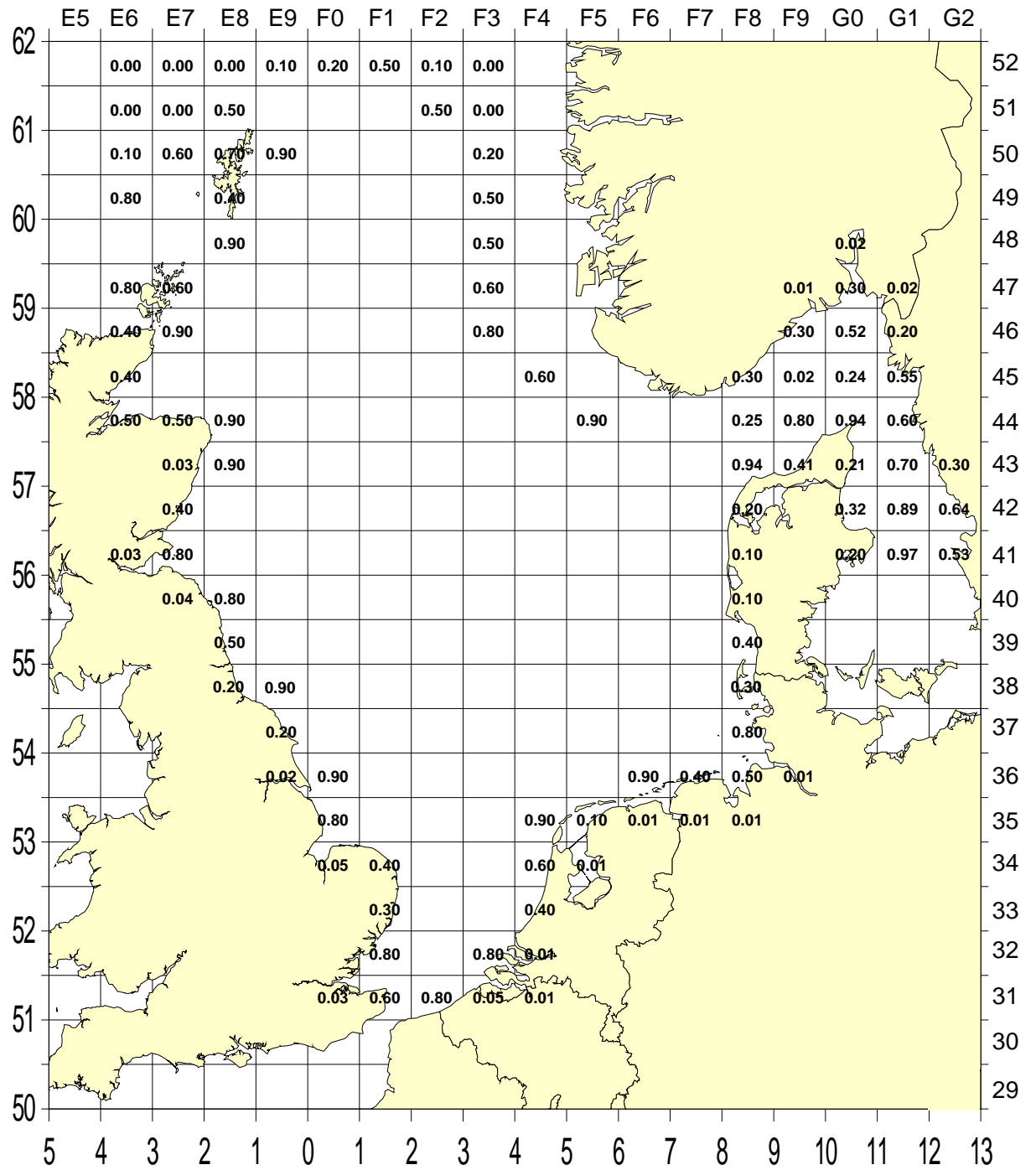

Figure 6.6. Rectangles with weightings used for calculation of the abundance indices of herring larvae.

## Appendix Ia: Chronology of the International Bottom Trawl Survey

1960-1961	Spring and autumn trawl surveys to map distribution of herring
1966	Annual surveys in the southern and central North Sea established to obtain recruitment indices for the combined North Sea herring stocks - the International Young Herring Survey (IYHS).
1969	Skagerrak and Kattegat included in survey area
1970s	Many different survey trawls being used by various institutes carrying out different surveys in the North Sea, Skagerrak and Kattegat, among them the Dutch Herring Trawl, GOV and Herring Trawl
1974	Northern North Sea included in survey area to collect data for gadoids
1975	Recommendation for participants in IYHS to use Isaacs-Kidd midwater trawl to fish for herring larvae at night
1976	Some participants start to fish ½ hour tows in order to reduce gear damage and increase numbers of hauls per day
1977	IYHS Working Group and Gadoid I-Group Working Group recommend that all participants change to ½ hour tow duration. Working Groups also recommend that from 1978 the GOV trawl be the standard gear for future surveys. At least 4 countries were to use this gear in 1978, with other participants changing over to the GOV at the earliest possible occasion
1981	Survey was renamed the International Young Fish Survey (IYFS)
1983	All Quarter 1 participants use standard GOV.
1984	ICES 'Working Group on Young Herring Surveys' and the 'Gadoid I-Group Working Group' were combined to form the International Young Fish Survey (IYFS) Working Group.
1990	IYFS WG proposed to combine the IYFS and other national surveys into Quarterly Coordinated Surveys in the North Sea, Skagerrak and Kattegat, which were to be called the International Bottom Trawl Surveys (IBTS).
1991-1996	Quarterly surveys undertaken
1992	All participating countries now using GOV as standard survey gear for all quarters.
1997	National financial constraints reduce coordinated surveys to quarter 1 and quarter 3 with target coverage of 2 hauls per ICES rectangle per survey.
2001	Western Areas IBTS surveys first coordinated manual produced.
2005	New revision to North Sea Survey Manual – Revision VII

---

2008	France extend Q1 survey area into the Eastern English Channel
2009	Norway unable to participate in Q3 IBTS. Eastern English Channel area cover by France recognized as new Roundfish Area (RFA) 10.
2010	New revision of North Sea Survey Manual – Revision VIII.

---



### Appendix Ib: History of the North Sea IBTS Surveys

YEAR(S)	FREQUENCY	REGION	GROUND GEAR	PELAGIC GEAR (LARVAE)	TOW DURATION	SURVEY NAME	ICES WG	REFERENCE
From	to				[min]			
1960	1961	twice annually						ICES (1963) - ICES 1963. International Young Herring Surveys. Report of Working Group meeting in IJmuiden, 26-27 March, 1963. ICES CM 1963/Herring Committee:101
1965	1968	annually	Southern/ central North Sea		60	International Young Herring Survey	WG on Young Herring Surveys	
1969		annually	Southern/ central North Sea, Skagerrak, Kattegat		60			
1974		annually	Entire North Sea, Skagerrak, Kattegat	various	60			
1975		annually		MIK as standard for larvae	60			
1976		annually			30 (some) / 60			
1977		annually		GOV recommended as standard	30 (all except one country) / 60			ICES (1977) - Report of the Working Group on North Sea Young Herring Surveys. ICES CM 1977/H:11
Year(s)	Frequency	Region	Ground gear	Pelagic gear (larvae)	Tow duration	Survey name	ICES WG	Reference
From	to				[min]			
1978		annually	GOV used by 4 vessels		30 (all except one country) / 60			

YEAR(S)	FREQUENCY	REGION	GROUND GEAR	PELAGIC GEAR (LARVAE)	TOW DURATION	SURVEY NAME	ICES WG	REFERENCE
1981	annually				30 (all except one country) / 60	International Young Fish Survey (IYFS)	WG on Young Herring Surveys; Gadoid 1-Group WG	
1983	current		GOV used by all nations		30 (all except one country) / 60			
1984	annually				30 (all except one country) / 60		IYFS WG	
1991	1996	quarterly			30 (all except one country) / 60	International Bottom Trawl Survey (IBTS)		ICES CM 1990/H:3, ICES CM 1996/H:01
1997	1998	twice annually			30 (all except one country) / 60			Heessen, H.J.L., J. Dalskov and R.M. Cook (1997). The International Bottom Trawl Survey in the North Sea, the Skagerrak and Kattegat. ICES CM 1997/Y:31
1999	current	Twice annually			30			



**Appendix III: IBTS Standard Gear Check sheet 2**

**GOV 36/47 GROUND FISH SURVEY TRAWL CHECKLIST**  
 Check Sheet 2: Frame ropes daigram

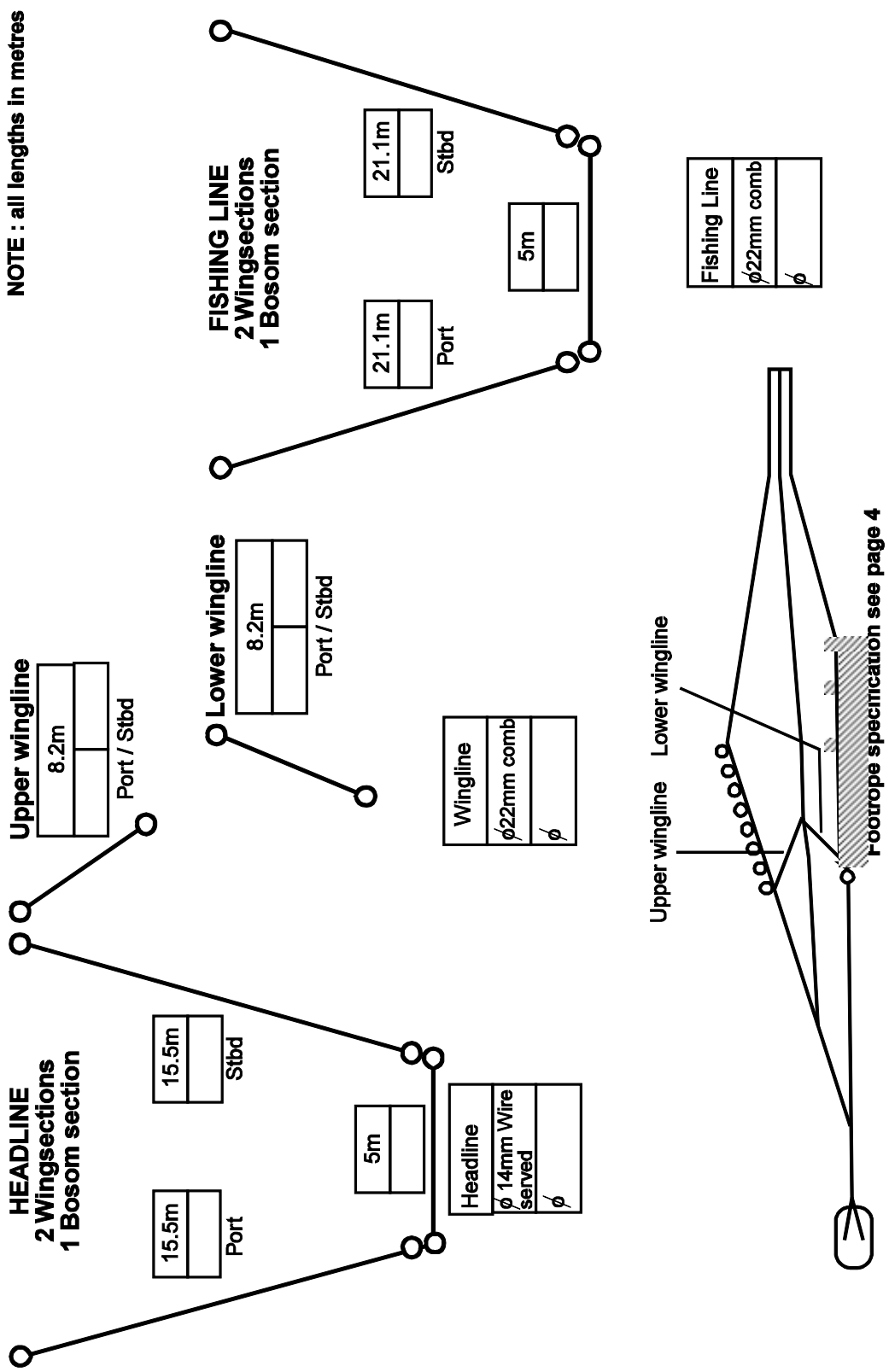

**Appendix IV: IBTS Standard Gear Check sheet 3**

**GOV 36/47 GROUND FISH SURVEY TRAWL CHECKLIST**  
 Check sheet 3: Overall rigging diagram

Vessel	
Cruise	
Date	
Checked by	
Checked by	
Measured to nearest cm below	

Ribline longer than netting (length for length)	YES	
	NO	

Floats Buoyancy

60 x 200mmAL	172 Kg
--------------	--------

Upper Bridle

φ14mm x 20m	
-------------	--

U/m Bridle Extn.

φ14mm x 20m	
-------------	--

Otterboard

Oval Poly	
-----------	--

4.5m SQM

Port / Stbd	
-------------	--

Kilte

6.7m

5.5m

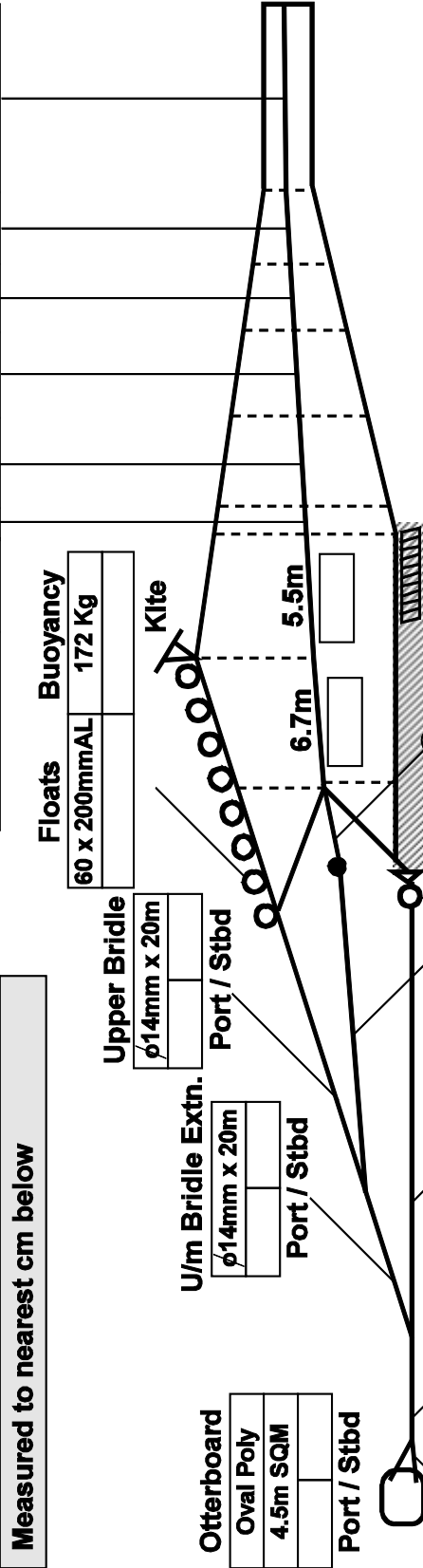

Sweep	φ22mm	Port / Stbd
Upper / Lower		
Backstop		
Port		
Stbd		
Backstop Extn.		
Port		
Stbd		

Lower Bridle	φ20mm x 38m	Port / Stbd
--------------	-------------	-------------

Sweep length + Backstop length + Backstop extension length (if used) should total 60m overall.

Middle Bridle	φ14mm x 20m	Port / Stbd
---------------	-------------	-------------

M. Bridle Extn.	φ14mm x 7.1m	Port / Stbd
-----------------	--------------	-------------

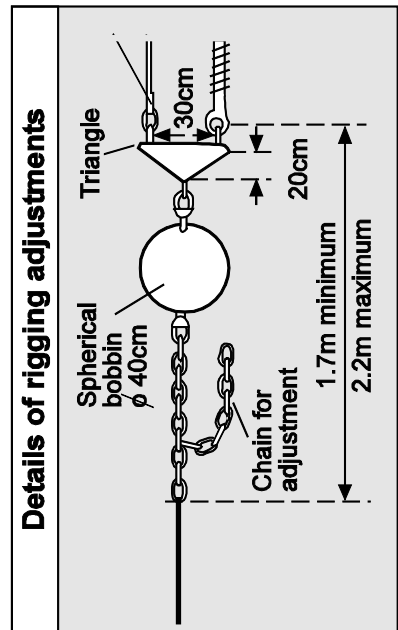

**Appendix Va: IBTS Standard Gear Check sheet 4 – Ground Gear A**

**GOV 36/47 GROUND FISH SURVEY TRAWL CHECKLIST**

Check sheet 4 : Ground gear rigging  
(Maximum length of link between sections is 10cm)

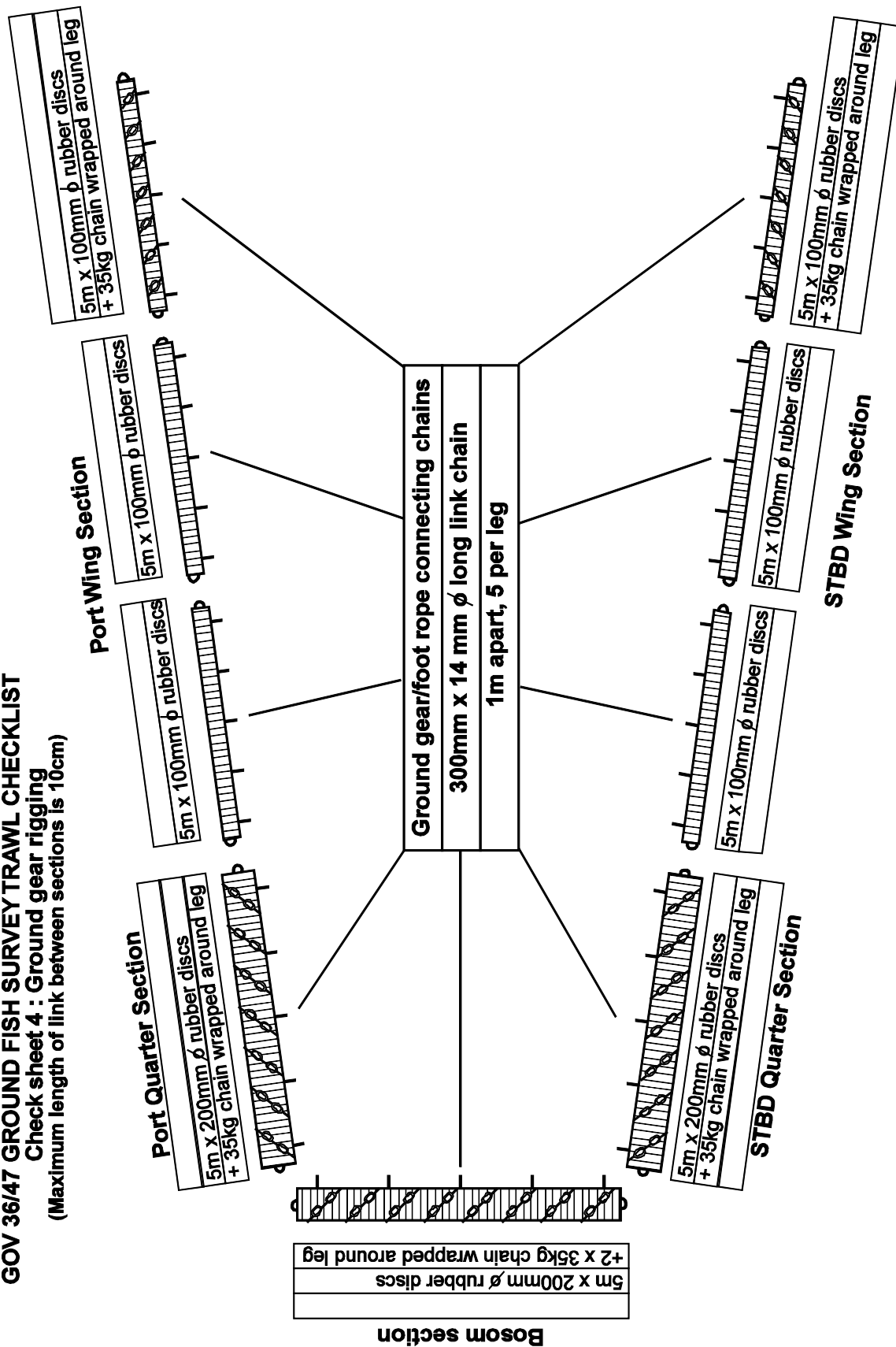

## Appendix Vb: IBTS Standard Gear Check sheet 4 – Ground Gear B

### GOV 37/47 GROUND FISH SURVEY TRAWL CHECKLIST

#### Check sheet 4 : Ground gear rigging

(Maximum length of link between sections is 10cm)

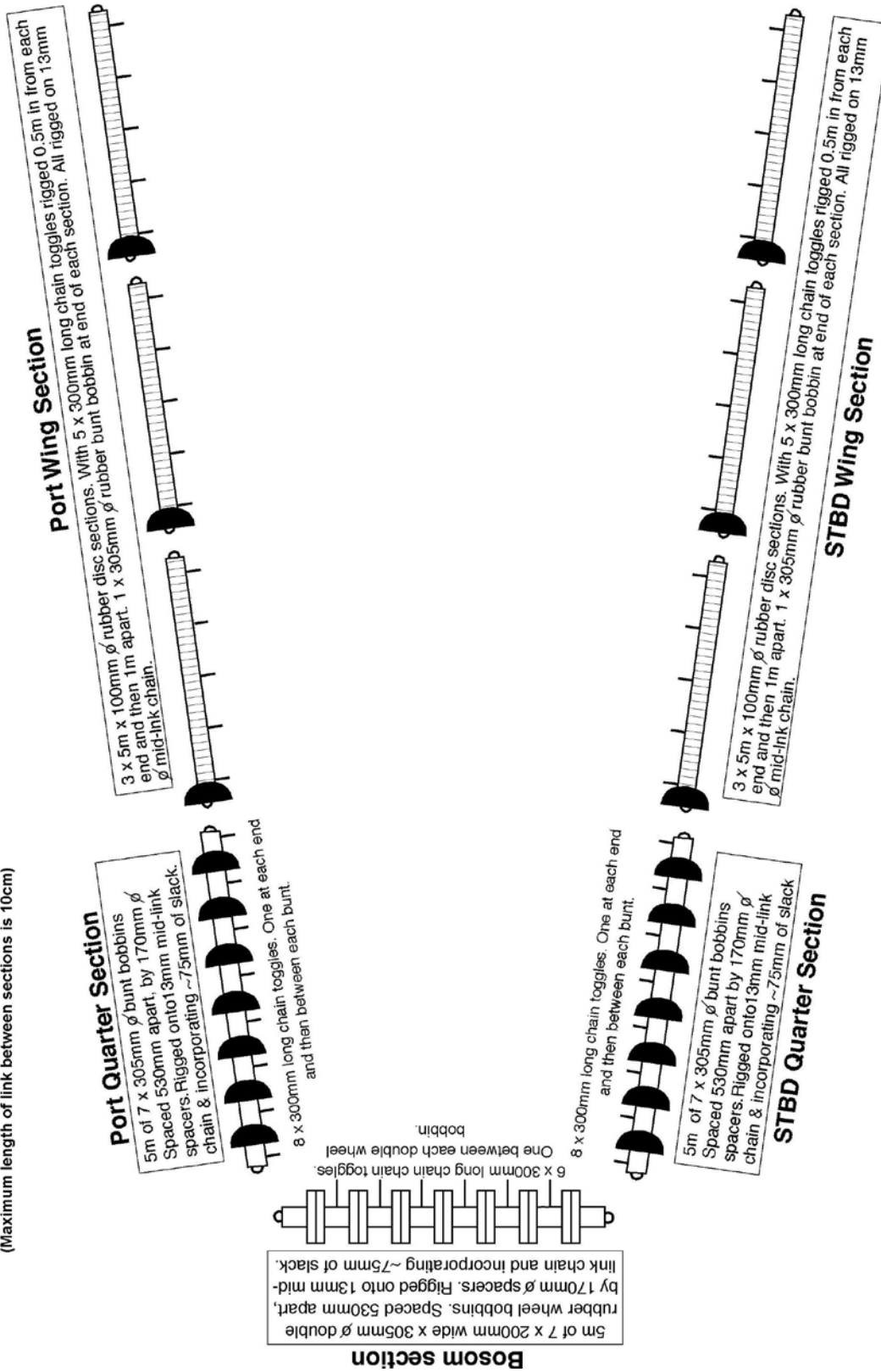

Notes : Each 5m long section includes the length of a hammerlock connector.

### Appendix VI: Catch sampling summary for North Sea IBTS quarter 1 surveys

North Sea quarter 1

		Denmark	France	Germany	Netherlands	Norway	Sweden	UK(Eng)	UK(Scot)
<b>Staffing</b>	number available for catch processing	4	8/10	6/8	4	2/3	6/7	6/7	6
<b>Hauls</b>	Average number per day	3/4	4	4	4/5	3/4	5	3/4	4/5
<b>Catch</b>	retention in hopper or bin	y	y	y	y	y	y	y	y
	codend cleaned	y	y	y	y	y		y	y
	net cleaned	y	y	n	n	y		y	y
	cleanings added to catch	y	y	p	p	y		y	y
<b>Sorting</b>	'deckmaster' in charge	y	y	y	y	y	y	y	y
	sorting facility - bench or conveyor	c	c	c	c	b	c	b	b
	complete sort upto no. bstkts	30	20	40	40	10	3	40	50
	small fish mixture sub sorting	y	y	y	y	y	y	y	y
	part of the catch discarded unprocessed	n	n	n	n	y		n	n
<b>Categories</b>	by sex (1)	n	y	y	y	n	y	y	y
	by size large or small	y	y	y	y	y		y	y
	by size multi modal	y	n	n	y	y	y	y	n
<b>Sub sample</b>	re-mix before selection	y	y	y	y	n	n	y	n
	selection random	y	y	y	y	y	y	y	y
<b>Weighing</b>	all catch components	y	y	y	n	y	y	y	y
	all sub samples	y	y	y	n	y	y	y	y
<b>Measuring</b>	all fish species (2)	y	y	y	y	n	y	y	y
	minimum sample size	75	100	100	50	50	50	75	150
	commercial benthos	n	c	n	c	n	y	y	n
	cephalopods	n	c	n	c	y	y	n	n
	other benthos - weigh, count, observe	n	c	o	c	n	o	o	n
<b>Biological sampling</b>	prescribed species (3)	y	y	y	y	y	y	y	y
	other species (4)	n	n	n	y	n	y	y	y
	weight	y	n	y	y	y	y	y	y
	sex	y	y	y	y	y	y	y	y
	maturity	y	y	y	y	y	y	y	y
	age material	y	y	y	y	y	y	y	y
	ageing - at sea or ashore	a	s/a	a	a	a	a	a	s
	<b>Data capture</b>	station detail - electronic or paper/pencil	e/p	e	e	p	e/p	p	p
catch detail - electronic or paper/pencil		p	e	p	e	e	p	e	p
length detail - electronic or paper/pencil		p	p	p	e	e	p	e	p
biological detail - electronic or paper/pencil		p	p	p	p	e	p	e	p
error checking		y	y	y	y	y	y	y	y
back up		y	y	y	y	y	y	y	y

		Denmark	France	Germany	Netherlands	Norway	Sweden	UK(Eng)	UK(Scot)
<b>(1) Categories by sex</b>	plaice	n	y	n	n	n		y	n
	dab	n	n	y	n	n		y	n
	elasmobranchs	n	y	n	y	n		y	y
<b>(2) Measuring 0.5cm</b>	herring	y	y	y	y	y		y	y
	sprat	y	y	y	y	y		y	y
	pilchard	y	y	y	n	n		y	n
	anchovie	y	y	y	n	n		y	n
<b>(2) Measuring mm</b>	commercial benthos	n	y	n	n	n		y	n
<b>(3) Prescribed species</b>	cod	y	y	y	y	y	y	y	y
	haddock	y	y	y	y	y	y	y	y
	whiting	y	y	y	y	y		y	y
	saithe	y	y	y	y	y		y	y
	Norway pout	y	y	y	y	y	y	y	y
	herring	y	y	y	y	y	y	y	y
	sprat	y	y	y	y	n	y	y	y
	mackerel	y	y	y	y	p		y	y
	plaice	n	y	y	n	n	y	y	n
	<b>(4) Other species</b>	dab	n	n	n	n	n		y
brill		n	n	n	n	n		y	n
turbot		n	n	n	n	n		y	n
lemon sole		n	n	n	n	n		y	n
anglers		n	n	n	n	n		y	y
elasmobranchs		n	n	n	y	n		y	n



### Appendix VII: Catch sampling summary for North Sea IBTS quarter 3 surveys

#### North Sea quarter 3

		Denmark	Germany	Norway	Sweden	UK(Eng)	UK(Scot)
<b>Staffing</b>	number available for catch processing	5	6/8	2/3	4/5	6/7	6
<b>Hauls</b>	Average number per day	3/4	4	7/8	5	3/4	4/5
<b>Catch</b>	retention in hopper or bin	y	y	y	y	y	y
	codend cleaned	y	y	y		y	y
	net cleaned	y	n	y		y	y
	cleanings added to catch	y	p	y		y	y
<b>Sorting</b>	'deckmaster' in charge	y	y	y	y	y	y
	sorting facility - bench or conveyor	c	c	b	c	b	b
	complete sort upto no. bstkts	30	40	10	3	40	50
	small fish mixture sub sorting	y	y	y	y	y	y
	part of the catch discarded unprocessed	n	n	y		n	n
<b>Categories</b>	by sex (1)	n	y	n	y	y	y
	by size large or small	y	y	y		y	y
	by size multi modal	y	n	y	y	y	n
<b>Sub sample</b>	re-mix before selection	y	y	n		y	n
	selection random	y	y	y	y	y	y
<b>Weighing</b>	all catch components	y	y	y	y	y	y
	all sub samples	y	y	y	y	y	y
<b>Measuring</b>	all fish species (2)	y	y	n	y	y	y
	minimum sample size	75	100	50	50	75	150
	commercial benthos	n	n	n	y	y	n
	cephalopods	n	n	y	y	n	y
	other benthos - weigh, count, observe	n	o	n	o	o	n
<b>Biological sampling</b>	prescribed species (3)	y	y	y	y	y	y
	other species (4)	n	n	n	y	y	y
	weight	y	y	y	y	y	y
	sex	y	y	y	y	y	y
	maturity	y	y	y	y	y	y
	age material	y	y	y	y	y	y
	ageing - at sea or ashore	a	a	a	a	a	s
<b>Data capture</b>	station detail - electronic or paper/pencil	e/p	e	e/p	p	p	p
	catch detail - electronic or paper/pencil	p	p	e	p	e	p
	length detail - electronic or paper/pencil	p	p	e	p	e	p
	biological detail - electronic or paper/pencil	p	p	e	p	e	p
	error checking	y	y	y	y	y	y
	back up	y	y	y	y	y	y

		Denmark	Germany	Norway	Sweden	UK(Eng)	UK(Scot)
<b>(1) Categories by sex</b>	plaice	n	n	n		y	n
	dab	n	y	n		y	n
	elasmobranchs	n	n	n		y	y
<b>(2) Measuring 0.5cm</b>	herring	y	y	y		y	y
	sprat	y	y	y		y	y
	pilchard	y	y	n		y	n
	anchovie	y	y	n		y	n
<b>(2) Measuring mm</b>	commercial benthos	n	n	n		y	n
<b>(3) Prescribed species</b>	cod	y	y	y	y	y	y
	haddock	y	y	y	y	y	y
	whiting	y	y	y		y	y
	saithe	y	y	y		y	y
	Norway pout	y	y	y	y	y	y
	herring	y	y	y	y	y	y
	sprat	y	y	n	y	y	y
	mackerel	y	y	y		y	y
	plaice	n	y	n	y	y	n
	<b>(4) Other species</b>	dab	n	n	n		y
brill		n	n	n		y	n
turbot		n	n	n		y	n
lemon sole		n	n	n		y	n
anglers		n	n	n		y	y
elasmobranchs		n	n	n		y	n

**Appendix VIII: Finfish Maturity Key**

---

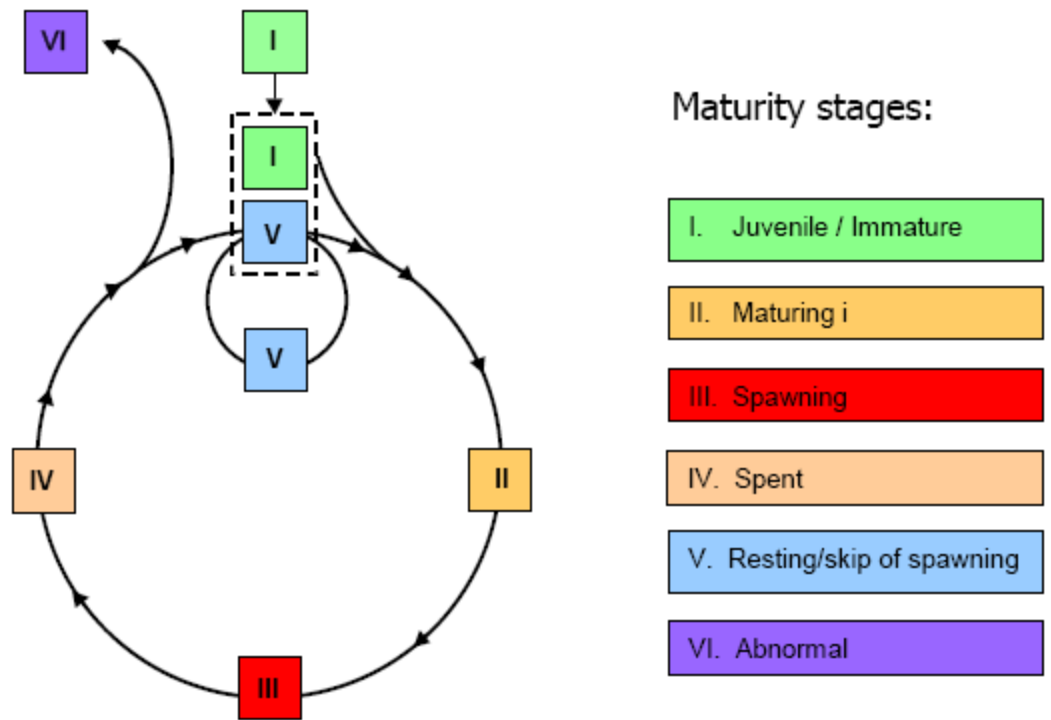

Vector diagram showing the maturity cycle for finfish species using the new 6 stage maturity key.

## Female maturity key stage descriptors for gadoid species

STAGE	DESCRIPTION OF APPEARANCE OVARIES	HISTOLOGY
1	Juvenile/Immature	
	No sex determination: juvenile below 15 cm, risk of mistaking gonads for bladder.	Oogonia / PN
	Sex determination: Juvenile-transparent ovaries.	PN
	Immature-translucent ovaries, coloration is pinkish to light orange, cast thin and clear. Blood vessels hardly discernable.	PN/CNR
2	Maturing: Firm, coloration ranges from reddish orange to creamy orange with granulated/oocytes clearly visible in issue. Blood vessels larger and diversified.	CA/T
3	Spawning: Distended, few to many hydrated eggs visible in tissue among vitelogenic oocytes or in lumen, occasionally running.	FM/HYD/POF
4	Spent: Slack with greyish cast, rich in blood vessels.	POF, perhaps atretia, PN, CNR
5	Resting/Skip of spawning*: No visible development-similar to Immature but sometimes with a greyish cast.	PN, CNR, perhaps atresia
6	Abnormal*: Hard parts (connective tissue), only one lobe developed, intersex, or similar-fecundity at least partly reduced.	Variable

Ecosystem state indicators\*

## Male maturity key stage descriptors for gadoid species

STAGE	DESCRIPTION	HISTOLOGY
I	Juvenile/Immature.	
	No sex determination: juvenile below 15 cm, gonads difficult to identify.	Germ cells/SG
	Sex determination: Juvenile-transparent testes.	Germ cells/SG
	Immature-testes with developing frills, coloration is reddish to white, vascularisation is limited.	SG/SC1
II	Maturing: Whitish to almost opaque reddish-white, blood vessels more prominent, empty transparent spermatoducts.	SC1/SC2/ST, spermatids/non-motile flagellate SZ
III	Spawning: Opaque creamy white colour to reddish late in stage, semen visible in spermatoduct, milt often flows at ligh pressure.	Aligned ripe SZ proximally and in sperm duct, cyst, no lobule walls.
IV	Spent: Contracted, empty and flabby lobules, colour deep pink to reddish-purple, bloodshot, potentially with greyish cast.	Migrating germ cells/SG, interlobular walls thickens, atretic spermatozoa
V	Resting/Skip of spawning*: No visible development, spermatoducts often with a greyish cast, similar to immature, early maturing.	Migrating germ cells/SG, resting cysts of SG and SC1.
VI	Abnormal*: Adipose tissue, only one lobe developed, intersex, or similar.	Variable

Ecosystem state indicators\*

### Appendix IX: Four Stage Maturity Key for Skates and Rays (*Rajidae*)

STAGE	MALE	FEMALE
A	Immature: Claspers undeveloped, shorter than extreme tips of posterior margin of pelvic fin. Testes small and thread-shaped.	Immature: Ovaries small, gelatinous or granulated, but with no differentiated oocytes visible. Oviducts small and thread-shaped, width of shell gland not much greater than the width of the oviduct.
B	Maturing: Claspers longer than posterior margin of pelvic fin, their tips more structured, but the claspers are soft and flexible and the cartilaginous elements are not hardened. Testes enlarged, sperm ducts beginning to meander.	Maturing: Ovaries enlarged and with more transparent walls. Oocytes differentiated in various small sizes (<5mm). Oviducts small and thread-shaped, width of the shell gland greater than the width of the oviduct, but not hardened.
C	Mature: Claspers longer than posterior margin of pelvic fin, cartilaginous elements hardened and claspers stiff. Testes enlarged, sperm ducts meandering and tightly filled with sperm.	Mature: Ovaries large with enlarged oocytes (>5mm), with some very large, yolk-filled oocytes (ca. 10mm) also present. Uteri enlarged and wide, shell gland fully formed and hard.
D	Active: Claspers reddish and swollen, sperm present in clasper groove, or flows if pressure exerted on cloaca.	Active: Egg capsules beginning to form in shell gland and partially visible in uteri, or egg capsules fully formed and hardened and in oviducts/uteri.

## Appendix X: Haul Information

---

Explanations of the various field names and data types can be found on the ICES web page: <http://www.ices.dk/datacentre/datsu/selrep.asp>

### Record Type HH

Start/Order	Field Name	Width	Mandatory	Data Type
1	RecordType	2	✓	char
2	Quarter	1	✓	int
3	Country	3	✓	char
4	Ship	4	✓	char
5	Gear	6	✓	char
6	SweepLngt	3	⊙	int
7	GearExp	2	⊙	char
8	DoorType	2	⊙	char
9	StNo	6	✓	char
10	HaulNo	3	✓	int
11	Year	4	✓	char
12	Month	2	✓	int
13	Day	2	✓	int
14	TimeShot	4	✓	char
15	Stratum	4	⊙	char
16	HaulDur	3	✓	int
17	DayNight	2	✓	char
18	ShootLat	8	✓	decimal
19	ShootLong	9	✓	decimal
20	HaulLat	8	✓	decimal
21	HaulLong	9	✓	decimal
22	StatRec	4	⊙	char
23	Depth	4	✓	int
24	HaulVal	1	✓	char
25	HydroStNo	8	✓	char
26	StdSpecRecCode	1	✓	char
27	BycSpecRecCode	1	✓	char
28	Data Type	2	✓	char
29	Netopening	4	⊙	decimal
30	Rigging	2	⊙	char
31	Tickler	2	⊙	int

## Record Type HH

Start/Order	Field Name	Width	Mandatory	Data Type
32	Distance	4	☉	int
33	WarpIngt	4	☉	int
34	Warpdia	2	☉	int
35	WarpDen	2	☉	int
36	DoorSurface	4	☉	decimal
37	DoorWgt	4	☉	int
38	DoorSpread	3	☉	int
39	WingSpread	2	☉	int
40	Buoyancy	4	☉	int
41	KiteDim	3	☉	decimal
42	WgtGroundRope	4	☉	int
43	TowDir	3	☉	int
44	GroundSpeed	3	☉	decimal
45	SpeedWater	3	☉	decimal
46	SurCurDir	3	☉	int
47	SurCurSpeed	4	☉	decimal
48	BotCurDir	3	☉	int
49	BotCurSpeed	4	☉	decimal
50	WindDir	3	☉	int
51	WindSpeed	3	☉	int
52	SwellDir	3	☉	int
53	SwellHeight	4	☉	decimal
54	SurTemp	4	☉	decimal
55	BotTemp	4	☉	decimal
56	SurSal	5	☉	decimal
57	BotSal	5	☉	decimal
58	ThermoCline	2	☉	char
59	ThClineDepth	4	☉	int

## Appendix XI: Length Frequency Information

---

Record Type HL

Start/Order	Field Name	Width	Mandatory	Data Type
1	RecordType	2	✓	char
2	Quarter	1	✓	int
3	Country	3	✓	char
4	Ship	4	✓	char
5	Gear	6	✓	char
6	SweepLngt	3	⊙	int
7	GearExp	2	⊙	char
8	DoorType	2	⊙	char
9	StNo	6	✓	char
10	HaulNo	3	✓	int
11	Year	4	✓	char
12	SpecCodeType	1	✓	char
13	SpecCode	10	✓	char
14	SpecVal	2	✓	char
15	Sex	2	⊙	char
16	TotalNo	9	⊙	decimal
17	CatIdentifier	2	✓	int
18	NoMeas	3	✓	int
19	SubFactor	9	✓	decimal
20	SubWgt	6	⊙	int
21	CatCatchWgt	8	✓	int
22	LngtCode	2	✓	char
23	LngtClass	4	✓	decimal
24	HLNoAtLngt	6	✓	decimal

## Appendix XII: SMALK

---

**N.B.** When sending information on herring in 1<sup>st</sup> Quarter, number of rings should be substituted for age.

### Record Type CA

Start/Order	Field Name	Width	Mandatory	Data Type
1	RecordType	2	✓	char
2	Quarter	1	✓	int
3	Country	3	✓	char
4	Ship	4	✓	char
5	Gear	6	✓	char
6	SweepLngt	3	⊙	int
7	GearExp	2	⊙	char
8	DoorType	2	⊙	char
9	StNo	6	✓	char
10	HaulNo	3	✓	int
11	Year	4	✓	char
12	SpecCodeType	1	✓	char
13	SpecCode	10	✓	char
14	AreaType	2	✓	char
15	AreaCode	4	✓	char
16	LngtCode	2	✓	char
17	LngtClass	4	✓	decimal
18	Sex	2	✓	char
19	Maturity	2	✓	char
20	PlusGr	2	✓	char
21	AgeRings	2	✓	int
22	CANoAtLngt	3	✓	int
23	IndWgt	5	⊙	decimal



### Appendix XIII: Area Type Codes: Sampling Areas and Standard Areas for the Calculation of Abundance Indices

#### AREA TYPE CODES

0	=	ICES Statistical Rectangles	See CM 1977/Gen:3.
1	=	Four Statistical Rectangles	See Figure 6.1
2	=	Standard Roundfish Areas	See Figure 6.2
3	=	Herring Sampling Areas	See Figure 6.3

**NB:** There has been confusion in the definition of herring areas in the past and for some years no ALK's may have been collected for areas 14, 15 and 67, in which case these areas must be considered as subsets of 12, 13 and 63 respectively. The Skagerrak/ Kattegat areas have also not always been distinguished in which case the appropriate code should be 80. See Figure 6.3.

### Appendix XIV: Length Splits Used to Provide Preliminary Numbers at-age

AGE QUARTER	0-GROUP			1-GROUP			
	2	3	4	1	2	3	4
Cod	11	18	23	25	33	38	44
Haddock	12	17	20	20	27	30	32
Whiting	9	17	20	20	23	24	26
Norway pout	-	13	14	15	15	16	20
Herring	-	15.5	17.5	20.0	21.0	23.0	24.5
Sprat	-	-	10.0	10.0	10.5	13.0	14.0
Mackerel	-	17	24	25	25	30	31
Saithe	-	22	25	25	25	33	38
Plaice	-	10	12	-	-	19	21

**NB:** The lengths indicated are 'less than' lengths: 0-group cod in quarter 2 are fish <11 cm.